

Dimensions: mm (in.)

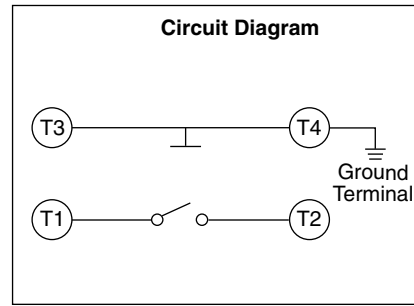
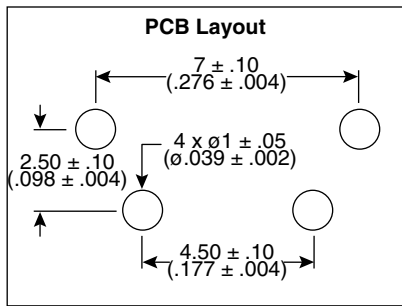
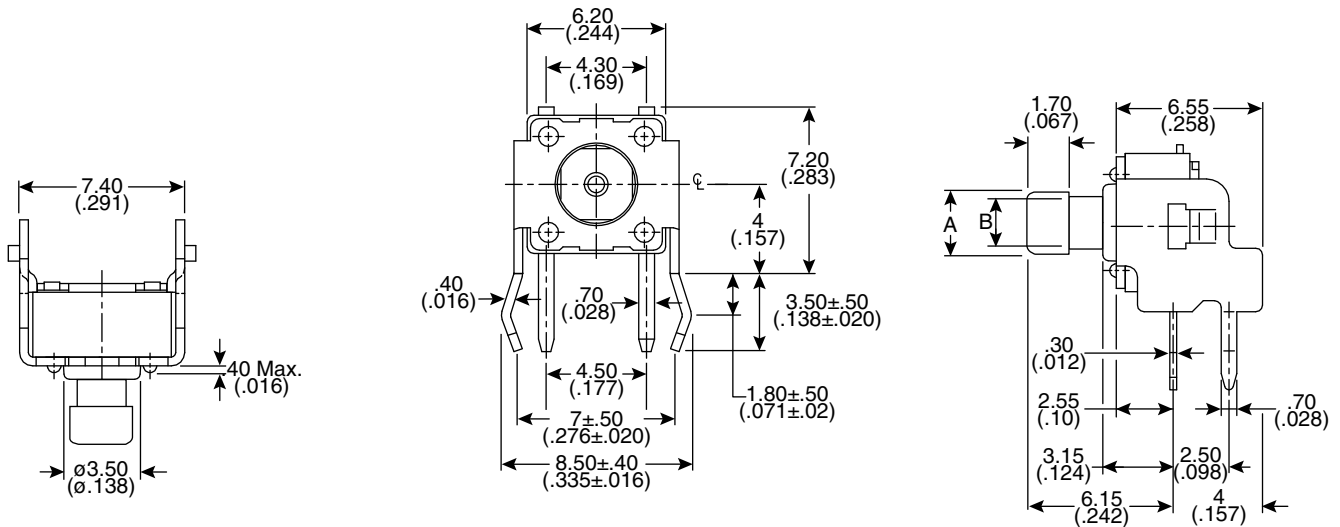

Mechanical Specifications:

- Type: SPST
- Operation Force: 160 ± 50gf Brown (N)
- Stop Strength: Max. 3kgf vertical static load continuously for 15 seconds
- Stroke: (6x6) 0.25 +0.2mm/-0.1mm
- Operating Temperature: -25°C to +70°C
- Storage Temperature: -30°C to +80°C

Electrical Specifications:

- Electrical Life: 1,000,000 cycles
- Rating: 50mA/12VDC
- Contact Resistance: 100mΩ max.
- Insulation Resistance: 100MΩ min. @100VDC
- Dielectric Strength: 25VAC/1 min.

Materials:

- Cover: Steel, tin plated
- Base: UL 94V-0 Nylon Thermoplastic
Color: Black
- Contact disc: Phosphor bronze w/ silver cladding
- Terminal: Brass w/ silver plating
- Cap: Thermoplastic ABS

Note:

- RoHS Compliant and Process compatible with 260° solder.

Mouser Stock No.	A mm(in.)	B mm(in.)
101-TS6511R1604BC-EV	2.4 (.095)	1.6 (.063)
101-TS6511R1605BC-EV	2.8 (.11)	2.0 (.079)

Tactile Switches

101-TS6511R1605BC-EV, 101-TS6511R1604BC-EV



Available from Mouser Electronics

www.mouser.com

1-800-346-6873

Specifications are subject to change without notice. No liability or warranty implied by this information. Environmental compliance based on producer documentation.