

Dimensions: mm (In)

Circuit Diagram

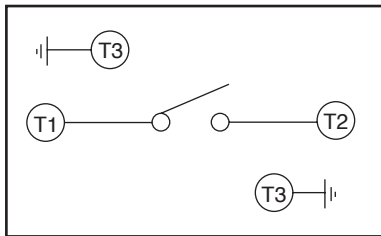

PCB Layout

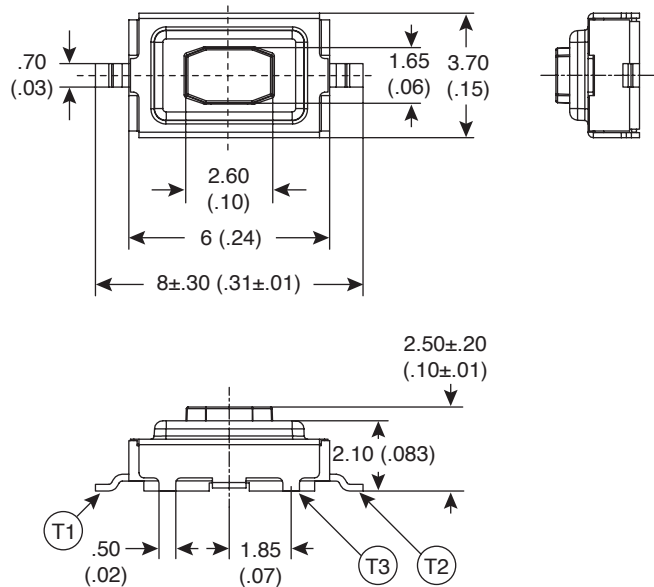
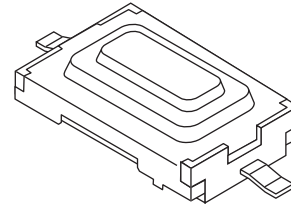
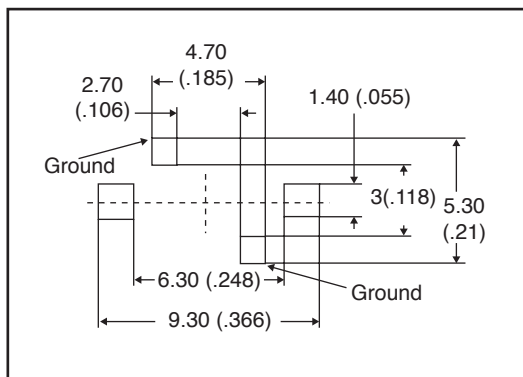

Electrical Specifications:

- Electrical: 50,000 cycles for 160gf
- Rating: 50mA/12VDC
- Contact Resistance: 100mΩ max.
- Insulation Resistance: 100MΩ min., at 500VDC
- Dielectric Strength: 250 VAC / 1 minute

Note:

- RoHS Compliant and process compatible with 260° solder

Mechanical Specifications:

- Operation Force: 160±50gf Brown (N)
- Stroke: 0.25+0.2/-0.1mm
- Operating Temperature Range: -25°C to +70°C
- Storage Temperature Range: -30°C to +80°C
- Contact Arrangement: 1 pole 1 throw

Materials:

- Cover: Nickel silver
- Contact Disc: Stainless with silver cladding
- Terminal: Brass with silver cladding
- Base: UL94V-0 Nylon high temp thermoplastic, black
- Stem: UL94V-0 Nylon high temp thermoplastic, black
- Adhesions Tape: Teflon

Tactile Switch
101-TS3724T1600-EV



Available from Mouser Electronics

www.mouser.com

1-800-346-6873