

Dimensions: mm (in.)

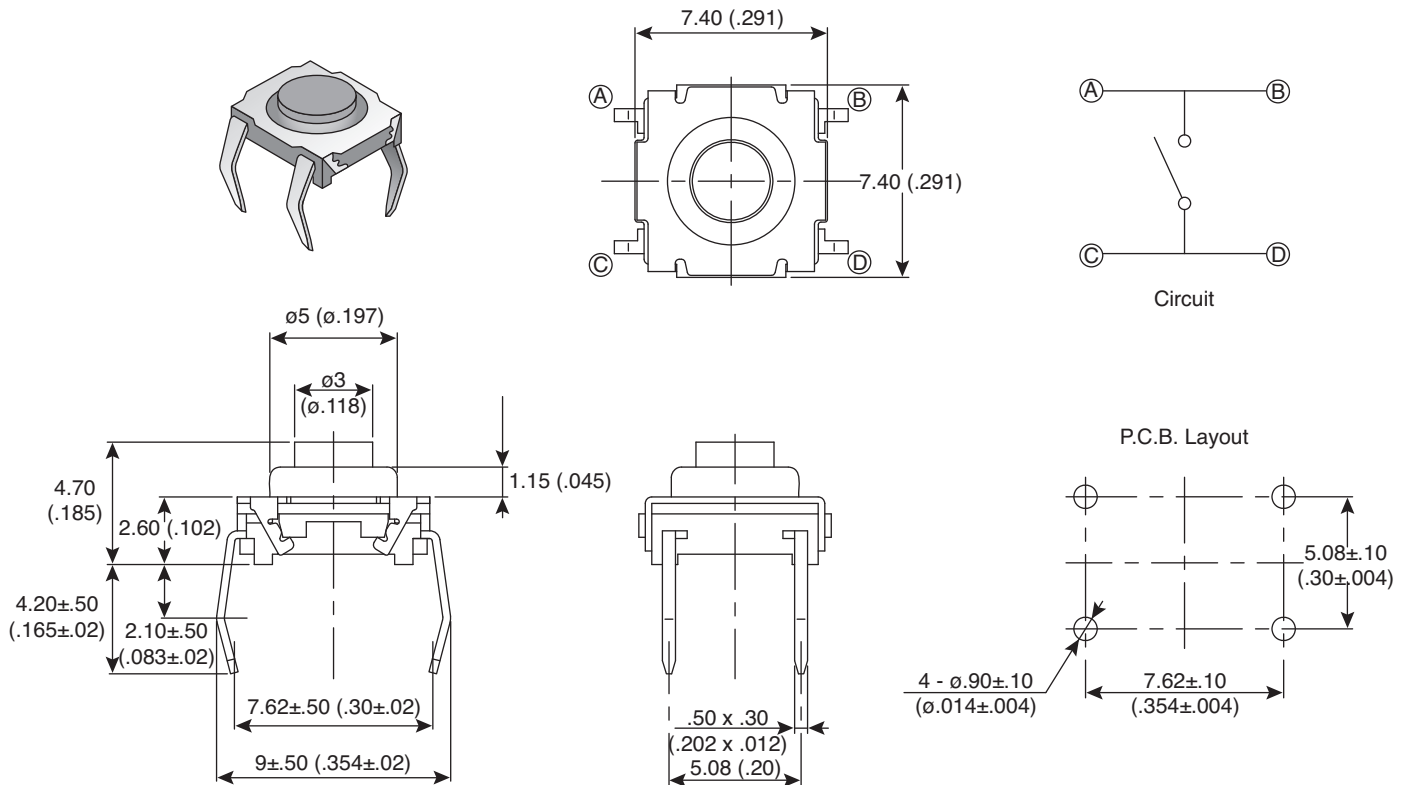

**Electrical Specifications:**

- Rating: 50mA/50 VDC
- Contact Resistance: 100m $\Omega$  max.
- Insulation Resistance: 100 VDC 1,000M $\Omega$  min.
- Dielectric Strength: 250 V AC(50Hz or 60Hz) for 1 minute

**Mechanical Specifications:**

- Operating Temperature: -40° C to +90° C
- Storage Temperature: -40° C to +90° C
- Operating Force: 101-TH71-EV= 130gf, 101-TH72-EV= 300gf
- Operating Force: 130  $\pm$  50g
- Stroke: .50  $\pm$  .20 mm

**Note:**

- RoHS Compliant

**Tactile Switches**

101-TH71-EV, 101-TH72-EV

