

Dimensions: mm (in.)

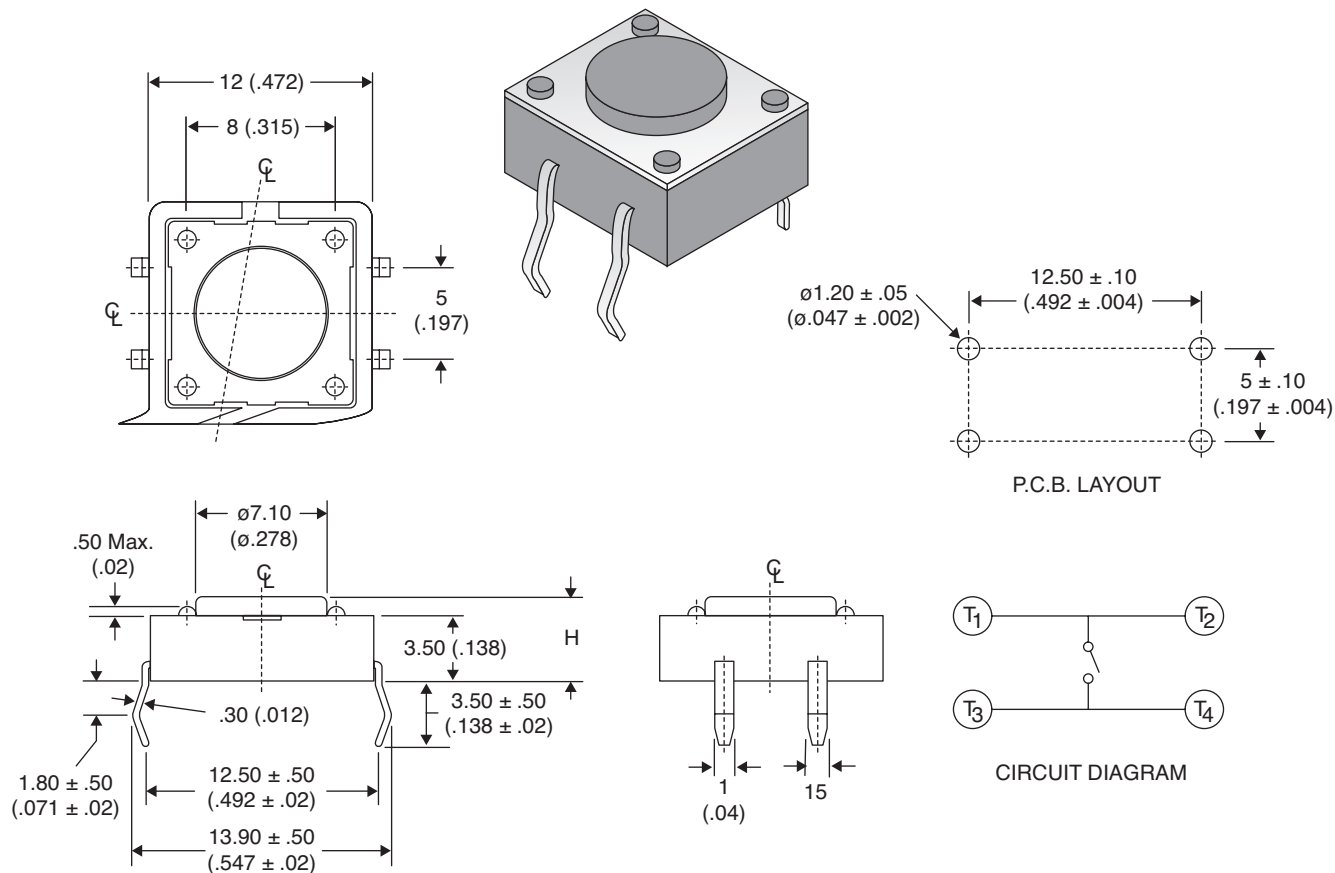

**Electrical Specifications:**

- Rating: 50mA / 12VDC
- Contact Resistance: 100mΩ Max.
- Insulation Resistance: 100MΩ Min.
- Dielectric Strength: 250VAC for 1 Minute

**Mechanical Specifications:**

- Operating Life: 50,000 Cycles
- Operating Temperature: -25°C to +70°C

**Note:**

- RoHS Compliant and Process Compatible with 260° solder

Mountain Switch Part No.	Operating Force	Button Height H (mm)
101-TS6211T2601-EV	260gf	4.3
101-TS6211T3201-EV	320gf	4.3
101-TS6211T1603-EV	160gf	8.5
101-TS6211T2603-EV	260gf	8.5
101-TS6211T3203-EV	320gf	8.5

**Tactile Switches**

101-TS6211T2601-EV, 101-TS6211T3201-EV,  
 101-TS6211T1603-EV, 101-TS6211T2603-EV,  
 101-TS6211T3203-EV

