

Dimensions: mm (In)

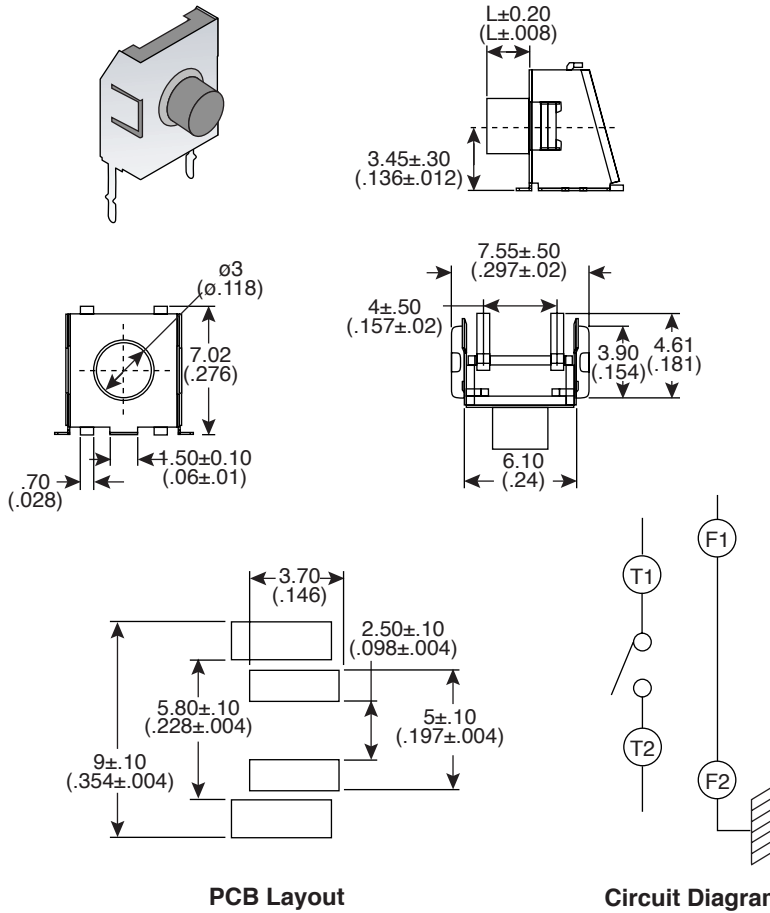

Electrical Specifications:

- Electrical Life: 500,000 cycles for 260gf, 180gf
- Rating: 50mA/12VDC
- Contact Resistance: 100mΩ max.
- Insulation Resistance: 100MΩ min., at 500VDC
- Dielectric Strength: 25 VAC /minute

Mechanical Specifications:

- Stop Strength: Max. 3kgf vertical static load continuously for 15 seconds.
- Stroke: 0.45+0.2mm
- Operating Temperature: -25°C to +70°C
- Storage Temperature: -30°C to +80°C
- Type: SPST
- Operating Force: 180±50gf      260±70gf

Materials:

- Cover: Nickel stainless
- Stem: Silicone rubber (Red/Brown)
- Terminal: Brass with silver cladding
- Color: Black
- Contact: Phosphor bronze with silver cladding

101-TS5722R1801-EV	101-TS5722R2601-EV
101-TS5722R1802-EV	101-TS5722R2602-EV
101-TS5722R1803-EV	101-TS5722R2603-EV
101-TS5722R1804-EV	101-TS5722R2604-EV

Mouser Stock No.	L (mm)	L (IN)
101-TS5722R1801-EV	0.00	0.0000
101-TS5722R2601-EV	0.00	0.0000
101-TS5722R1802-EV	0.80	0.0314
101-TS5722R2602-EV	0.80	0.0314
101-TS5722R1803-EV	1.00	0.0393
101-TS5722R2603-EV	1.00	0.0393
101-TS5722R1804-EV	2.35	0.0925
101-TS5722R2604-EV	2.35	0.0925

Note:

- RoHS compliant and process compatible with 260° solder

Tactile Switches (SMT)

101-TS5722R1801-EV, 101-TS5722R1802-EV, 101-TS5722R1803-EV, 101-TS5722R1804-EV, 101-TS5722R2601-EV, 101-TS5722R2602-EV, 101-TS5722R2603-EV, 101-TS5722R2604-EV

