

Slide Switch 1.4(H)mm, 1.5/2mm-travel Surface Mount Type

SSSS8 Series



A low-profile slide switch with 1.4mm thickness.

- Detector
- Push
- Slide
- Rotary
- Encoders
- Power
- Dual-in-line
Package Type
- TACT Switch™
- Custom-
Products
- Small size
General Use type
- Big size
General Use type
- Other Use type

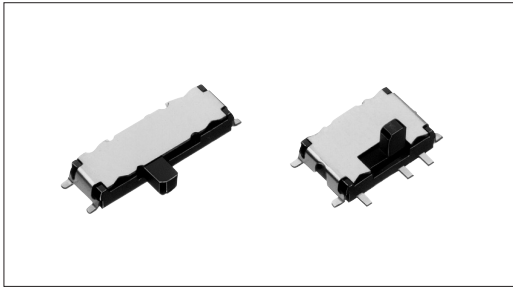

Typical Specifications

Items		Specifications
Rating (max.) / (min.) (Resistive load)		0.3A 5V DC/50μA 3V DC
Contact resistance (Initial performance/After lifetime)		70mΩ max./130mΩ max.
Operating force		Refer to the dimensions.
Operating life	Without load	10,000cycles
	With load	10,000cycles (0.3A 5V DC)

Product Line

Travel (mm)	Actuator direction	Actuator thickness (mm)	Poles	Positions	Changeover timing	Ground terminal	Soldering	Minimum order unit (pcs.)	Products No.	Drawing No.	
1.5	Vertical	t0.8	2	2	Not specified	Without	Reflow	7,200	SSSS820101	1	
				3					SSSS820301	2	
				2					SSSS820201	1	
				3					SSSS820501	2	
	Horizontal	t1.1	1	2		Without		18,000	Without	SSSS810701	3
				3						SSSS811501	4
				2		With			SSSS811101	3	
				3					SSSS812201	4	
2				2				SSSS810201	5		

Packing Specifications

Taping

Unit:mm

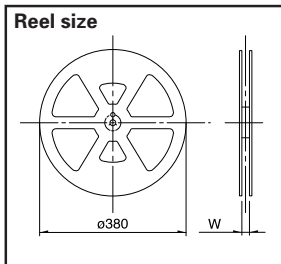

Product No.	Number of packages (pcs.)			Reel width W (mm)	Tape width (mm)	Export package measurements (mm)
	1 reel	1 case /Japan	1 case /export packing			
SSSS820101,SSSS820301, SSSS820201,SSSS820501	1,800	3,600	7,200	25.4	24	406 × 406 × 190
SSSS810701,SSSS811501, SSSS811101,SSSS812201, SSSS810201	4,500	9,000	18,000	17.4	16	417 × 409 × 139

Notes

- Products other than those listed in the above chart are also available. Please contact us for details.
- Please place purchase orders per minimum order unit N (integer).

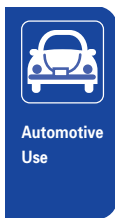

Dimensions

1.5mm-travel

Unit:mm

No.	Photo	Style	PC board mounting hole and land dimensions (Viewed from direction A)
1		<p>Terminal No.① 0.4 3 1.5 0.75 With ground terminal dimensions</p> <p>Operating force : 2N</p>	<p>2-ϕ0.9 holes 3 1.5 0.75 0.7 6-pattern section</p> <p>4-pattern section for ground terminal</p>
2		<p>Terminal No.① 1.5 3 1.5 With ground terminal dimensions</p> <p>Operating force : a \rightarrow b } 2N c \rightarrow b } 2N</p>	<p>2-ϕ0.9 holes 1.5 3 1.5 0.7 8-pattern section</p> <p>4-pattern section for ground terminal</p>
3		<p>Terminal No.① 0.4 3 1.5 With ground terminal dimensions</p> <p>Operating force : 1.5N</p>	<p>2-ϕ0.9 holes 3 1.5 0.75 0.7 3-pattern section</p> <p>4-pattern section for ground terminal</p>
4		<p>Terminal No.① 1.5 3 1.5 With ground terminal dimensions</p> <p>Operating force : a \rightarrow b } 1.5N c \rightarrow b } 1.5N b \rightarrow a } 2N b \rightarrow c } 2N</p>	<p>2-ϕ0.9 holes 1.5 3 1.5 0.7 4-pattern section</p> <p>4-pattern section for ground terminal</p>

Note

Products not marked with ※ in the drawing have no ground terminal.

Detector

Push

Slide

Rotary

Encoders

Power

Dual-in-line
 Package Type

TACT Switch™

Custom-
 Products

Small size
 General Use type

Big size
 General Use type

Other Use type



Automotive
 Use

Dimensions

Horizontal Operating Section Type 2mm-travel

Unit:mm

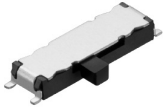
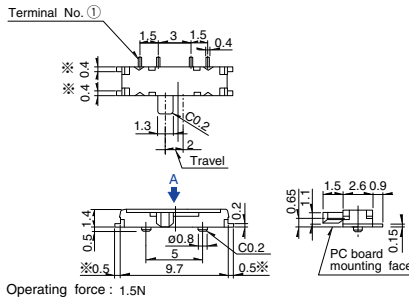
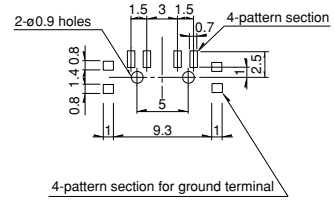
No.	Photo	Style	PC board mounting hole and land dimensions (Viewed from direction A)
5			

Note

Products not marked with ※ in the drawing have no ground terminal.

Circuit Diagram (Viewed from Direction A)

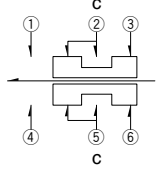
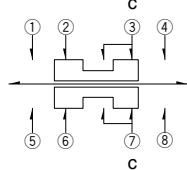
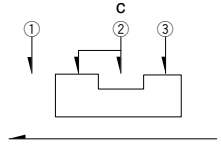
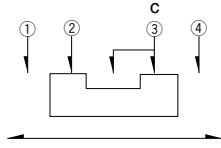
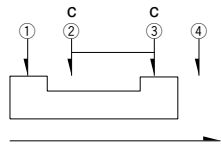
<p>2-poles, 2-positions Drawing No. : 1</p> 	<p>2-poles, 3-positions Drawing No. : 2</p> 	
<p>1-pole, 2-positions 1.5mm-travel Drawing No. : 3</p> 	<p>1-pole, 3-positions 1.5mm-travel Drawing No. : 4</p> 	<p>2-poles, 2-positions Drawing No. : 5</p> 







Small size
General Use type

Big size
General Use type

Other Use type



List of Varieties

Series		SSAL	SSAJ	SSAG	SSAH	SSSS8	SSSS7 ※1	SSSS2	
Photo									
Outline specifications	Travel (mm)	2	1.4	1.5		1.5 2		2	
	Actuator direction	Horizontal				Vertical Horizontal	Horizontal	Vertical Horizontal	
	Number of poles	1				1 2			
Dimensions (mm)	W	7.6	5.5	9.05	9.5	11.2	8.8	13	
	D	2.6	2.5	3		2.6	3	3.5	
	H	1.2	0.7	1.15	0.9	1.4	2		
Operating temperature range		-10°C to +60°C			-30°C to +60°C	-40°C to +85°C			
Automotive use		—	—	—	—	○	—	—	
Rating (max.)/(min.) (Resistive load)		10mA 5V DC			1mA 5V DC	0.3A 5V DC	0.3A 4V DC	0.3A 6V DC	
		50μA 3V DC							
Electrical performance	Initial contact resistance	10Ω max.	300mΩ max.	200mΩ max.		70mΩ max.			
	Insulation resistance	100MΩ min. 100V DC					100MΩ min. 500V DC		
	Voltage proof	100V AC for 1minute					500V AC for 1minute		
Mechanical performance	Terminal strength	3N for 1minute							
	Actuator strength	10N				10N	20N		
Durability	Operating life without load	100,000cycles 10Ω max.	10,000cycles 500mΩ max.	30,000cycles (Lockside) 100,000cycles 500mΩ max. (Recoilside)	10,000cycles 300mΩ max.	10,000cycles 100mΩ max. ※2			
	Operating life without load Load:as rating	10,000cycles 130mΩ max. ※2							
Environmental performance	Cold	-40±2°C for 96h		-20±2°C for 96h		-40°C±2°C for 96h	-20°C±2°C for 96h		
	Dry heat	85±2°C for 96h							
	Damp heat	40±2°C, 90 to 95%RH for 96h							
Soldering	Manual soldering	350±5°C 3s max.				300±5°C 5s max.	300±5°C 3s max.	350±10°C 4s max.	
	Dip soldering	260±5°C 3±1s							
	Reflow soldering	Please see P.175							
Poles-positions	1-2	●	●	—	—	●	●	●	
	1-3	—	—	●	●	●	●	●	
	1-4	—	—	—	—	●	—	●	
	2-2	—	—	—	—	●	—	●	
	2-3	—	—	—	—	●	—	●	
	2-4	—	—	—	—	—	—	●	
	4-2	—	—	—	—	—	—	—	
Page		132	134	136	139	141	144	147	

Detector

Push

Slide

Rotary

Encoders

Power

Dual-in-line
Package Type

TACT Switch™

Custom-
Products

Small size
General Use type

Big size
General Use type

Other Use type

- Slide Switches Soldering Conditions175
- Slide Switches Cautions176

Notes

- ※1. The operating temperature range for automotive applications can be raised upon request. Please contact us for details.
- ※2. Operating life for SSSS213202 is 100 cycles
3. ○marks in "Available for automotive use" indicate that some of the series products can work at the operating temperature range from -40°C to +85°C.

Soldering Conditions

Example of Reflow Soldering Condition

1. Heating method: Double heating method with infrared heater.
2. Temperature measurement: Thermocouple 0.1 to 0.2 ϕ CA (K) or CC (T) at soldering portion (copper foil surface). A heat resisting tape should be used for fixed measurement.
3. Temperature profile

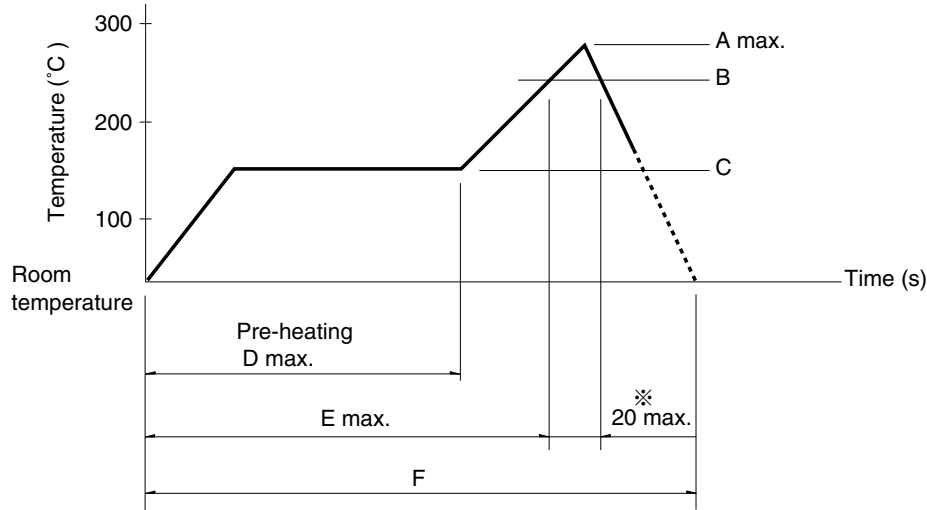

Series (Reflow type)			A (°C) 3s max.	B (°C)	C (°C)	D (s)	E (s)	F (s)
SSSS2	Vertical	1-pole, 3-positions	250	200	150	120	—	—
	Horizontal	1-pole, 2-positions						
	Vertical	1-pole, 2-positions	240					
	Horizontal	1-pole, 3-positions 2-poles, 3-positions						
SSSS7			250					
SSAH, SSAG, SSAJ			260	230				
SSSS8	Horizontal	1-pole, 2-positions 1-pole, 3-positions (1.5mm)	255	200				
	Vertical		240	220				

Notes

1. The condition mentioned above is the temperature on the mounting surface of a PC board. There are cases where the PC board's temperature greatly differs from that of the switch, depending on the PC board's material, size, thickness, etc. The above-stated conditions shall also apply to switch surface temperatures.
2. Soldering conditions differ depending on reflow soldering machines. Prior verification of soldering condition is highly recommended.
3. ※SSAH and SSAG only 40's.

Detector

Push

Slide

Rotary

Encoders

Power

Dual-in-line
Package Type

TACT Switch™

Custom-
Products

Small size
General Use type

Big size
General Use type

Other Use type