

IP67 CKS SEALED ROTARY SWITCH

GENERAL ELECTRICAL & MECHANICAL SPECIFICATION

Switch Rating:	150mA @ 250V ac/dc 1A @ 24V dc
Life:	>10,000 Cycles
Operating Temperature:	-30°C to +85 °C
Proof Voltage:	1,500Vac (Initial)
Insulation Resistance:	>999 MΩ at 500Vdc (Initial)
Contact Resistance:	<20 mΩ (initial)
Operating Torque (nominal)	Standard 10.5 ± 1 N cm Light Action 5.5 ± 0.5 N cm
End Stop Torque (nominal):	0.80 Nm
Moulding Material:	Polyamide 6.6 G.F. V0 RATED
Contact/Terminal Material:	Brass CZ108 Ag Plated

RoHS COMPLIANT



GENERAL FEATURES & OPTIONS

- Made in UK
- Cost effective single wafer switch
- Moulded 27.5mm diameter
- Standard 30° indexing
- Solder or Printed Circuit Board Terminals
- Up to 4 poles per switch
- Maximum 12 positions
- Moulded in UL94 V0 material.
- Optional reinforcement ring.
- Shorting (make before break 30° indexing only) or non shorting (break before make) contacts.
- Special options: 60° or 90° indexing, continuous rotation. Fixed stop, gold flash or gold plated contacts, and spindles with special flats.
- CKS same form, fit & function to the CK range
- Dampened indexing & reduced shaft play gives smooth feel.
- Front panel sealed to IP66 – protected against powerful water jets
- Front panel sealed to IP67 – protected against the effects of temporary immersion in 1 meter of water. (ancillaries required)

CKS ROTARY SWITCH SPECIFICATION SHEET

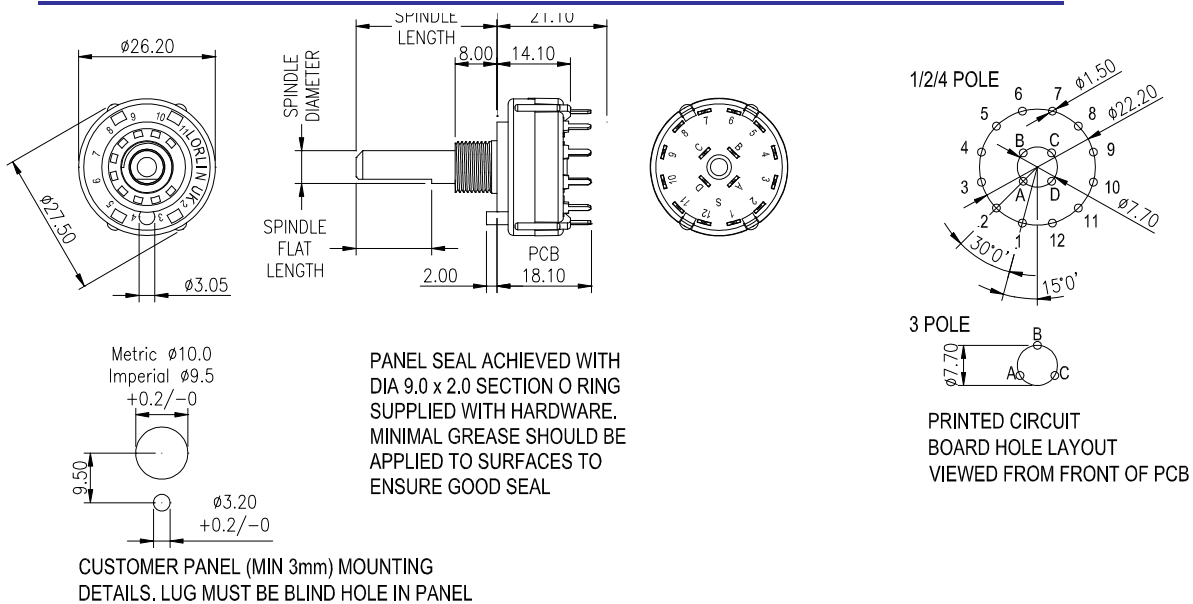

BASIC TYPES	SPINDLE DIAMETER	SPINDLE LENGTH FROM MOUNTING FACE	8mm LONG BUSH	SPINDLE FLAT LENGTH	ANGLE OF SPINDLE FLAT	SPINDLE FLAT THICKNESS
IMPERIAL	6.35mm	38mm	9.52 x 32TPI	30mm	90°	5.5mm
METRIC	6.00mm	50mm	M10 x 0.75	No Flat	---	---

CKS ROTARY SWITCH

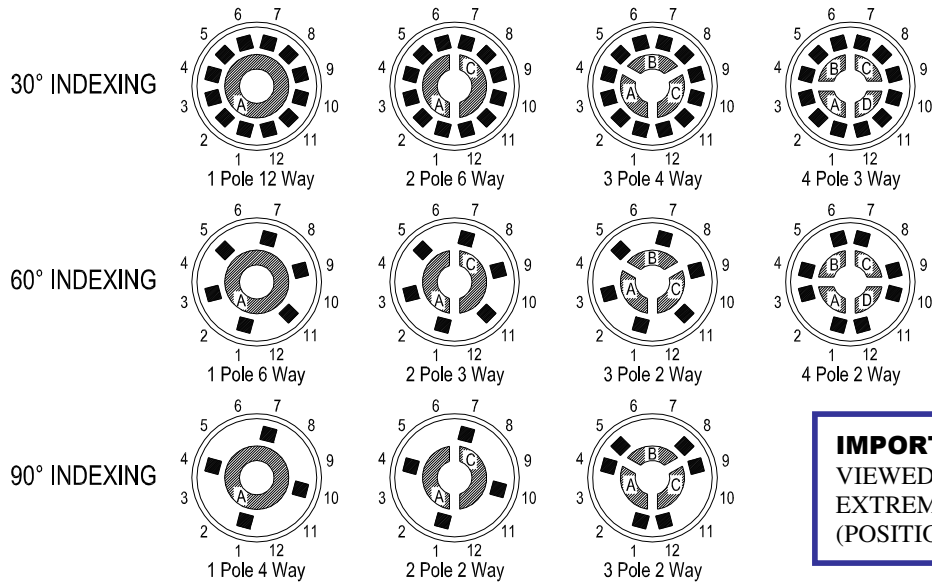

SPINDLE FLAT ANGLE - AVAILABLE IN 15° INCREMENTS

SCREWDRIVER SLOT - AVAILABLE IN 45° INCREMENTS

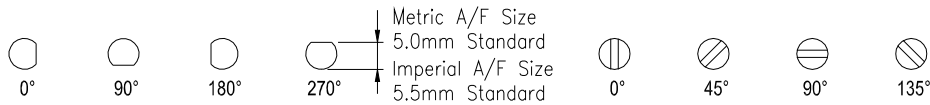

ORDERING CODE FOR NON-STANDARD SWITCHES

EXISTING CK PARTS MAY BE ORDERED AS SEALED TYPE BY CHANGING PART NUMBER TO START WITH CKS



Index Angles & NO. OF POLES	NO OF WAYS (POSITIONS)	MBB or BBM	Contact Type	Contact Plating	SPINDLE DIAM.	SPINDLE FLAT DEPTH	BUSH DIAM.	LENGTH OF SPINDLE FLAT			ANGLE OF FLAT (°)		
								A	B	C	A	B	C
A 30° 1Pole	A 2	A BBM	Solder	SILVER	A 6mm	Nil	M10	A 2	N	15	A 0	N	195
B 2	B 3	B MBB	Solder		B 6mm	5mm	M10	B 3	O	No Flat	B 15	O	
C 3	C 4	C BBM	PCB		C 6.35mm	Nil	9.52 mm	C 4	P	16	C 30	P	210
D 4	D 5	D MBB	PCB		D 6.35mm	5.5mm	9.52 mm	D 5	Q	17	D 45	Q	225
E 60° 1Pole	E 6	E BBM	Solder	GOLD PLATE				E 6	R	18	E 60	R	240
F 2	F 7	F MBB	Solder		F 7	S	19	F 75	S	255			
G 3	G 8	G BBM	PCB		G 8	T	20	G 90	T	270			
H 4	H 9	H MBB	PCB		H 9	U	21	H 105	U	285			
I 90° 1Pole	I 10	I BBM	Solder	GOLD FLASH				I 10	V	22	I 120	V	300
J 2	J 11	J MBB	Solder		J 11	W	23	J 135	W	315			
K 3	K 12	K BBM	PCB		K 12	X	24	K 150	X	330			
Z No Stop	L MBB	PCB	L 13		Y	25	L 165	Y	345				
					M 14	Z	Full	M 180					

PLEASE COMPLETE THE SPECIFICATION DRAWING IF YOUR DETAILS CANNOT BE FULLFILLED BY USING THE ORDERING CODE & CONFIRM WITH LORLIN SALES BEFORE ORDERING. TOOLING CHARGES CAN APPLY FOR SPINDLES THAT DO NOT HAVE FLATS THAT RUN THE FULL SPINDLE LENGTH

CKS ROTARY SWITCH

SPECIFICATION SHEET

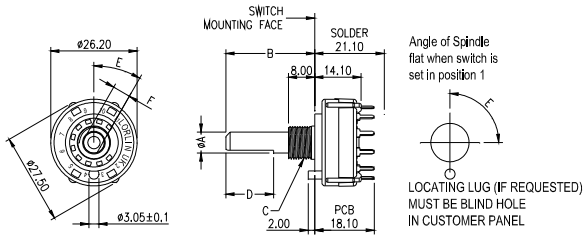

CUSTOMER TO COMPLETE OR DELETE AS REQUIRED

	A	B	C
IMPERIAL	Ø6.35		Ø9.52 x 32TPI
METRIC	Ø6.00		M10 x 0.75

	D	E	F
IMPERIAL			
METRIC			

INDEXING				INDEXING				INDEXING				INDEXING			
1 POLE				2 POLE				3 POLE				4 POLE			
POSITIONS				POSITIONS				POSITIONS				POSITIONS			
MBB	BBM	SOL	PCB	MBB	BBM	SOL	PCB	MBB	BBM	SOL	PCB	MBB	BBM	SOL	PCB
IMPORTANT! WAFERS FLATS & SLOTS VIEWED FROM THE FRONT OF SWITCH IN EXTREME ANTICLOCKWISE POSITION (POSITION 1)															
SPECIAL REQUIREMENTS															
<p>OPTIONS Stops are adjustable 2-12 positions. Continuous rotation (No Stops) available. Make before break (MBB) or Break before Make (BBM) rotors available. Solder Tag (SOL) or PCB pin (PCB) – indicate on wafer.</p>															
CUSTOMER:								DATE:				CUSTOMER REFERENCE NUMBER:			