

Dimensions: mm (IN)

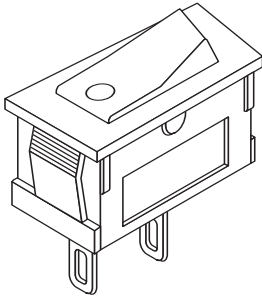

107-DS850K-01

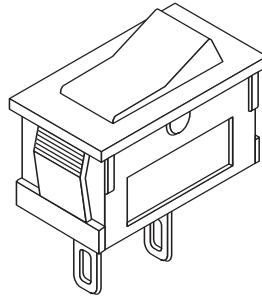

107-DS850K-00

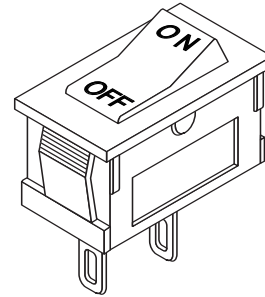

107-DS850K-02

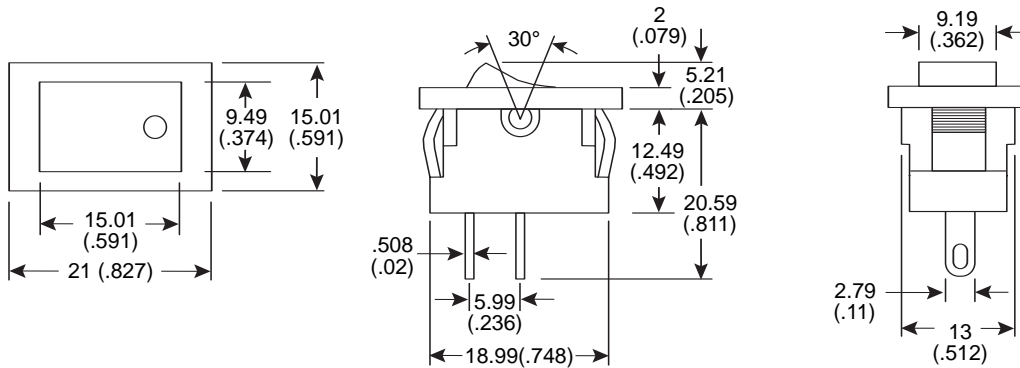

Mechanical Specifications

- Circuit: 2P SPST On-Off

Electrical Specifications

- Rating: 5A/125VAC, 3A/250VAC
- Insulation resistance: 500VDC / 100MΩ (min.)
- Dielectric Strength: 1500VAC for 1 minute
- Contact resistance: 2.5VDC 1A / 20mΩ (Max.)

Rocker Switches

107-DS850K-00, 107-DS850K-01, 107-DS850K-02



Available from Mouser Electronics

www.mouser.com

1-800-346-6873

Specifications are subject to change without notice. No liability or warranty implied by this information. Environmental compliance based on producer documentation.