

Plug-in Safety Relay

G7S

Safety Relay for Machine Control
Conforms to EN Standard

- Suitable for safety circuits in press machinery, machine tools, and other production machinery
- CE mark (conforms to prEN50205)
- Positive, force-guided contacts
- A minimum of 0.5 mm between contacts even when one contact is welded (prEN50205 Class A)
- DIN rail-mounting and panel-mounting sockets are available

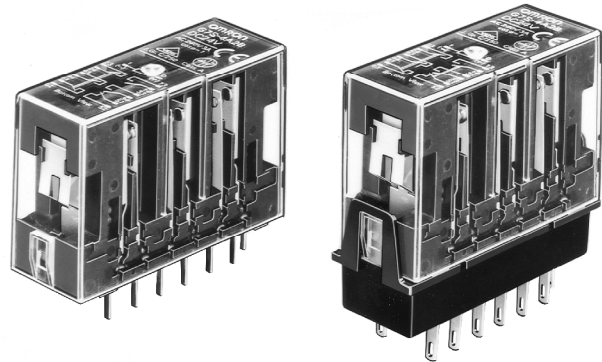

Note: Be sure to refer to the *Precautions* section.

Ordering Information

■ SAFETY RELAYS

Number of contacts	NO contacts	NC contacts	Contact form	Rated voltage (V)	Part number
6 poles	4	2	4PST-NO + DPST-NC	24 VDC	G7S-4A2B DC24
	3	3	3PST-NO + 3PST-NC		G7S-3A3B DC24

■ ACCESSORIES

Description	Part number	
Mounting sockets	DIN-rail mounting and screw mounting	P7S-14F
	Solder terminals	P7S-14A
	PCB terminals	P7S-14P
Socket mounting plate	For solder terminal sockets, holds 10 sockets	P7S-A10
Relay removal tool	Removes relay from sockets	P7S-B
DIN rail mounting track	50 cm (1.64 ft) length	PFP-50N
	1 m (3.28 ft) length	PFP-100N
	Spacer	PFP-S
	End plate	PFP-M

Specifications

■ RATINGS

Operation Coil

Rated voltage	Rated current	Coil resistance	Minimum operate voltage	Release voltage	Max. voltage	Power consumption
24 VDC	30 mA	800 Ω	80% max. (V)	10% (V)	110% (V)	Approx. 0.8 W

- Note: 1. The rated current and coil resistance are measured at a coil temperature of 23°C with tolerances of $\pm 15\%$.
 2. Performance characteristics are based on a coil temperature of 23°C
 3. The maximum voltage is based on an ambient operating temperature of 23°C maximum.

Switching Section (Contact Ratings)

Load type	Resistive load ($\cos \phi = 1$)	Inductive load ($\cos \phi = 0.4$, L/R = 7 ms)
Rated load	240 VAC: 3 A, 24 VDC: 3 A	240 VAC: 3 A, 24 VDC: 1 A
Maximum switching voltage	250 VAC, 24 VDC	
Maximum switching current	6 A	
Maximum switching capacity (reference value)	1,440 VA, 144 W	
Min. permissible load (See note.)	5 VDC, 10 mA	
Contact material	Ag + Au	

Note: The above values are based on an operating frequency of 60 operations/min.

■ CHARACTERISTICS

Contact resistance (See Note 2.)	100 m Ω max.	
Operate time (See Note 3.)	50 ms max.	
Release time (See Note 3.)	50 ms max.	
Maximum operating frequency	Mechanical	18,000 operations/hr
	Rated load	1,800 operations/hr
Insulation resistance	100 M Ω min. (at 500 VDC)	
Dielectric strength	2,500 VAC, 50/60 Hz for 1 min (1,500 VAC between contacts of same polarity)	
Vibration	Mechanical	10 to 55 Hz, 1.5-mm double amplitude
	Electrical	10 to 55 Hz, 0.75-mm double amplitude
Shock	Mechanical	1,000 m/s ² (approx. 100G)
	Electrical	100 m/s ² (approx. 10G)
Life expectancy	Mechanical	10,000,000 operations min. (at approx. 18,000 operations/hr)
	Electrical	100,000 operations min. (at the rated load and approx. 1,800 operations/hr)
Ambient temperature	Operating	-10°C to 70°C (14°F to 158°F) no icing
	Storage	-25°C to 70°C (-13°F to 158°F) no icing
Relative humidity	35% to 85% RH	
Ambient storage humidity	35% to 85% RH	
Weight	Approx. 65 g	

- Note: 1. The values given above are initial values.
 2. Measurement conditions: 5 VDC, 10 mA, voltage drops.
 3. Measurement conditions:
 Rated voltage operation
 Ambient operating temperature: 23°C (73.4°F)
 Does not include bounce time.

CHARACTERISTICS OF SAFETY RELAY SOCKET

Model	Continuous current	Dielectric strength	Insulation resistance
P7S-14□	6 A	2000 VAC for 1 min. between terminals	1000 MΩ min. (See note.)

Note: Measurement conditions: Measurement of the same points as for the dielectric strength at 500 VDC.

APPROVED STANDARDS

VDE0435 (Electrical Relays); Approved by VDE
 IEC255 (Electrical Relays); Approved by VDE
 prEN50205 (Electrical Relays); Approved by VDE
 UL508 (Industrial Control Device)
 CSA22.2 No.14 (Industrial Control Device)

Engineering Data

ELECTRICAL LIFE EXPECTANCY

(240 VAC; $\cos\phi=0.4$, $\cos\phi=1$)

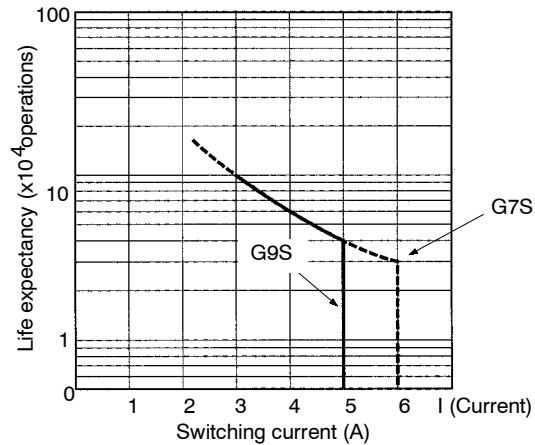

Dimensions

Unit: mm (inch)

SAFETY RELAYS

G7S-4A2B
 G7S-3A3B

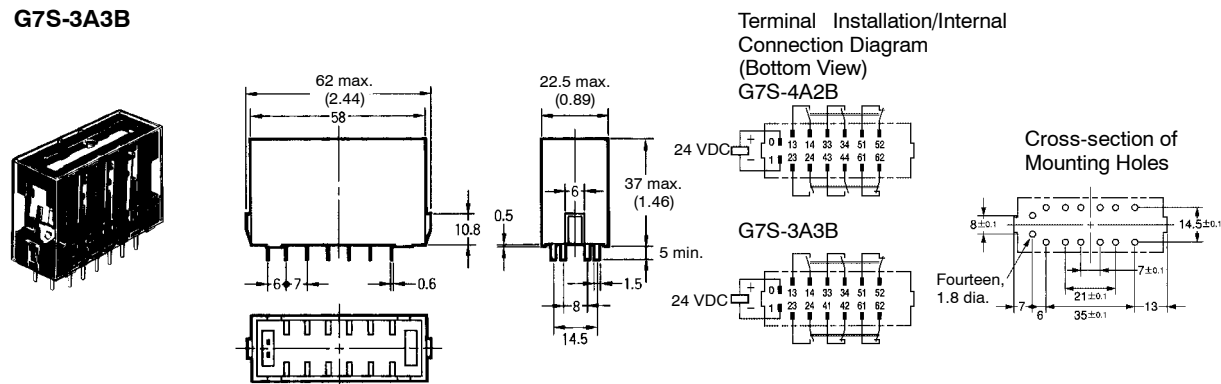

■ SAFETY RELAY SOCKETS

P7S-14F DIN Rail-mounting Socket or Screw Mounting

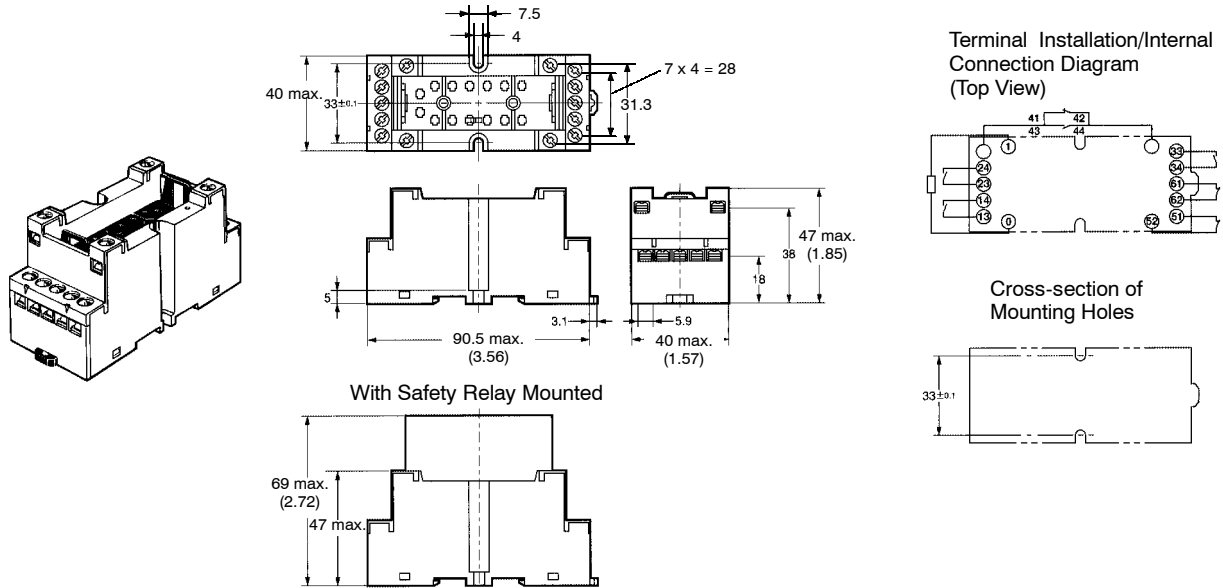

P7S-14A Panel-mounting Socket (Solder Terminals)

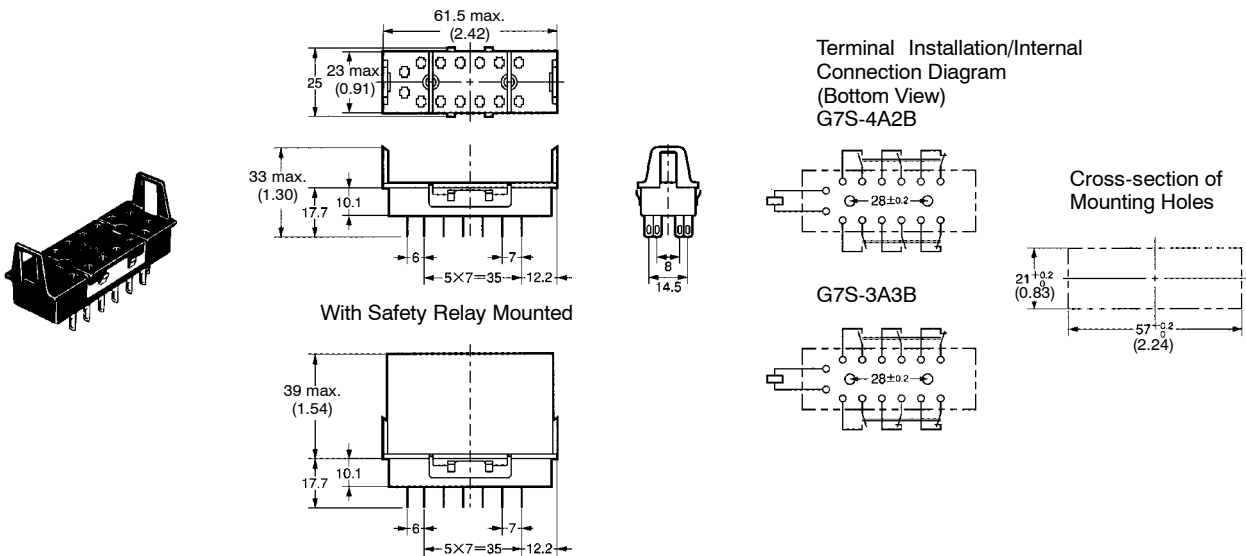

**P7S-14P PCB-mounting Socket
(PCB Terminals)**

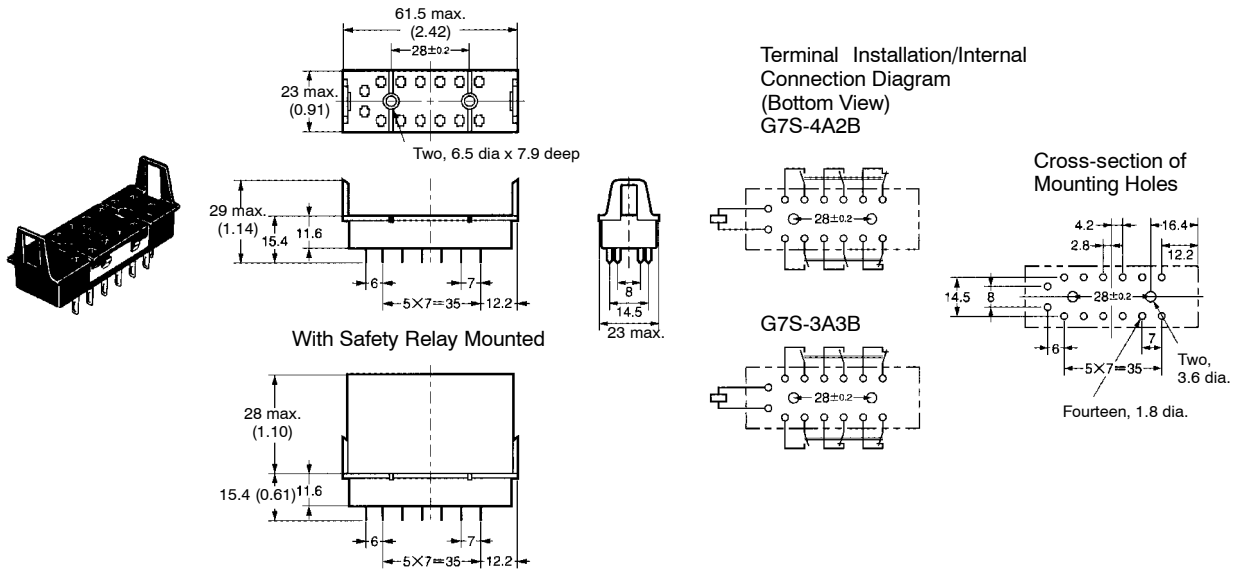

■ **SOCKET MOUNTING PLATE**

P7S-A10 (Special Mounting Plate for P7S-14A)

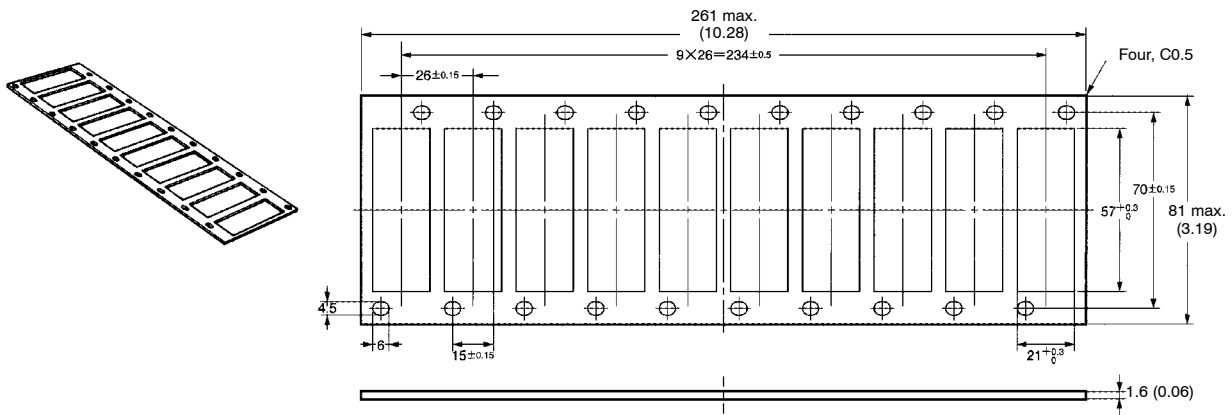

■ **RELAY REMOVAL TOOL**

P7S-B

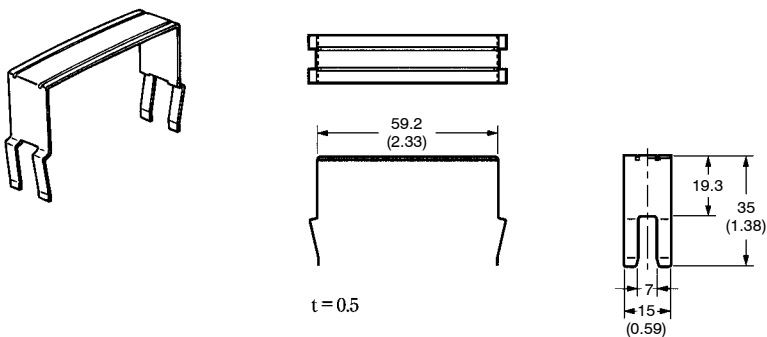

Precautions

■ POSITIVE GUIDED CONTACTS

When NO contacts are welded, the coil will be non-energized so all NC contacts will maintain a distance between the contacts of 0.5 mm minimum. Likewise if NC contacts are welded, the coil will be energized so all contacts will maintain a distance between each other of 0.5 mm minimum.



Caution

Do not touch the terminal area of the Relays or the socket terminal area (charged area) while power is ON. Electric shock will result.

Safety Relays

A Safety Relay is a relay with which a safety circuit can be configured. For common precautions when using and handling relays, consult Omron.

Contacts

The coil terminals have polarity (positive and negative). Operation is not possible if these are connected in reverse.

NOTE: DIMENSIONS SHOWN ARE IN MILLIMETERS. To convert millimeters to inches divide by 25.4.

OMRON[®]
OMRON ELECTRONICS LLC
One East Commerce Drive
Schaumburg, IL 60173
1-800-55-OMRON

OMRON ON-LINE
Global - <http://www.omron.com>
USA - <http://www.omron.com/oei>
Canada - <http://www.omron.com/oci>

OMRON CANADA, INC.
885 Milner Avenue
Scarborough, Ontario M1B 5V8
416-286-6465