

INTERFACE BOARDS FOR 24V FTP-609 Series

FTP-629DCL/ DSL

■ INTERFACE

1. Centronics standard

(1) Connector (CN1)

Connector part number : BM30B-SRDS-G-TFC (J.S.T.) or equivalent

Mating connector part number : SHDR-30V-S-B (J.S.T.) or equivalent

(2) Connector pin assignment

No.	Signal	I/O	Contents	No.	Signal	I/O	Contents
1	$\overline{\text{PRSTB}}$	I	Data strobe	2	$\overline{\text{PRSTB-RET}}$	—	Connected to logic GND
3	PRDT0	I	Data 0	4	PRDT0-RET	—	Connected to logic GND
5	PRDT1	I	Data 1	6	PRDT1-RET	—	Connected to logic GND
7	PRDT2	I	Data 2	8	PRDT2-RET	—	Connected to logic GND
9	PRDT3	I	Data 3	10	PRDT3-RET	—	Connected to logic GND
11	PRDT4	I	Data 4	12	PRDT4-RET	—	Connected to logic GND
13	PRDT5	I	Data 5	14	PRDT5-RET	—	Connected to logic GND
15	PRDT6	I	Data 6	16	PRDT6-RET	—	Connected to logic GND
17	PRDT7	I	Data 7	18	PRDT7-RET	—	Connected to logic GND
19	$\overline{\text{ACKNLG}}$	O	Data input acknowledge	20	$\overline{\text{ACKNLG-RET}}$	—	Connected to logic GND
21	BUSY	O	Busy	22	BUSY-RET	—	Connected to logic GND
23	RINF2	O	Printer status	24	$\overline{\text{INPRM-RET}}$	—	Connected to logic GND
25	$\overline{\text{SLCTIN}}$	I	Printer select	26	$\overline{\text{INPRM}}$	I	Reset
27	RINF1	O	Printer status	28	RINF3	O	Printer status
29	$\overline{\text{ATF}}$	I	Paper feed request	30	GND	—	Logic GND

- Notes:
- Symbol “—” means a negative logic signal.
 - “-RET” signal is a return signal of the twisted pair cable.
 - “I” or “O” means a signal direction from the interface board side.

(3) Connector pin number

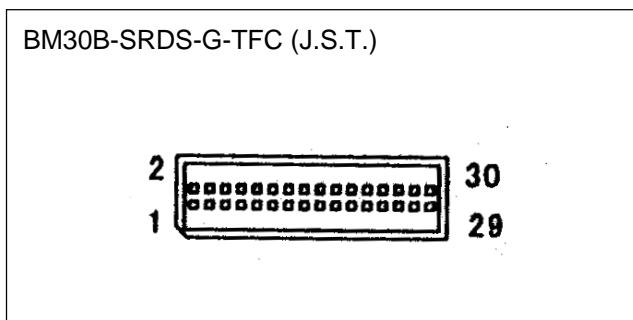

(4) Data input signal timing

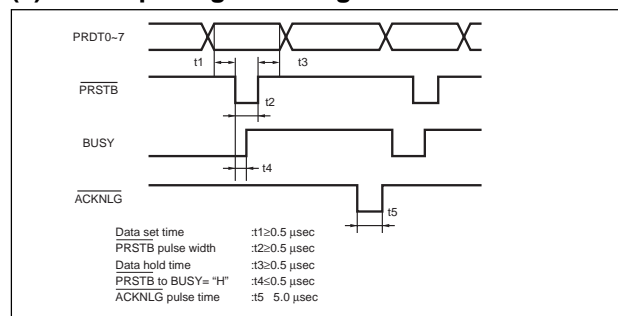

(5) Printer Status Signal

	Error	RINF1	RINF2	RINF3
1	Paper out	Low	High	Low
2	Paper near-end	High	High	Low
3	Head-up	High	Low	Low
4	Abnormal head temperature	High	Low	High
5	Abnormal head voltage	Low	High	High
6	Hardware abnormality	High	High	High
7	Mark detection abnormality	Low	Low	Low
8	Normal	Low	Low	High

2. RS-232C standard

(1) Connector (CN2)

Connector part number : B8B-ZR-SM3A (J.S.T.) or equivalent

Mating connector part number : ZHR-8 (J.S.T.) or equivalent

(2) Connector pin assignment

No	Signal	I/O	Contents	No	Signal	I/O	Contents
1	RD	I	Receive Data	2	TD	O	Transmission data
3	DTR	O	Data terminal ready	4	GND		Signal ground
5	DSR	I	Data set ready	6	$\overline{\text{SLCTIN}}$	I	Printer select
7	$\overline{\text{INPRM}}$	I	Reset	8	$\overline{\text{AFT}}$	I	Paper feed request

Notes:

- Symbol “ $\overline{\text{—}}$ ” means a negative logic signal.
- “I” or “O” means a signal direction from the interface board side.

■ CONNECTOR PIN ASSIGNMENT OF INTERFACE BOARD

1. Thermal head control circuit side (CN3)

Part number : 52610-3090 (Molex) or equivalent

No	Signal	I/O	Contents	No	Signal	I/O	Contents
1	HUP	O	Platen open signal	2	+5 V	-	Power for logic
3	+24V	-	Power for thermal head	4	+24 V	-	Power for thermal head
5	+24V	-	Power for thermal head	6	+24 V	-	Power for thermal head
7	HDO	O	Data out	8	STB2/STB3	O	Print enable 2/3
9	STB3/STB4	O	Print enable 3/4	10	+5 VDD	-	Power for thermal head
11	GND	-	Head GND	12	GND	-	Head GND
13	GND	-	Head GND	14	GND	-	Head GND
15	GND	-	Head GND	16	GND	-	Head GND
17	GND	-	Head GND	18	GND	-	Head GND
19	GND	-	Head GND	20	GND	-	Head GND
21	TMP	I	Thermistor input	22	STB1	O	Print enable 1
23	NC /STB2	O	Not connected / Head control signal 2*	24	LAT	O	Print data latch
25	HCLK	O	Clock signal	26	HDI	I	Data input
27	+24V	-	Power for thermal head	28	+24V	-	Power for thermal head
29	+24V	-	Power for thermal head	30	+24V	-	Power for thermal head

*: FTP629MCL: NC FTP-639MCL: STB4

2. Motor, Sensor (CN4)

Connector on circuit side : 52610-1090 (Molex) or equivalent

No.	Signal	I/O	Contents	No.	Signal	I/O	Contents
1	NC	-	Not connected	2	MTMP	I	Motor temperature signal
3	GND +5V	-	Logic ground	4	MT/A	I/O	Motor coil excitation A
5	MT/A	I/O	Motor coil excitation A	6	MT/B	I/O	Motor coil excitation B
7	MT/B	I/O	Motor coil excitation B	8	PESK	-	Logic
9	+5V	-	Power for logic	10	PES	I	Paper out signal

■ CONNECTOR PIN ASSIGNMENT OF INTERFACE BOARD

3. Connector for Cutter (CN5)

B4B-PH-SM3-TP (J.S.T) or equivalent (P.C.B. side)

No	Signal	I/O	Contents	No	Signal	I/O	Contents
1	CHP	I	Cutter home position signal	2	GND	I	Ground
3	MT+	O	Cutter motor driving signal	4	MT-	O	Cutter motor driving signal

4. Connector for Logic Power Supply (CN6)

*B3B-PH-SM3-TB (J.S.T) or equivalent (P.C.B. side)

No	Signal	I/O	Contents	No	Signal	I/O	Contents
1	+V5	-	Power for logic	2	NC	-	No connection
3	GND	-	Ground of logic				

5. Connector for Head, Motor Power Supply (CN7)

*S6B-XH-SM3-TB (J.S.T) or equivalent (P.C.B. side)

No	Signal	I/O	Contents	No	Signal	I/O	Contents
1	+24V	-	Power for head	2	+24V	-	Power for head
3	+24V	-	Power for head	4	GND	-	Ground
5	GND	-	Ground	6	GND	-	Ground

6. Connector for Paper Near-End sensor (CN8)

*B2B-PH-SM3-TB (J.S.T) or equivalent (P.C.B. side)

No	Signal	I/O	Contents	No	Signal	I/O	Contents
1	+V5	-	Power for logic	2	NES	I	Paper near-end signal

■ COMMANDS

Command	Contents
HT	Moves print position to the next tab.
LF	Line feed.
FF	Feeds forms (new page).
ESC EM+n	Setting the amount of the feeding at automatic paper feed.
ECS RS	Sets reverse printing.
ESC US	Resets reverse printing.
ESC ! + n	Sets print mode.
ESC % + n	External registration character specification/cancellation.
ESC & +y+c1+c2+x+d1to dn	External registration character definition.
ESC *+m+n1+n2+d1+dN	Sets bit image mode.
ESC 2	Sets 1/6 inch line feed length.
ESC 3+n	Sets the line feed length.
ESC ? + n	External registration character deletion.
ESC @	Printer initialization.
ESC A+n	Sets the space between the line.
ESC C+n	Sets the page length by character line.
ESC D+d1+dN +NUL	Sets the tab position.
ESC J+n	Feeds paper in forward direction and prints.
ESC K+n	Reverse paper feed.
ESC R+n	Selects international character.
ESC V+n	Right Rotation 90° specification / cancellation.
ESC X+m+n	Setting the turning time of the motor excitation.
ESC c+1+n	Sets internal processing.
ESC d+n	Printing and n-line feeding.
ESC e+n	Prints and reverse feeds n-lines.
ECS s+n	Sets printing speed.
ECS t+n	Character code table selection.
ESC {+n	Sets/resets upside down printing.
FS !+n	Kanji printing mode collective specification (valid only for FTP-629DSL038).
FS &	Kanji printing mode specification (valid only for FTP-629DSL038).
FS *+m+n1+n2+d1 to dn	High speed collective image printing specified.

Commands continued

Command	Contents
FS .	Kanji printing mode cancellation (valid only for FTP-629DSL038).
FS 9+n	Sets the detection functions.
FS C+n	Kanji code system selection.
FS E+n	Correction of impressed energy.
FS W+n	Kanji double height and width printing specification/cancellation.
FS r+n*1	Parameter transmission.
GS &+m+x+y1+y2+d1 to dN	Registration of image data.
GS '+m+n	Prints registered image data.
GS <	Line feeds to the next mark.
GS A+m+n	Sets the line feed length after mark detection.
GS E+n	Sets print quality.
GS V+n+m	Paper cutting (this command is only available for chip).
GS e+n+m	Sets bar code width.
GS h+n	Sets bar code height.
GS k+m+n+d1+dN	Selects bar code type and prints.
GS w+n	Sets bar code length.
GS a+n*1	Setting and cancellation of auto status transmission.

*1: These commands are valid with FTP-629DSL series.

■ OPTIONS

1. Cable

Name		Part Number	Cable length
Interface cable (board to mechanism)	centronics	FTP-628Y202	500mm (19.7 inch)
	RS-232C	FTP-628Y302	500mm (19.7 inch)
Power supply cable	logic	FTP-629Y401	300mm (11.8 inch)
	motor	FTP-629Y601	300mm (11.8 inch)

2. Paper Holder

Name	Part Number
Flange	FTP-040HF
Stand	FTP-040HS

Fujitsu Components International Headquarter Offices

Japan

Fujitsu Component Limited
Gotanda-Chuo Building
3-5, Higashigotanda 2-chome, Shinagawa-ku
Tokyo 141, Japan
Tel: (81-3) 5449-7010
Fax: (81-3) 5449-2626
Email: promothq@ft.ed.fujitsu.com
Web: www.fcl.fujitsu.com

North and South America

Fujitsu Components America, Inc.
250 E. Caribbean Drive
Sunnyvale, CA 94089 U.S.A.
Tel: (1-408) 745-4900
Fax: (1-408) 745-4970
Email: marcom@fcai.fujitsu.com
Web: www.fcai.fujitsu.com

Europe

Fujitsu Components Europe B.V.
Diamantlaan 25
2132 WV Hoofddorp
Netherlands
Tel: (31-23) 5560910
Fax: (31-23) 5560950
Email: info@fceu.fujitsu.com
Web: www.fceu.fujitsu.com

Asia Pacific

Fujitsu Components Asia Ltd.
102E Pasir Panjang Road
#04-01 Citilink Warehouse Complex
Singapore 118529
Tel: (65) 6375-8560
Fax: (65) 6273-3021
Email: fcac@fcal.fujitsu.com
www.fcal.fujitsu.com

© 2005 Fujitsu Components America, Inc. All company and product names are trademarks or registered trademarks of their respective owners. Rev. 05/05/2005.