

REV.	DESCRIPTION	DATE	APPROVED
A	Engineering Update w/o Changes	02/23/04	M. C.
B	Changed Outer Radius to Diameter (.280)	12/21/07	M. C.

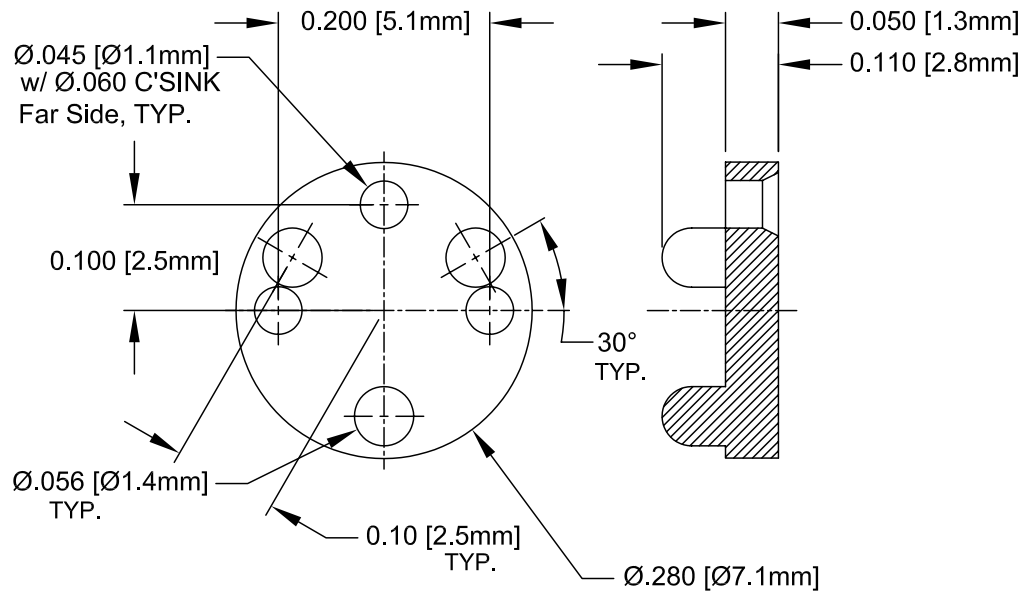

2. MATERIAL: NYLON 6/6, 94V-2, WHITE. BIVAR MATERIAL CODE 04-WE.
BASF ULTRAMID NYLON 6/6 A3K WHITE.
1. GENERAL SPECIFICATIONS: BIVAR MOLDED COMPONENT SPECIFICATION BV00-E101.

STANDARD TOLERANCE (UNLESS OTHERWISE SPECIFIED)		BIVAR®	
DECIMALS	ANGULAR	4 THOMAS, IRVINE, CA, 92618	
.X ±.1	X° ±1°	TEL: (949) 951-8808 FAX: (949) 951-3974	
.XX ±.01		TITLE: PERM-O-PAD TO-5 MOUNT	
.XXX ±.005		DESIGNED: Shane Irving	DATE: 05/10/99
		CHECKED: D. Green	DATE: 02/23/04
		PART NO: 510-110	REVISION: B
		CAGE CODE : 32559	SHEET # 1 OF 1
		CAD GENERATED DOCUMENT, DO NOT MEASURE DRAWING.	