

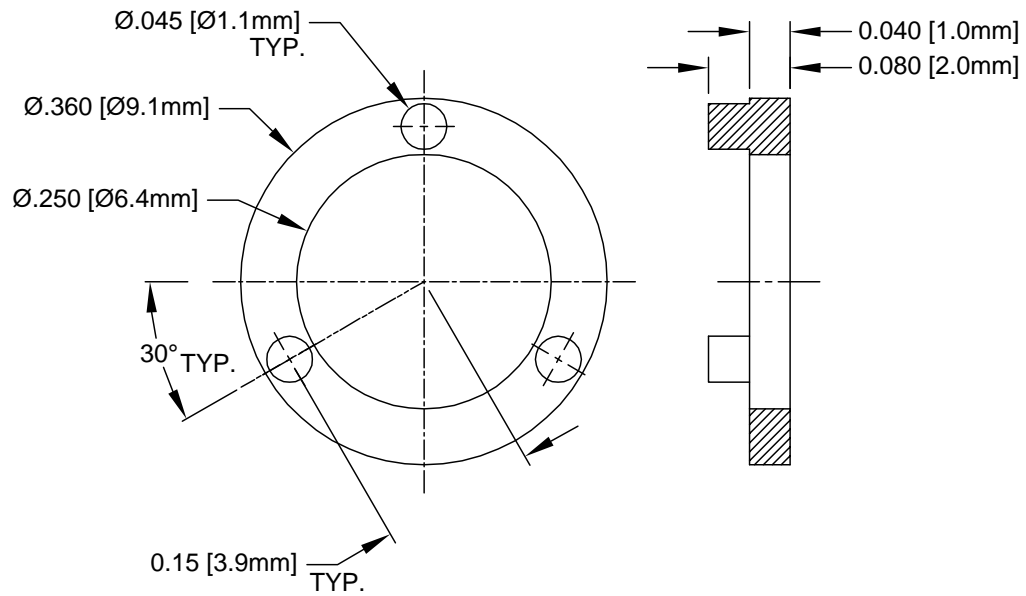

REV.	DESCRIPTION	DATE	APPROVED
A	Engineering Update w/o Changes	02/23/04	M. C.



- 2. MATERIAL: NYLON 6/6, 94V-2, WHITE. BIVAR MATERIAL CODE 04-WE.  
BASF ULTRAMID NYLON 6/6 A3K WHITE.
- 1. GENERAL SPECIFICATIONS: BIVAR MOLDED COMPONENT SPECIFICATION BV00-E101.

STANDARD TOLERANCE (UNLESS OTHERWISE SPECIFIED)		 4 THOMAS, IRVINE, CA. 92618 TEL: (949) 951-8808 FAX: (949) 951-3974	
DECIMALS	ANGULAR		
.X $\pm .1$	$X^\circ \pm 1^\circ$	TITLE: PERM-O-PAD TO-5 AND IC MOUNT	
.XX $\pm .01$		DESIGNED: <b>Shane Irving</b>	DATE: <b>11/09/99</b>
.XXX $\pm .005$		CHECKED: <b>D. Green</b>	DATE: <b>02/23/04</b>
		PART NO: <b>600-080</b>	REVISION: <b>A</b>
		CAGE CODE : <b>32559</b>	SHEET # <b>1</b> OF <b>1</b>
CAD GENERATED DOCUMENT. DO NOT MEASURE DRAWING.			