

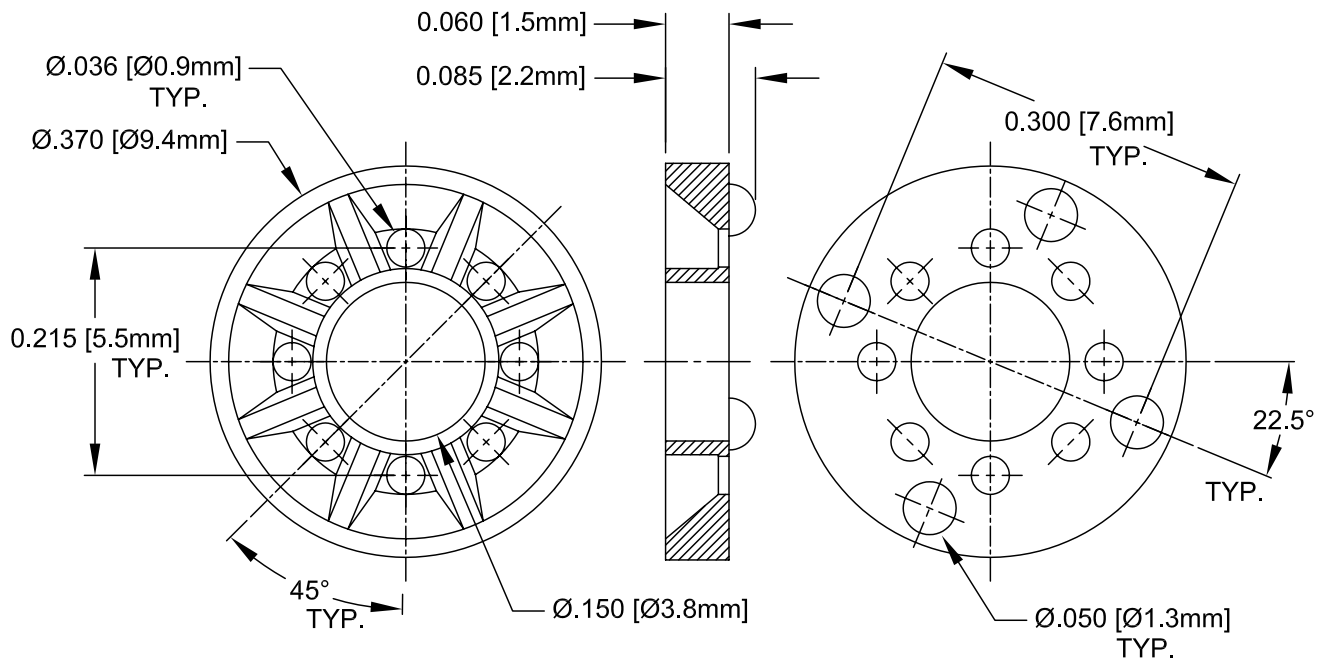

REV.	DESCRIPTION	DATE	APPROVED
A	Engineering Update w/o Changes	02/23/04	M. C.
B	Drawing Correction	02/16/06	M. C.
C	Added Note	03/13/08	M. C.



Note: Parts Dyed Blue

2. MATERIAL: NYLON 6/6, 94V-2, NATURAL. BIVAR MATERIAL CODE 21-NL. TICONA NYLON 1310, NYLON 6/6, NATURAL.
1. GENERAL SPECIFICATIONS: BIVAR MOLDED COMPONENT SPECIFICATION BV00-E101.

STANDARD TOLERANCE (UNLESS OTHERWISE SPECIFIED)		 4 THOMAS, IRVINE, CA, 92618 TEL: (949) 951-8808 FAX: (949) 951-3974	
DECIMALS	ANGULAR		
.X $\pm .1$	$X^\circ \pm 1^\circ$		TITLE: PERM-O-PAD TO-5 AND IC MOUNT
.XX $\pm .01$			PART NO: 605-085
.XXX $\pm .005$		DESIGNED: Shane Irving	DATE: 07/18/00
		CHECKED: D. Green	DATE: 02/23/04
		CAGE CODE : 32559	SHEET # 1 OF 1
CAD GENERATED DOCUMENT, DO NOT MEASURE DRAWING.			