

ALL DIMENSIONS IN INCHES

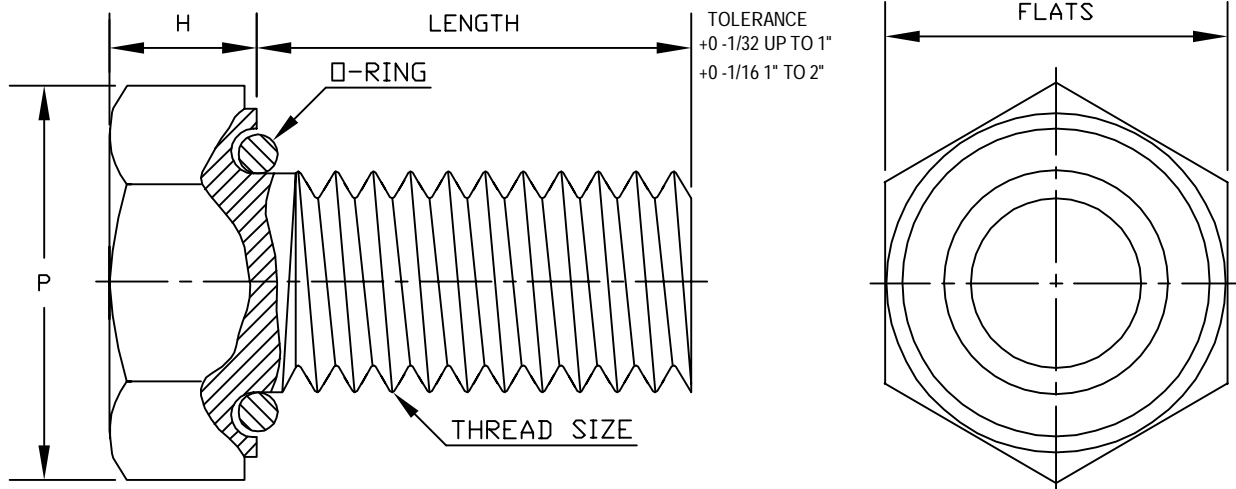

THREAD SIZE	P NOM.	H max	Flats max	RECOM. CLEAR. HOLE		LENGTH
				MIN.	MAX.	
1/4-28 UNF 2A	0.510"	0.163"	0.440"	0.265"	0.269"	3/8" to 3/4" Incl.
1/4-20 UNC 2A	0.510"	0.163"	0.440"	0.265"	0.269"	3/8" to 3/4" Incl.
5/16-24 UNF 2A	0.580"	0.211"	0.502"	0.332"	0.336"	1/2" to 7/8" Incl.
5/16-18 UNC 2A	0.580"	0.211"	0.502"	0.332"	0.336"	3/8" to 7/8" Incl.
3/8-24 UNF 2A	0.650"	0.243"	0.565"	0.395"	0.399"	5/8" to 1" Incl.
3/8-16 UNC 2A	0.650"	0.243"	0.565"	0.395"	0.399"	1/2" to 1" Incl.
7/16-20 UNF 2A	0.720"	0.291"	0.627"	0.467"	0.471"	5/16" to 1" Incl.
7/16-14 UNC 2A	0.720"	0.291"	0.627"	0.467"	0.471"	5/16" to 1" Incl.
1/2-20 UNF 2A	0.870"	0.323"	0.752"	0.530"	0.534"	1/2" to 1 1/4" Incl.
1/2-13 UNC 2A	0.870"	0.323"	0.752"	0.530"	0.534"	3/4" to 1 1/4" Incl.

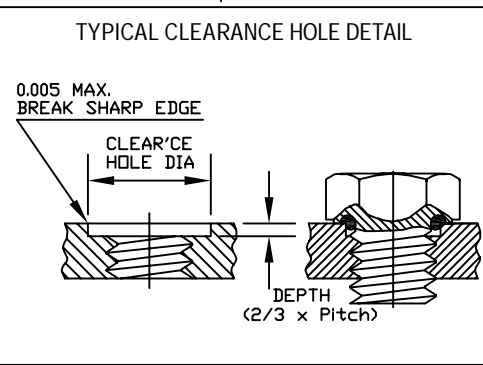

STANDARD SPECIFICATIONS & COMMON OPTIONS (HOW TO ORDER)

STD. SCREW MATERIAL: TYPE 18/8 STAINLESS STEEL PER DFARS (OTHER MATERIALS AVAILABLE)
 STD. SCREW FINISH: NATURAL (PASSIVATED PER MIL-STD-171 UNLESS OTHERWISE SPECIFIED)
 STD. O-RING MATERIAL: SILICONE RUBBER (SEE TABLE FOR O-RING OPTIONS)

SAMPLE CATALOG NO.		ST1/4-20X1/2-2701-BLKOX
SCREW TYPE	ST	HEXAGON HEAD SEELBOLTS
THREAD	1/4-20	ENTER BASIC THREAD SIZE
	X	
LENGTH	1/2	ENTER LENGTH
O-RING SUFFIX	-2701	ENTER FROM TABLE
OPTIONS	-BLKOX	ENTER FROM TABLE

AVAILABLE O-RING MATERIALS		
Compound Suffix	Material	Service Temp.
-2701	Silicone Rubber	-150°F to 500°F -101°C to 260°C
-2615	Fluoro-Silicone Rubber	-78°F to 450°F -61°C to 232°C
-5701	Viton® A	-20°F to 400°F -29°C to 204°C
-4601	Buna N (NBR)	-65°F to 250°F -54°C to 121°C
-3701	Neoprene (EPR)	-65°F to 300°F -54°C to 149°C
-7601	Ethylene Propylene (EPDM)	-65°F to 300°F -54°C to 149°C

COMMON OPTIONS	
SUFFIX	DESCRIPTION
-BLKOX	BLACK OXIDE PER MIL-C-13924A, CLASS 2
-NY	LOCKING NYLON PELLET
-LY	LOCKING NYLON STRIP
-TP	LOCKING NYLON STD. PATCH
-HTP	HIGH TEMP. LOCKING NYLON PATCH

J	ADDED "PER DFARS" FOR THE SCREW MATERIAL	S. GOK	07.02.09
I	NEW DRAWING FORMAT	S. GOK	01.21.09
H	CAD COMPUTER GENERATED		12-23-02
REV.	DESCRIPTION		DATE
	TITLE: SEELBOLT®, HEX HEAD THREADED TO HEAD	ENG. DWN. FRUMENTI	6-23-60
	MAT'L: AS NOTED	CHKD.	
	FINISH: AS NOTED	SCALE	DWG. NO. ST-0-0-00-0
	APM-HEXSEAL CORPORATION		

THIS DRAWING COVERS PROPRIETARY ITEM AND IS THE PROPERTY OF THE APM-HEXSEAL CORPORATION.
 THIS DRAWING IS NOT TO BE COPIED OR USED WITHOUT THE WRITTEN APPROVAL OF AN OFFICER OF THE APM-HEXSEAL CORPORATION.