

REV.	DATE	DESCRIPTION
A	04/05/03	UPDATE DRAWING FORMAT

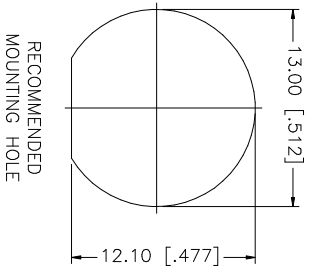
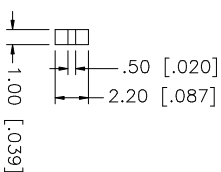
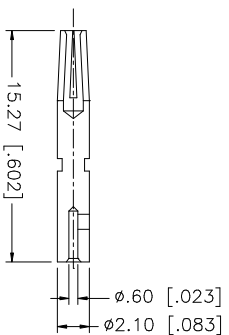
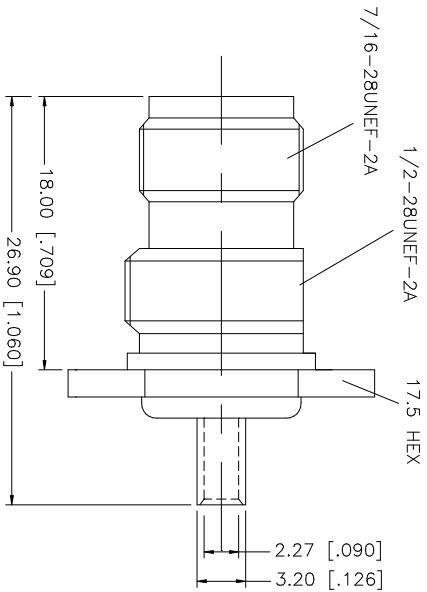
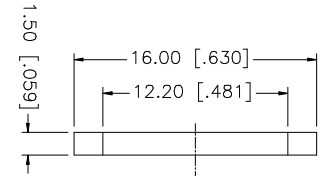
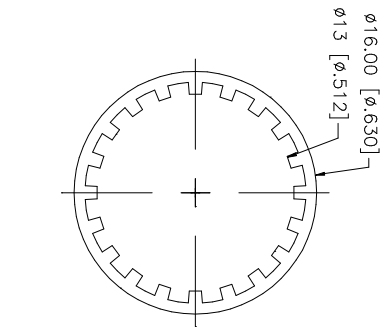
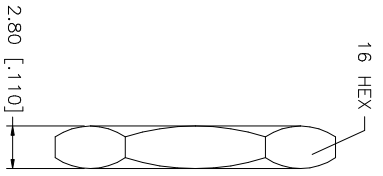
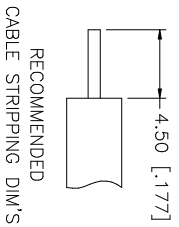

- NOTE:
1. CRIMPED CONTACT PIN
HEX CRIMP SIZE .068"
 2. MAX. PANEL THICKNESS = 3.5mm

QTY	DESCRIPTION	MATERIAL	FINISH	DO NOT SCALE DRAWING	APPROVALS	DATE	PART DESCRIPTION	DWG. NO.	REV.	SIZE	SCALE
1	INSULATOR	TEFLON	NATURAL	UNLESS OTHERWISE SPECIFIED DIMENSIONS ARE IN MILLIMETERS. DIMENSIONS IN [] ARE IN INCHES AND FOR CUSTOMER REFERENCE ONLY. UNLESS OTHERWISE SPECIFIED TOLERANCES FOR MILLIMETERS ARE:	G.R.S.	04/05/03	Amphenol Connex TNC BULKHEAD SOLDER JACK (FOR .085", .086" CABLE)	122400.DWG	A	A	NA
1	CONTACT PIN	PHOS. BRONZE	GOLD	0.5 - 8mm ± 0.20mm							
1	HEX NUT	BRASS	NICKEL	8 - 30mm ± 0.40mm							
1	LOCK WASHER	BRASS	NICKEL	30 - 120mm ± 0.50mm							
1	GASKET	RUBBER	RED	UNLESS OTHERWISE SPECIFIED TOLERANCES FOR INCHES ARE:							
1	INSULATOR	TEFLON	NATURAL	.020 - .315 = ± 0.007"	SHEET 1 OF 1						
1	HOUSING/BODY	BRASS	NICKEL	.315 - 1.180 = ± 0.015" 1.180 - 4.724 = ± 0.020"							
	DESCRIPTION	MATERIAL	FINISH	DO NOT SCALE DRAWING	CAD FILE						
					C:/122/122400.DWG						