

Customer Information Sheet

DRAWING No.: H8504-XX

SHEET 2 OF 2

IF IN DOUBT - ASK

©

NOT TO SCALE

THIRD ANGLE PROJECTION

ALL DIMENSIONS IN mm

ORDER CODE:

H8504-XX

FINISH:

01 = 100% TIN SHELL, GOLD CLIP
05 = GOLD SHELL, GOLD CLIP
46 = 100% TIN SHELL, 100% TIN CLIP

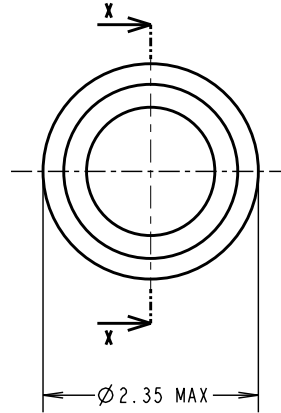
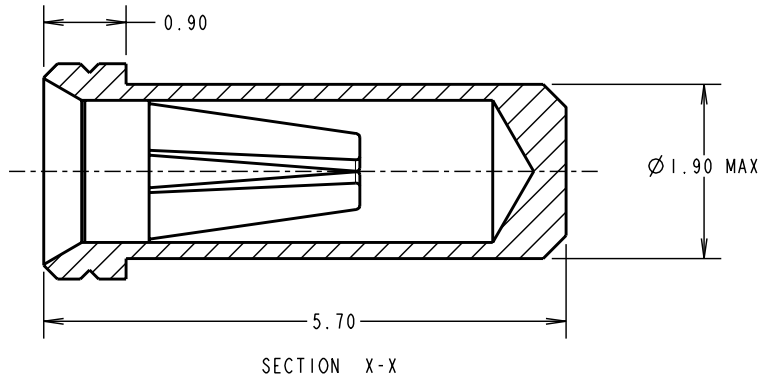

SPECIFICATION:

MATERIAL:
CONTACT SHELL = BRASS
CONTACT CLIP = BERYLLIUM COPPER

FINISH:
01 = 4μ 100% TIN SHELL, 0.15μ GOLD CLIP
05 = 0.1μ GOLD SHELL, 0.15μ GOLD CLIP
46 = 4μ 100% TIN SHELL, 3μ 100% TIN CLIP

ELECTRICAL:
CURRENT RATING AT 25°C = 10A MAX
CURRENT RATING AT 85°C = 7.5A MAX
CONTACT RESISTANCE = 25 mΩ MAX

MECHANICAL:
INSERTION FORCE (∅0.8mm GAUGE) = 5N MAX, 1.5N MIN
WITHDRAWAL FORCE (∅0.8mm GAUGE) = 3.0N MAX, 1.0N MIN

DURABILITY:
01, 05 = 1000 OPERATIONS
46 = 100 OPERATIONS

ENVIRONMENTAL:
OPERATING TEMPERATURE = -55°C TO +125°C

PACKING:
BAG

NOTES:

- FOR ELECTRICAL/MECHANICAL SPECIFICATION, SEE COMPONENT SPECIFICATION CO10XX (LATEST ISSUE).
- MAXIMUM PIN LENGTH = 4.65mm.
- RECOMMENDED MOUNTING HOLE SIZE = ∅2.01-1.91mm.
- RECOMMENDED MATING PIN SIZE = ∅0.85-0.60mm.
- MAXIMUM CONTACT DEPTH = 3.30mm.

SM	12	16.06.10	10837
NAME	ISS.	DATE	C/NOTE
APPROVED: S. MCCULLAGH			
CHECKED: R. ADDE			
DRAWN: A. J. FILLINGHAM			
CUSTOMER REF.:			
ASSEMBLY DRG:			

HARWIN

HARWIN USA
TEL: 603 893 5376
FAX: 603 893 5396
mis@harwin.com

HARWIN Europe (UK)
TEL: 023 9231 4545
FAX: 023 9231 4590
mis@harwin.co.uk

HARWIN Asia
TEL: +65 6 779 4909
FAX: +65 6 779 3868
mis@harwin.com.sg

THIS DRAWING AND ANY INFORMATION OR DESCRIPTIVE MATTER SET OUT HEREON ARE CONFIDENTIAL AND COPYRIGHT PROPERTY OF THE HARWIN GROUP AND MUST NOT BE DISCLOSED, LOANED, COPIED OR USED FOR MANUFACTURING, TENDERING OR FOR ANY OTHER PURPOSE WITHOUT THEIR WRITTEN PERMISSION.

TOLERANCES

X. = ±1mm
X.X = ±0.25mm
X.XX = ±0.10mm
X.XXX = ±0.01mm

ANGLES = ±5°
UNLESS STATED

MATERIAL:

SEE ABOVE

FINISH: SEE ABOVE

S/AREA: mm²

TITLE:

∅0.8mm SOCKET ASSEMBLY

DRAWING NUMBER:

H8504-XX

SHT
2
OF 2