

REV.	DESCRIPTION	DATE	APPROVED
A	Engineering Update w/o Changes	02/24/04	M. C.

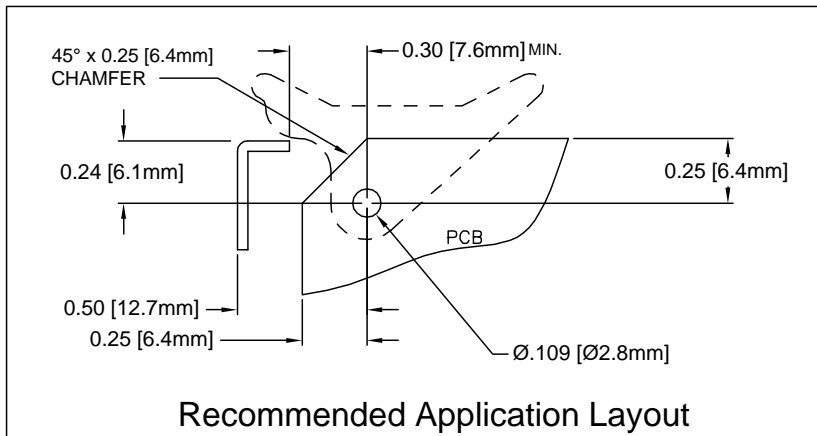
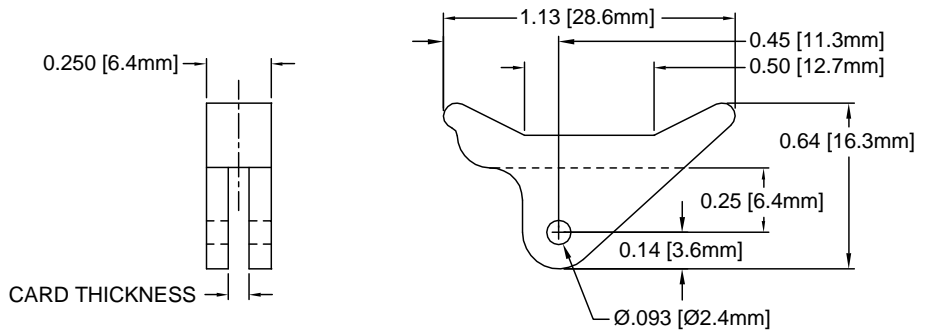

PART NO.	BIVAR MT'L CODE	CARD THICK.
CP-26 NT	03-NL (#2, Natural)	1/16" (1.6mm)
CP-26 BK	03-NL-BK (#3, Black)	
CP-26 WE	04-WE (#4, White)	
CP-29 NT	03-NL (#2, Natural)	3/32" (2.4mm)
CP-29 BK	03-NL-BK (#3, Black)	
CP-29 WE	04-WE (#4, White)	

- MATERIAL: NYLON 6/6, 94V-2, WHITE. BIVAR MATERIAL CODE 04-WE. BASF ULTRAMID NYLON 6/6 A3K WHITE.
- MATERIAL: NYLON 6/6, 94V-2, BLACK. BIVAR MATERIAL CODE 03-NL-BK. BASF ULTRAMID NYLON 6/6 A3K NATURAL W/BLACK PIGMENT ADDED.
- MATERIAL: NYLON 6/6, 94V-2, NATURAL. BIVAR MATERIAL CODE 03-NL. BASF ULTRAMID NYLON 6/6 A3K NATURAL.
- GENERAL SPECIFICATIONS: BIVAR MOLDED COMPONENT SPECIFICATION BV00-E101.

STANDARD TOLERANCE (UNLESS OTHERWISE SPECIFIED)		 4 THOMAS, IRVINE, CA. 92618 TEL: (949) 951-8808 FAX: (949) 951-3974			
DECIMALS	ANGULAR				
.X ± .1	X° ± 1°	TITLE: CIRCUIT BOARD CARD EJECTOR			
.XX ± .01					
.XXX ± .005		DESIGNED: Shane Irving	DATE: 04/20/98	PART NO: CP-2X	REVISION: A
CHECKED: D. Green		DATE: 02/24/04	CAGE CODE : 32559 SHEET # 1 OF 1		
CAD GENERATED DOCUMENT. DO NOT MEASURE DRAWING.					