

REV.	DESCRIPTION	DATE	APPROVED
B	Engineering Update w/o Changes	02/27/04	M. C.

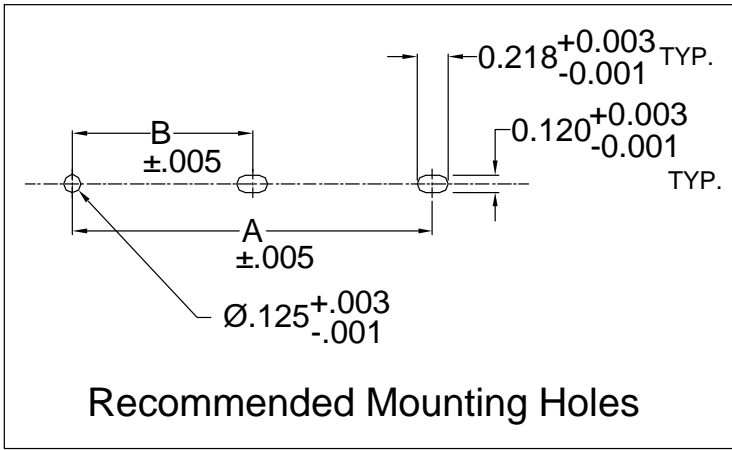
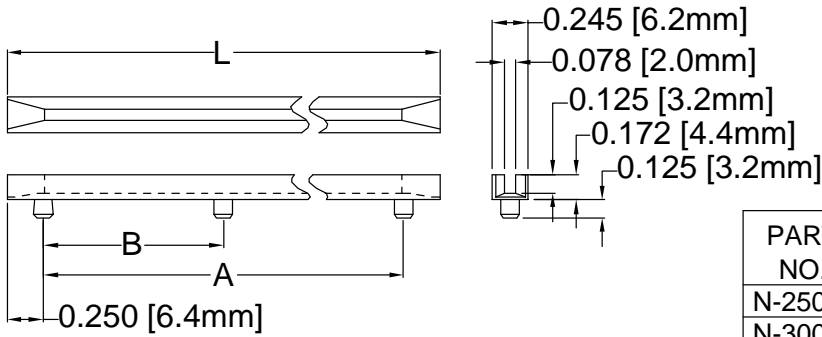

Recommended Mounting Holes

PART NO.	L ±.030 (.76)	A ±.024 (.61)	B ±.016 (.41)
N-250-2	2.5 (63.5)	2.0 (50.8)	--
N-300-2	3.0 (76.2)	2.5 (63.5)	--
N-350-2	3.5 (88.9)	3.0 (76.2)	--
N-400-2	4.0 (101.6)	3.5 (88.9)	--
N-450-2	4.5 (114.3)	4.0 (101.6)	--
N-500-2	5.0 (127.0)	4.5 (114.3)	--
N-550-2	5.5 (139.7)	5.0 (127.0)	--
N-600-2	6.0 (152.4)	5.5 (139.7)	--
N-650-2	6.5 (165.1)	6.0 (152.4)	--
N-700-2	7.0 (177.8)	6.5 (165.1)	--
N-700-3	7.0 (177.8)	6.5 (165.1)	3.25 (82.5)
N-750-2	7.5 (190.5)	7.0 (177.8)	--
N-750-3	7.5 (190.5)	7.0 (177.8)	3.50 (88.9)
N-800-2	8.0 (203.2)	7.5 (190.5)	--
N-800-3	8.0 (203.2)	7.5 (190.5)	3.75 (95.2)
N-850-2	8.5 (215.9)	8.0 (203.2)	--
N-850-3	8.5 (215.9)	8.0 (203.2)	4.00 (101.6)

- 2. MATERIAL: NYLON 6/6, 94V-2, NATURAL. BIVAR MATERIAL CODE 03-NL. BASF ULTRAMID NYLON 6/6 A3K NATURAL.
- 1. GENERAL SPECIFICATIONS: BIVAR MOLDED COMPONENT SPECIFICATION BV00-E101.

STANDARD TOLERANCE (UNLESS OTHERWISE SPECIFIED)		 4 THOMAS, IRVINE, CA. 92618 TEL: (949) 951-8808 FAX: (949) 951-3974			
DECIMALS	ANGULAR				
.X ±.1	X° ± 1°	TITLE: NARROW PRESS-IN CARD GUIDE			
.XX ±.01					
.XXX ±.005		DESIGNED: David Green	DATE: 11/13/02	PART NO: N-XXX-X	REVISION: B
CHECKED: M. Chen		DATE: 11/13/02	CAGE CODE : 32559	SHEET # 1 OF 1	
CAD GENERATED DOCUMENT. DO NOT MEASURE DRAWING.					