

Part Number:

254-PB511-ROX

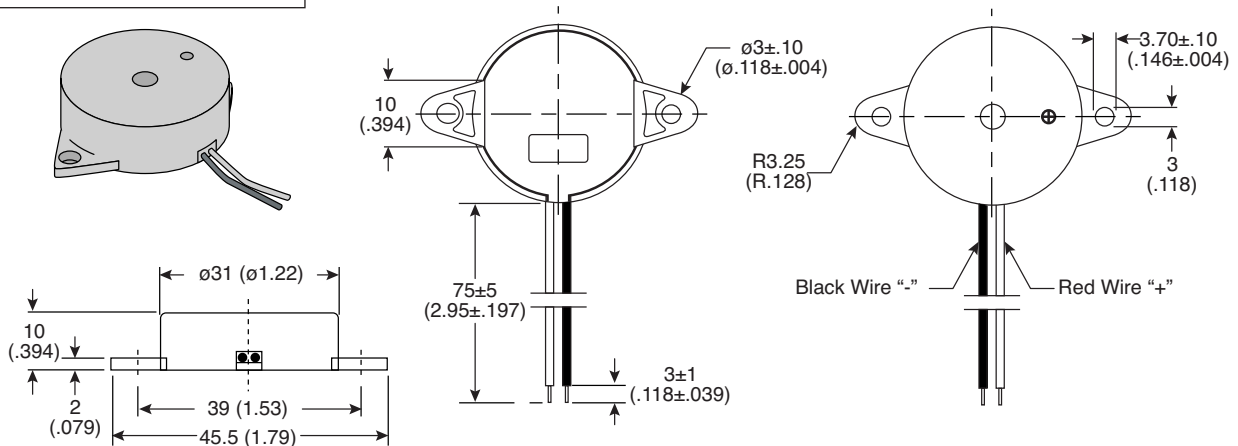

Piezoelectric Buzzer
(Built-In Drive)

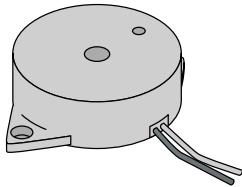
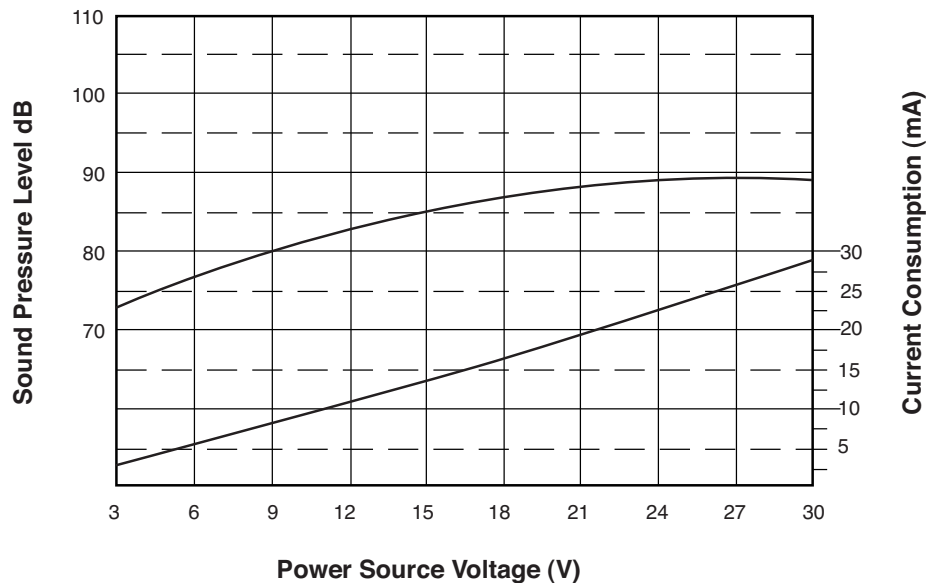

KT-400411

Electrical Specifications:

- Sound Pressure Level: 80dB min./30cm./9VDC
- Oscillating Frequency: 2.5 ± 0.5 KHz
- Current Consumption: 8mA max./9VDC
- Operating Voltage: 3 to 30VDC

Materials:

- Tone: Continuous
- Case: PBT
- Lead Wire: UL1095 28AWG
- Weight: 7 grams

Mechanical Specifications:

- Operating Temperature: -30°C to $+70^{\circ}\text{C}$
- Storage Temperature: -40°C to $+85^{\circ}\text{C}$

Note:

- RoHS compliant by exemption

Available from Mouser Electronics

www.mouser.com

(800) 346-6873

Specifications are subject to change without notice. No liability or warranty implied by this information. Environmental compliance based on producer documentation.