

- NOTES:
- MATERIALS AND FINISHES:
 BODY - BeCu, GOLD PLATING, .000030 (0.8) THICK OVER NICKEL
 CONTACT - BeCu, GOLD PLATING, .000030 (0.8) THICK OVER NICKEL
 INSULATOR - PTFE
 - ELECTRICAL:
 A. IMPEDANCE: 50 OHM
 B. FREQUENCY RANGE: DC - 26.5 GHz
 C. VSWR(RETURN LOSS): 1.2 (20.8 dB), MAX. DC-10GHz
 1.4 (15.6 dB), MAX. 10-18GHz
 1.5 (14 dB), MAX. 18-26.5GHz
 D. DIELECTRIC WITHSTANDING VOLTAGE: 500 VRMS, MIN.
 - PHYSICAL:
 A. DURABILITY: 100 CYCLES MIN.
 B. ENGAGEMENT FORCE: 15 LB [67 N] MAX
 C. DISINGAGEMENT FORCE: 2 LB [9 N] MIN
 E. TEMPERATURE RANGE: -65° C TO 165° C
 - PACKAGING:
 A. QUANTITY: SINGLE PACK
 B. MARKING:
 RNT 9003/05
 AMPHENOL
 SMP-FSBA-145
 DATE CODE
 QTY

SMP-FSBA-145		REVISIONS			
DRAWING NO.	REV	DESCRIPTION	DATE	ECO	APPR
THIRD ANGLE PROJ.	01	PROTOTYPE RELEASE	13-May-02		MAH

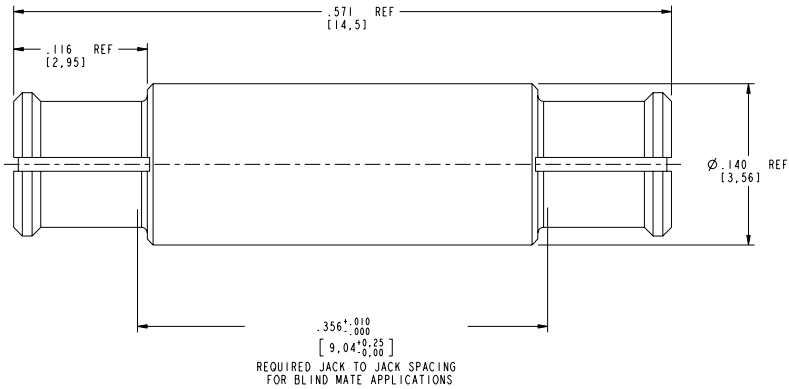

SCALE 4.000

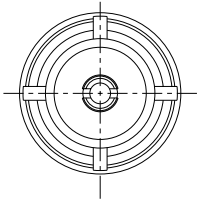

CUSTOMER OUTLINE DRAWING
 ALL OTHER SHEETS ARE FOR INTERNAL USE ONLY

UNLESS OTHERWISE SPECIFIED, DIMENSIONS ARE IN INCHES AND TOLERANCES ARE: 2 PLACE DECIMAL 3 PLACE DECIMAL ANGLES ±.015 (0.381 mm) ±.005 (0.127 mm) ± 1°	MATERIAL	DRAWN M. HOYACK	DATE 13-May-02	TITLE SMP BULLET ADAPTER FEMALE TO FEMALE	Amphenol Amphenol Corporation Communication and Network Products Division Danbury, CT U.S.A. 06810			
	NOTICE - These drawings, specifications, or other data (1) are, and remain the property of Amphenol Corp. (2) must be returned upon request; and (3) are confidential and not to be disclosed to any person other than those to whom they are given by Amphenol Corp. The furnishing of these drawings, specifications, or other data by Amphenol Corp., or to any other person for any purpose is not to be regarded by implication or otherwise in any manner licensing, granting rights or permitting such holder or any other person to manufacture, use or sell any product, process or design, patented or otherwise, that may in any way be related to or disclosed by said drawings, specifications, or other data.	REFERENCE GEN# ASSYF4_SMP 615X-1808-100	ENGINEER M. HOYACK			DATE 13-May-02	SCALE: 12.0:1 SHEET 2 OF 2	
		APPROVED	DATE	CAD FILE 1:\SMP\SMP-FSBA-145	CODE ID 74868	DWG SIZE B	DRAWING NO. SMP-FSBA-145	REV 01