

Part No.: G172-10HA, G172-10HAB, G172-10H, G172-10HB and G172-10LN (Low Noise)
 172mm - Steel Wire Guard

172mm (6.7")

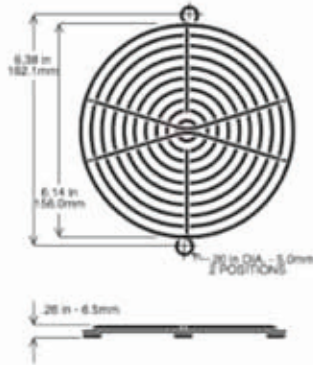

Matching Fan Series:
 OD172,
 OA162S
 OA172,
 OA5920

Part No.:	G172-10HA and G172-10HAB [Black]
Material:	C1008 Steel
Wire Dia (Ring):	1.8mm
Wire Dia (Rib):	2.3mm
Ring Spacing:	Meets 6.35mm plug gauge test
Separation Force:	220 lbs. on welds
Fits:	162 and 172mm fans
Plating:	Bright Nickel Chrome or Black
Options:	Additional plating materials are available by special order.

172mm (6.7")

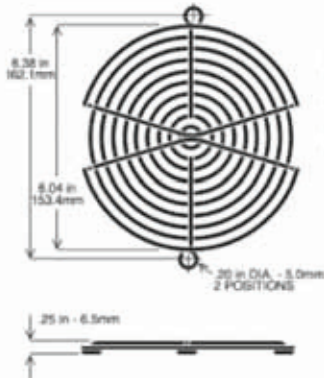

Matching Fan Series:
 OD172,
 OA162-5E
 OA172S,
 OA5920

Part No.:	G172-10H and G172-10HB [Black]
Material:	C1008 Steel
Wire Dia (Ring):	1.8mm
Wire Dia (Rib):	2.3mm
Ring Spacing:	Meets 6.35mm plug gauge test
Separation Force:	220 lbs. on welds
Fits:	162 and 172mm fans
Plating:	Bright Nickel Chrome or Black
Options:	Additional plating materials are available by special order.

172mm (6.7")

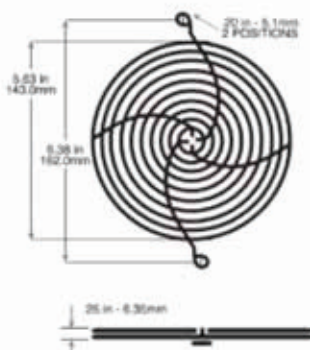

Matching Fan Series:
 OD172,
 OA162-5E
 OA172S,
 OA5920

Aerodynamic design helps to reduce fan noise.

Part No.:	G172-10LN
Material:	C1008 Steel
Wire Dia (Ring):	1.6mm
Wire Dia (Rib):	2.0mm
Ring Spacing:	Meets 6.35mm plug gauge test
Separation Force:	220 lbs. on welds
Fits:	162 and 172mm fans
Plating:	Bright Nickel Chrome
Options:	Additional plating materials are available by special order.