

Drawings and specifications are, and remain our property and must be returned to us. All specifications are not to be disclosed to any persons other than those to whom they are sent. Specifications or other data belonging to us which may be furnished to vendors for production are to be regarded by implication or otherwise as in any manner licensing the holder or any corporation or covering any rights or permission to manufacture, use or sell any patented article that may in any way be related thereto.

ALL BURRS BREAK CORNERS AND SHARP EDGES .005 MAXIMUM UNLESS OTHERWISE SPECIFIED

DO NOT SCALE THIS DRAWING

36250  
DRAWING NUMBER  
ISSUE M

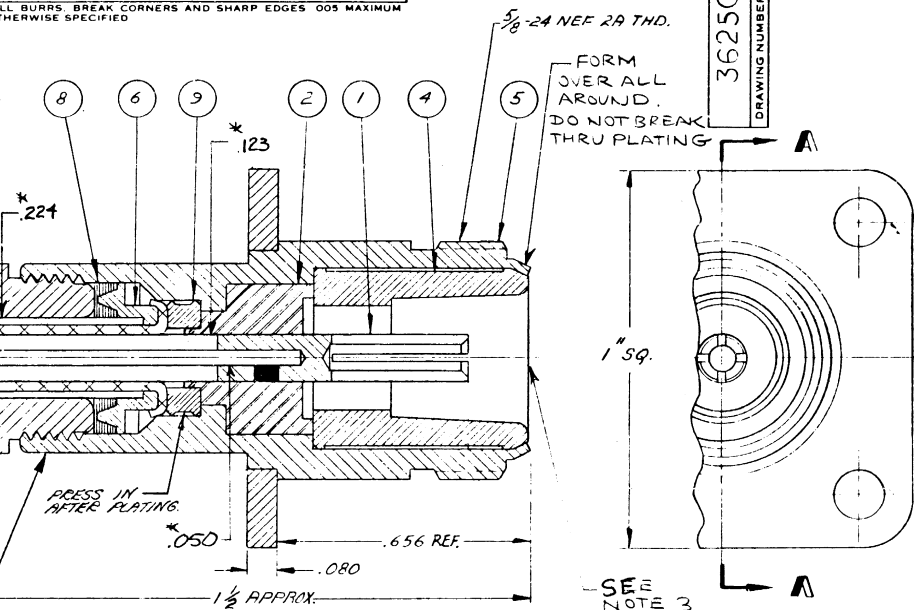

SECTION A-A

"CLAMP" PARTS UG-1095A/U IN 1/16 HIGH EXPRESSED CHARACTERS.

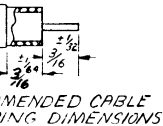

RECOMMENDED CABLE CLAMPING DIMENSIONS

- NOTES:
1. LESS FLANGE SEE DWG 35025
  2. PLATING MUST CONFORM TO SPEC. 349-50360 CONTACT IS SILVER PLATED. ALL OTHER METAL PARTS ARE ASTROPLATED (REF)

REVISIONS					
ZONE	SYM	DESCRIPTION	DATE	ECONO	APPR
	E	REDRAWN GENERAL REVISION	7-12-62	5802	JCS
	F	GEN REV	8-26-63	7879	RTW
	G	IPC TO AMPH. COMP.	8-8-71	T-3	RTW
	H	UPDATED PER EPA 80R125	6-1-69	10586	S.P.
	J	UPDATED PER EPA 80R125 ADDED NOTE E, ITEM 4 WAS 30 ITEM 7 WAS 31-1928	7/16/65	102263	S.P.
	K	CHANGED PLATING TO ASTRO	1-22-75	22607	REP
	L	BUSHING ITEM D WAS 31-1102	1/13/87	34039	WLC
	M	ADDED NOTES 2 THRU 6	7/3/93	39230	DR

NOTES: (CONT)

3. MUST CONFORM TO SPEC. 349-50351, SECTION 911. OMIT REFERENCE TO CONTACT.
4. PACKAGE IN BAG 999-226.
5. \* ASTERISK INDICATES CABLE ENTRY DIMENSIONS.
6. ITEMS 1, 6, 7, AND 8 ARE SHIPPED LOOSE.

QTY	PART NO	DESCRIPTION	FINISH	
1	9	31-2175-2H	CLAMP BUSHING	NOTE 2
1	8	82-1536-5H	CLAMP GASKET	
1	7	31-1228-1H	CLAMP NUT	NOTE 2
1	6	82-1551-3H	BRAND CLAMP	NOTE 2
1	5	82-11950-H	BODY S/A	NOTE 2
1	4	82-718 H	BUSHING	NOTE 2
1	3			
1	2	35-278-4	INSULATOR	
1	1	36256 - F	FEMALE CONTACT	NOTE 2

LIST OF MATERIAL AMPHENOL RF

DRAWN BY D J FEZZULLO 7-12-62		DATE	TITLE		AMPHENOL BORG ELECTRONICS CORP. GENERAL OFFICER DANBURY, CONN. PLANTS AT CHICAGO 38, ILL. WOODSIDE 77, N.Y. DANBURY, CONN.
CHECKED 8/6 8-15-62	DATE	IMPROVED 'N' PANEL JACK FOR RG 58/U (UG-1095A/U)			
ENGINEER P MCGEARY 8-20-62	DATE	CODE IDENTIFICATION		DRAWING SIZE	DRAWING NO
APPROVED WRT 7	DATE 8-20-62	B		36250	M
REFERENCE DRAWING NO REF B 49213	SCALE 4:1	SHEET		OF	

UNLESS OTHERWISE SPECIFIED DIMENSIONS ARE IN INCHES		
TOLERANCE ON FRACTIONS	DECIMALS	ANGLES
+ .010	+ .003	+ .1°
MATERIAL	//	
SPECIFICATION	UG-1095 A/U	
FINISH	SEE LIST OF MAT'L	

OFFICIAL ENG REL  
7870  
(2-27-63)

NEXT ASSY	USED ON
	APPLICATION