

REV.	DATE	DESCRIPTION
NC	06/23/98	INITIAL RELEASE
A	02/24/03	UPDATE DRAWING FORMAT

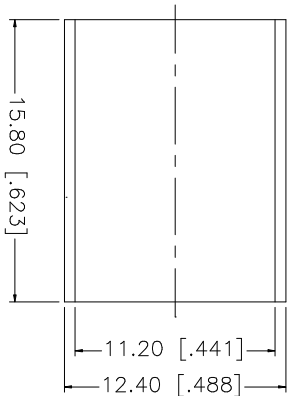
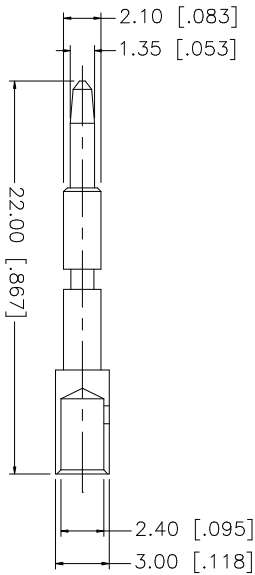
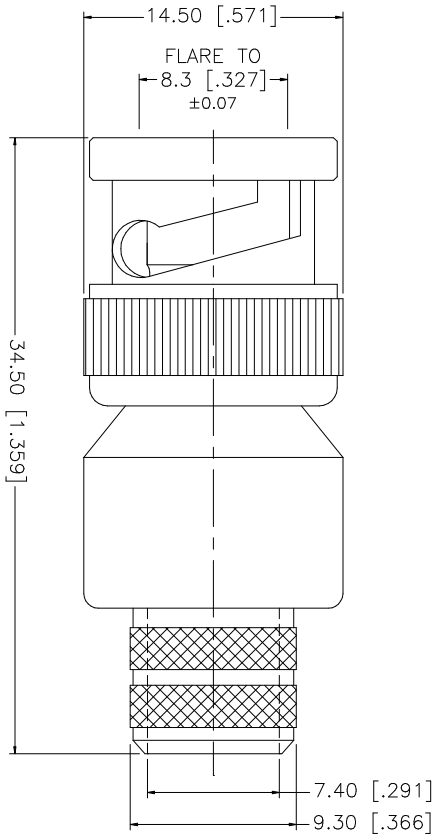
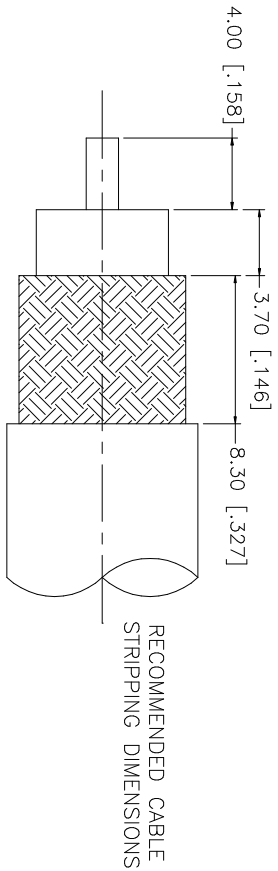

- CRIMP NOTES:
1. CRIMPED FERRULE
HEX CRIMP SIZE .429"
 2. CRIMPED CONTACT PIN
HEX CRIMP SIZE .100"

QTY	FINISH	MATERIAL	DESCRIPTION
1	NICKEL	BRASS	FERRULE
1	GOLD	BRASS	CONTACT PIN
1	NATURAL	TEFLON	INSULATOR
1	NICKEL	BRASS	SHELL/BODY

APPROVALS	DATE	PART DESCRIPTION
DRAWN G.R.S.	07/20/05	BNC CRIMP PLUG (FOR RG-214 CABLE)
CHECKED		
ISSUED		
SHEET 1 OF 1		

UNLESS OTHERWISE SPECIFIED DIMENSIONS ARE IN MILLIMETERS. DIMENSIONS IN [] ARE IN INCHES AND FOR CUSTOMER REFERENCE ONLY. TOLERANCES FOR MILLIMETERS ARE: 0.5 - 8mm ± 0.20mm 8 - 30mm ± 0.40mm 30 - 120mm ± 0.50mm	UNLESS OTHERWISE SPECIFIED DIMENSIONS ARE IN MILLIMETERS. DIMENSIONS IN [] ARE IN INCHES AND FOR CUSTOMER REFERENCE ONLY. TOLERANCES FOR INCHES ARE: .020 - .315 = ± 0.007" .315 - 1.180 = ± 0.015" 1.180 - 4.724 = ± 0.020"
--	--

DO NOT SCALE DRAWING	CAD FILE C:/112/112589.DWG	DWG. NO. 112589.DWG	REV. A	SIZE A	SCALE NA
----------------------	----------------------------	---------------------	--------	--------	----------

Amphenol Connex

BNC CRIMP PLUG
(FOR RG-214 CABLE)

112589