

MATERIAL NO. LOOSE PIECE	ENG. NO.	MATERIAL NO. TAPE MOUNTED	ENG. NO.	STUD SIZE	+0.003 "S"	STOCK THICKNESS
191930132	C-340-10	191930133	C-340-10T	10	.198	.040 (1.02)
191930134	C-340-14	191930135	C-340-14T	1/4	.265	
191930141	C-340-56	191930142	C-340-56T	5/16	.328	
191930137	C-340-38	191930139	C-340-38T	3/8	.390	

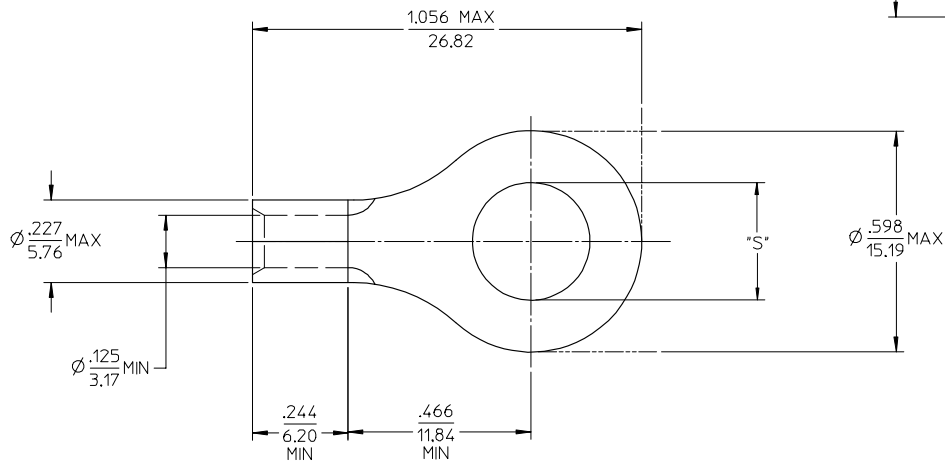

SALES DRAWING

- NOTE(S):  
 1. MATERIAL: COPPER  
 2. PLATING: ELECTROPLATE TIN  
 3. ALL DIMENSIONS IN INCHES/(MM)  
 4. WIRE SIZE: 12-10 AWG  
 4.0-6.0 MM<sup>2</sup>

REVISED/UPDATE TO MK STDS EC NO: ETC2003-0315 DRAWN/CHKD 2003/08/20 CHKD/HEB 2003/08/21 APPR/RODROSS 2003/08/21	QUALITY SYMBOLS	GENERAL TOLERANCES (UNLESS SPECIFIED)	SCALE 4:1	DESIGN UNITS INCH	THIRD ANGLE PROJECTION	REVISE ON CAD ONLY																			
	▽ -0 ▽ -0	<table border="1"> <tr> <th></th> <th>mm</th> <th>INCH</th> </tr> <tr> <td>4 PLACES</td> <td>± .---</td> <td>± .---</td> </tr> <tr> <td>3 PLACES</td> <td>± .---</td> <td>± .005</td> </tr> <tr> <td>2 PLACES</td> <td>± 0.13</td> <td>± .01</td> </tr> <tr> <td>1 PLACE</td> <td>± 0.25</td> <td>± .---</td> </tr> </table>		mm	INCH	4 PLACES	± .---	± .---	3 PLACES	± .---	± .005	2 PLACES	± 0.13	± .01	1 PLACE	± 0.25	± .---	<table border="1"> <tr> <th colspan="2">DIMENSION STYLE</th> </tr> <tr> <td>IN/MM</td> <td></td> </tr> </table>	DIMENSION STYLE		IN/MM		TITLE	RING TONGUE TERMINAL VERSAKRIMP 12-10 AWG	
			mm	INCH																					
		4 PLACES	± .---	± .---																					
3 PLACES	± .---	± .005																							
2 PLACES	± 0.13	± .01																							
1 PLACE	± 0.25	± .---																							
DIMENSION STYLE																									
IN/MM																									
DRAFT WHERE APPLICABLE MUST REMAIN WITHIN DIMENSIONS	<table border="1"> <tr> <td>DRAWN BY</td> <td>DATE</td> </tr> <tr> <td>DLM</td> <td>03/06/13</td> </tr> <tr> <td>CHECKED BY</td> <td>DATE</td> </tr> <tr> <td>HEB</td> <td>03/06/13</td> </tr> <tr> <td>APPROVED BY</td> <td>DATE</td> </tr> <tr> <td>RWD</td> <td>03/06/13</td> </tr> </table>	DRAWN BY	DATE	DLM	03/06/13	CHECKED BY	DATE	HEB	03/06/13	APPROVED BY	DATE	RWD	03/06/13	<table border="1"> <tr> <td>MATERIAL NO.</td> <td>DOCUMENT NO.</td> <td>SHEET NO.</td> </tr> <tr> <td>(SEE CHART)</td> <td>SD-19193-026</td> <td>1 OF 1</td> </tr> </table>	MATERIAL NO.	DOCUMENT NO.	SHEET NO.	(SEE CHART)	SD-19193-026	1 OF 1					
DRAWN BY	DATE																								
DLM	03/06/13																								
CHECKED BY	DATE																								
HEB	03/06/13																								
APPROVED BY	DATE																								
RWD	03/06/13																								
MATERIAL NO.	DOCUMENT NO.	SHEET NO.																							
(SEE CHART)	SD-19193-026	1 OF 1																							
THIS DRAWING CONTAINS INFORMATION THAT IS PROPRIETARY TO MOLEX INCORPORATED AND SHOULD NOT BE USED WITHOUT WRITTEN PERMISSION																									