

MATERIAL NUMBER	ALTERNATE NUMBER	"S"	WIRE RANGE	COLOR	PACKAGING
I90570007	A-521-06	.146/3.70	22-18 AWG	RED	LOOSE PIECE
I90570009	A-521-08	.173/4.39	22-18 AWG	RED	LOOSE PIECE
I90570011	A-521-10	.198/5.02	22-18 AWG	RED	LOOSE PIECE
I90570008	A-521-06T	.146/3.70	22-18 AWG	RED	TAPE
I90570010	A-521-08T	.173/4.39	22-18 AWG	RED	TAPE
I90570012	A-521-10T	.198/5.02	22-18 AWG	RED	TAPE

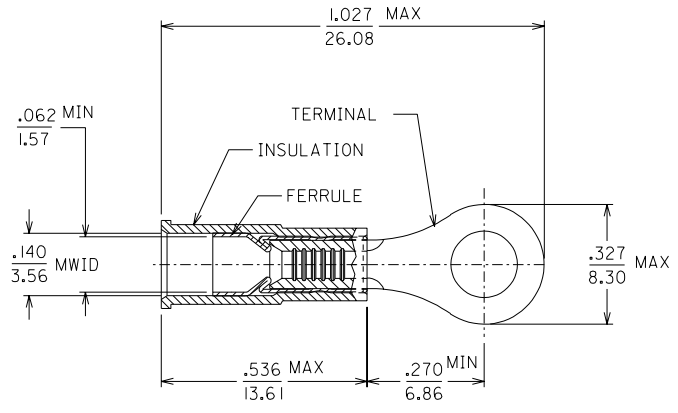
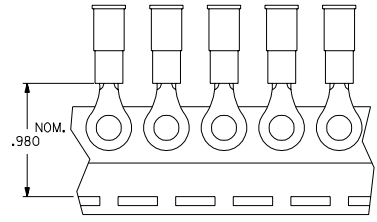

- MATERIAL: TERMINAL: COPPER
.028/.711 THICK
FUNNEL FERRULE: BRASS
PLATING: ELECTRO TIN
INSULATION: NYLON 6/6
COLOR: SEE CHART
- MWID = MAXIMUM WIRE INSULATION DIAMETER
- ALL DIMENSIONS = INCHES / MM

CUSTOMER DRAWING

A	NEW CUST. DWG. ETC2001-0288 01/03/23 EDB
LTR.	REVISIONS

DIMENSIONS SHOWN (METRIC) INCH UNLESS OTHERWISE SPECIFIED TOLERANCES: ANGULAR ± 1/2°		REVISE ONLY ON CAD SYSTEM													
<table border="1"> <thead> <tr> <th></th> <th>INCH</th> <th>METRIC</th> </tr> </thead> <tbody> <tr> <td>3 PLACE</td> <td>± .005</td> <td>± ---</td> </tr> <tr> <td>2 PLACE</td> <td>± .01</td> <td>± 0.13</td> </tr> <tr> <td>1 PLACE</td> <td>± ---</td> <td>± 0.25</td> </tr> </tbody> </table>			INCH	METRIC	3 PLACE	± .005	± ---	2 PLACE	± .01	± 0.13	1 PLACE	± ---	± 0.25	TITLE RING TONGUE TERMINAL AVIKRIMP 500 SERIES	
	INCH	METRIC													
3 PLACE	± .005	± ---													
2 PLACE	± .01	± 0.13													
1 PLACE	± ---	± 0.25													
DRAFT WHERE APPLICABLE MUST REMAIN WITHIN DIMENSIONS		SHEET NO. DATE 1 OF 1 01/03/23													
PART NO. SD-19057-002		DRAWG. NO. SD-19057-002													
DRWG. BY: EDB	CHK'D. BY: HEB	FILE NAME: SD19057002	THIS DRAWING CONTAINS INFORMATION THAT IS PROPRIETARY TO MOLEX-ETC INC. AND SHOULD NOT BE USED WITHOUT WRITTEN PERMISSION.												
APP'D. BY: RWD	SCALE: NO:NE	DDN													
		SEE TABLE	DTV. SIZE: ET B												