

REV.	DATE	DESCRIPTION
A	05/27/03	UPDATE DRAWING FORMAT

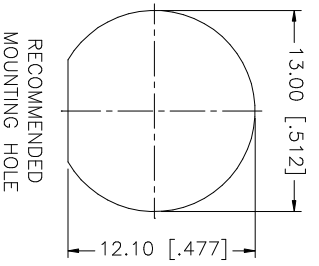
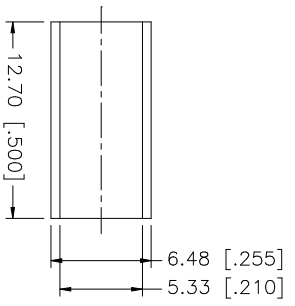
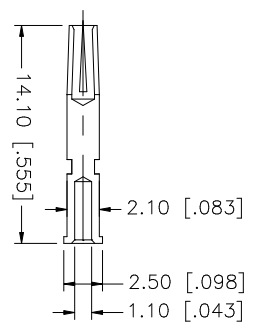
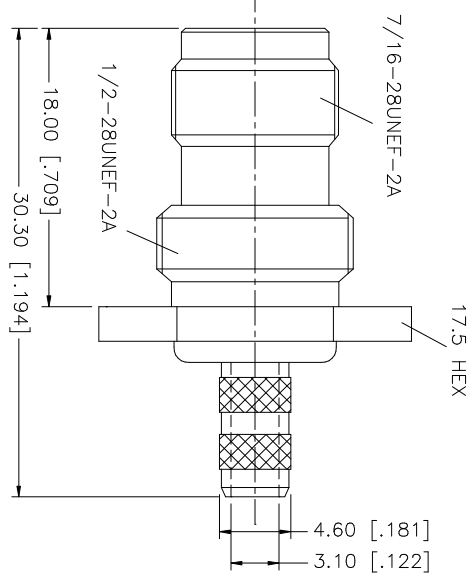
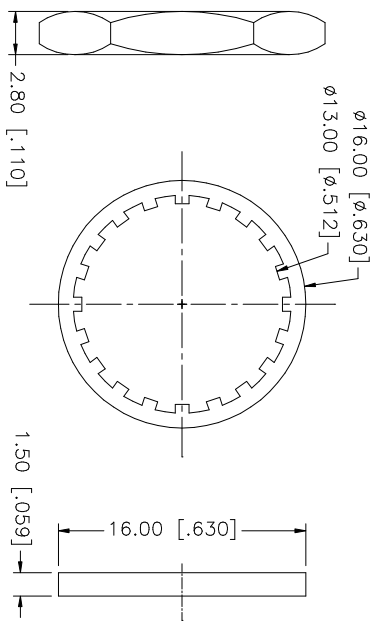
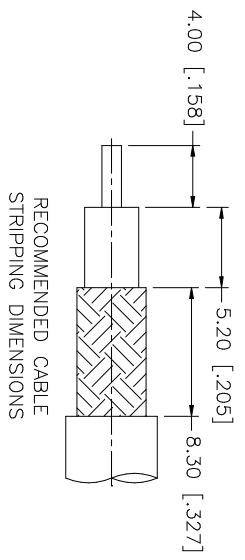

- NOTES:
1. CRIMPED FERRULE HEX CRIMP SIZE .213"
 2. CRIMPED CONTACT PIN HEX CRIMP SIZE .068"
 3. MAX. PANEL THICKNESS = 3.5mm

QTY	FINISH	MATERIAL	DESCRIPTION
1	NICKEL	COPPER	FERRULE
1	NICKEL	RUBBER	GASKET
1	NICKEL	BRASS	HEX NUT
1	NICKEL	BRASS	LOCKWASHER
1	GOLD	PHOS. BRONZE	CONTACT PIN
1	NATURAL	TEFLON	INSULATOR
1	NICKEL	BRASS	BODY

UNLESS OTHERWISE SPECIFIED DIMENSIONS ARE IN MILLIMETERS DIMENSIONS IN [] ARE IN INCHES AND FOR CUSTOMER REFERENCE ONLY.	UNLESS OTHERWISE SPECIFIED TOLERANCES FOR MILLIMETERS ARE:	UNLESS OTHERWISE SPECIFIED TOLERANCES FOR INCHES ARE:
0.5 - 8mm ± 0.20mm	0.5 - 8mm ± 0.20mm	.020 - .315 = ± 0.007"
8 - 30mm ± 0.40mm	8 - 30mm ± 0.40mm	.315 - 1.180 = ± 0.015"
30 - 120mm ± 0.50mm	30 - 120mm ± 0.50mm	1.180 - 4.724 = ± 0.020"

APPROVALS	DATE	CAD FILE
DRAWN G.R.S.	05/27/03	C:/122/122160.DWG
CHECKED		
ISSUED		
SHEET 1 OF 1		

PART NO.	DWG. NO.	REV.	SIZE	SCALE
122160	122160.DWG	A	A	NA

Amphenol Connex

TNC BULKHEAD CRIMP JACK
(FOR RG-58/U, 58C/U CABLE)