

NOTES:

- MATERIALS OF CONSTRUCTION:
 BODIES (2) = BRASS, SILVER PLATED
 CONTACT = BERYLLIUM COPPER, SILVER PLATED
 LOCKWASHER = PHOSPHOR BRONZE, SILVER PLATED
 INSULATORS (2) = TEFLON

31-4890-1		REVISIONS			
DRAWING NO.	REV	DESCRIPTION	DATE	ECO	APPR
THIRD ANGLE PROJ.	--	RELEASE TO MFG.			
AM	SEE SHEET 1		1/4/01	43594	CPM

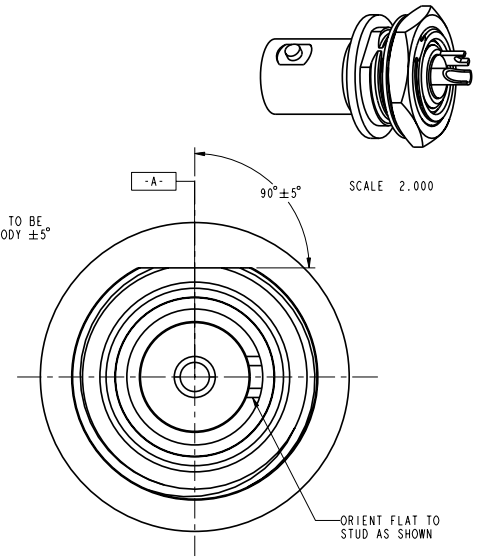
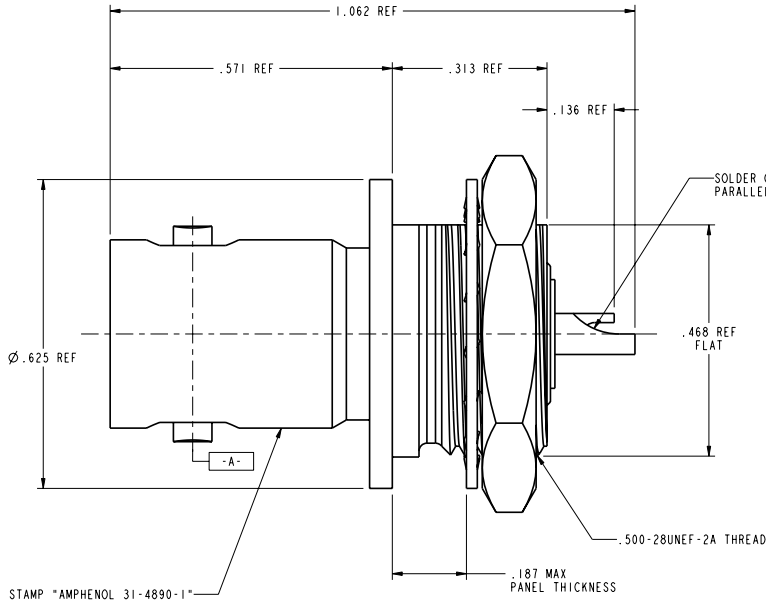

CUSTOMER OUTLINE DRAWING
 ALL OTHER SHEETS ARE FOR INTERNAL USE ONLY

UNLESS OTHERWISE SPECIFIED, DIMENSIONS ARE IN INCHES AND TOLERANCES ARE: 2 PLACE DECIMAL ±.015 (0.381 mm) 3 PLACE DECIMAL ±.005 (0.127 mm) ANGLES ± 1°	MATERIAL	DRAWN C. McGRATH	DATE 05-Dec-00	TITLE BNC ISOLATED BULKHEAD RECEPTACLE	Amphenol Amphenol Corporation Communication and Network Products Division Danbury, CT U.S.A. 06810 SCALE: 5.0:1 SHEET 2 OF 2	
	NOTICE - These drawings, specifications, or other data (1) are, and remain the property of Amphenol Corp. (2) must be returned upon request; and (3) are confidential and not to be disclosed to any person other than those to whom they are given by Amphenol Corp. The furnishing of these drawings, specifications, or other data by Amphenol Corp., or to any other person to anyone for any purpose is not to be regarded by implication or otherwise in any manner licensing, granting rights or permitting such holder or any other person to manufacture, use or sell any product, process or design, patented or otherwise, that may in any way be related to or disclosed by said drawings, specifications, or other data.	REFERENCE GEN# ASSYF17.BNC	ENGINEER O. BARTHELMES	DATE 05-Dec-00		APPROVED O. BARTHELMES
		CAD FILE 1:VBNC\31-4890-1	CODE ID 74868	DWG SIZE B	DRAWING NO. 31-4890-1	REV AM