

NOTES:

- MATERIALS OF CONSTRUCTION:
 BODY & BARREL = BRASS, GOLD PLATING
 FERRULE = COPPER, NICKEL PLATING
 CONTACT = BeCu, GOLD PLATING
 NUT = BRASS, NICKEL PLATING
 INSULATOR = PTFE
- CRIMP WITH AMPHENOL TOOL 227-944 (M22520/5-01) AND DIE SET 227-1221-03, CAVITY 'A' (M22520/5-03, CLOSURE 'A'); OR WITH AMPHENOL COMMERCIAL TOOL CTL-1 (.128 HEX).

102-913-06		REVISIONS			
DRAWING NO.	REV	DESCRIPTION	DATE	ECO	APPR
THIRD ANGLE PROJ.	A	RELEASE TO MFG.	1/21/00	43230	CPM

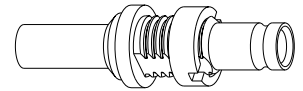
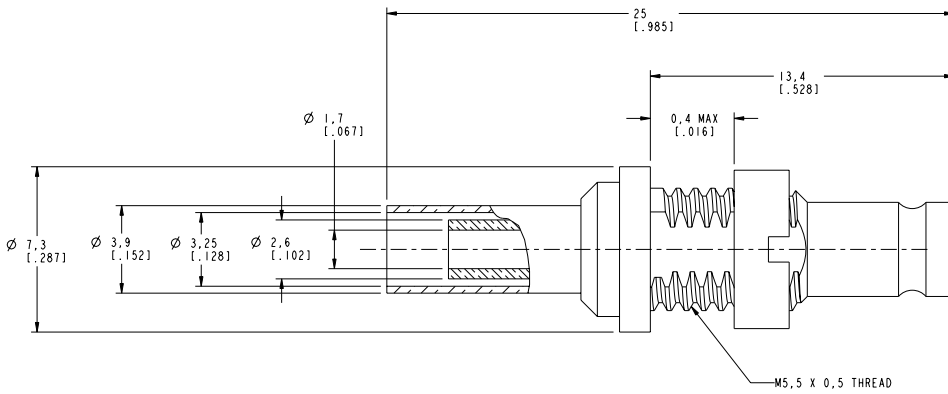

SCALE 3.000

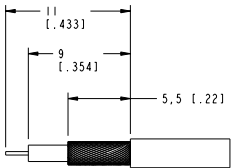

RECOMMENDED
CABLE STRIPPING DIM'S.
SCALE 3.000

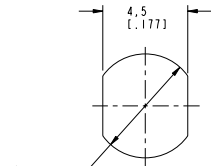

RECOMMENDED
MOUNTING HOLE DIM'S.
SCALE 5.000

CUSTOMER OUTLINE DRAWING
ALL OTHER SHEETS ARE FOR INTERNAL USE ONLY

UNLESS OTHERWISE SPECIFIED, DIMENSIONS ARE IN INCHES AND TOLERANCES ARE: 0.5 - 6mm ±0.2mm 6 - 30mm ±0.4mm 30 - 120mm ±0.6mm	MATERIAL	DRAWN C. McGRATH	DATE 12-Jan-00	TITLE 1.0/2.3 JACK FOR RG 316 CABLE	Amphenol Amphenol Corporation Communication and Network Products Division Danbury, CT U.S.A. 06810
	REFERENCE GEN# 102-913-06.ASSM	ENGINEER T. AUBIN	DATE 12-Jan-00		
NOTICE - These drawings, specifications, or other data (1) are, and remain the property of Amphenol Corp. (2) must be returned upon request; and (3) are confidential and not to be disclosed to any person other than those to whom they are given by Amphenol Corp. The furnishing of these drawings, specifications, or other data by Amphenol Corp., or to any other person for any purpose is not to be regarded by implication or otherwise in any manner licensing, granting rights or permitting such holder or any other person to manufacture, use or sell any product, process or design, patented or otherwise, that may in any way be related to or disclosed by said drawings, specifications, or other data.		APPROVED T. AUBIN	DATE 19-Jan-00	SCALE: 6.0:1	SHEET 2 OF 2
		CAD FILE I:\1023\102-913-06	CODE ID 74868	DWG SIZE B	DRAWING NO. 102-913-06