

PART NUMBER	ITEM ① BODY	ITEM ② CONTACT	ITEM ③ INSULATOR	ITEM ④ HEX NUT	ITEM ⑤ RETENTION SPRING	ITEM ⑥ END CAP	ITEM ⑦ GASKET
142-DB94-101	BRASS GOLD PL .00001 MIN OVER NICKEL PL .00005 MIN OVER COPPER PL .00005 MIN	BRASS GOLD PL .00005 MIN OVER NICKEL PL .00005 MIN OVER COPPER PL .00005 MIN	TEFLON	BRASS GOLD PL .00001 MIN OVER NICKEL PL .00005 MIN OVER COPPER PL .00005 MIN	BERYLLIUM COPPER UNPLATED	BRASS GOLD PL .00001 MIN OVER NICKEL PL .00005 MIN OVER COPPER PL .00005 MIN	NONE
142-DB94-103	BRASS GOLD PL .00001 MIN OVER NICKEL PL .00005 MIN OVER COPPER PL .00005 MIN	BRASS GOLD PL .00005 MIN OVER NICKEL PL .00005 MIN OVER COPPER PL .00005 MIN	TEFLON	BRASS GOLD PL .00001 MIN OVER NICKEL PL .00005 MIN OVER COPPER PL .00005 MIN	BERYLLIUM COPPER UNPLATED	BRASS GOLD PL .00001 MIN OVER NICKEL PL .00005 MIN OVER COPPER PL .00005 MIN	SILICONE RUBBER
142-DB94-106	BRASS NICKEL PL .0001 MIN OVER COPPER PL .00005 MIN	BRASS GOLD PL .00005 MIN OVER NICKEL PL .00005 MIN OVER COPPER PL .00005 MIN	TEFLON	BRASS NICKEL PL .0001 MIN OVER COPPER PL .00005 MIN	BERYLLIUM COPPER UNPLATED	BRASS NICKEL PL .0001 MIN OVER COPPER PL .00005 MIN	NONE

DRAWING NO. C - 142-0694 - 101/110	
0 REVISIONS	
ENGINEERING RELEASE	
1	6-27-97 R H S T T 107-16-97 ECN 44774
ADDED: P/N 142-DB94-103, ITEM 7	
* REVISION NUMBER FOLLOWED BY AN ALPHA *	
* CHARACTER INDICATES DRAWING CLASS *	
* CATION OR PART NUMBER ADDITION ONLY *	
1a	10-26-99 R H S T T 11-4-99 ECN 46779
UPDATED TO 1 PC BODY DESIGN	
2	1-13-00 R H S T T ECN 46788

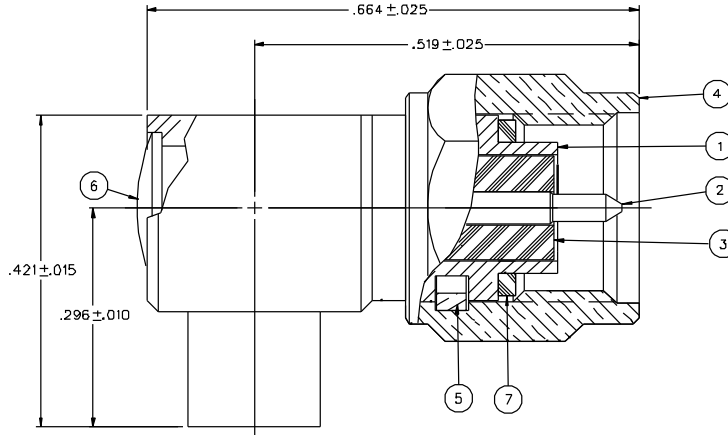

NOTES:

1. SPECIFICATIONS:

IMPEDANCE: 50 OHMS
 FREQUENCY RANGE: 0-18 GHZ
 VSWR: 1.15-0.15F MAX (0-12.4 GHZ) (F IN GHZ)
 1.15-.04F MAX (12.4-18 GHZ) (F IN GHZ)
 WORKING VOLTAGE: 500 VRMS MAX AT SEA LEVEL
 DIELECTRIC WITHSTANDING VOLTAGE: 1500 VRMS MIN AT SEA LEVEL
 INSULATION RESISTANCE: 5000 MEGOHM MIN
 CONTACT RESISTANCE:
 CENTER CONTACT - INITIAL 4.0 MILLIOHM MAX, AFTER ENVIRONMENTAL 6.0 MILLIOHM MAX
 OUTER CONDUCTOR - INITIAL 2.0 MILLIOHM MAX AFTER ENVIRONMENTAL NOT APPLICABLE
 BODY TO CABLE - 0.5 MILLIOHM MAX (GOLD PLATED), 5.0 MILLIOHM MAX (NICKEL PLATED)
 CORONA LEVEL: 375 VOLTS MIN AT 70,000 FEET
 INSERTION LOSS: .05V/F (F IN GHZ) AT 10 GHZ
 RF LEAKAGE: -90 DB MIN AT 2.5 GHZ
 RF HIGH POTENTIAL WITHSTANDING VOLTAGE: 1000 VRMS MIN AT 4 AND 7 MHZ

MECHANICAL:

ENGAGE/DISENGAGE TORQUE: 2 INCH-POUNDS MAX
 MATING TORQUE: 7-10 INCH POUNDS
 COUPLING PROOF TORQUE: 15 INCH-POUNDS MIN
 COUPLING NUT RETENTION: 60 LBS MIN
 CONTACT RETENTION: 6 LBS MIN
 CABLE ACCEPTABILITY: RG 402/U
 CABLE HEX CRIMP SIZE: NOT APPLICABLE
 CABLE RETENTION: 60 LBS MIN AXIAL FORCE
 DURABILITY: 500 CYCLES MIN
 ENVIRONMENTAL:

(MEETS OR EXCEEDS THE APPLICABLE PARAGRAPH OF MIL-C-39012)
 THERMAL SHOCK: MIL-STD-202, METHOD 107, CONDITION B, EXCEPT -115 DEG C HIGH TEMP
 OPERATING TEMPERATURE: -65 DEG C TO 165 DEG C
 CORROSION: MIL-STD-202, METHOD 101, CONDITION B
 SHOCK: MIL-STD-202, METHOD 213, CONDITION I
 VIBRATION: MIL-STD-202, METHOD 204, CONDITION D
 MOISTURE RESISTANCE: MIL-STD-202, METHOD 106

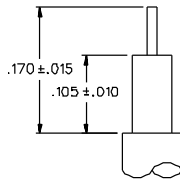

CABLE STRIP DIMENSIONS

CUSTOMER DRAWING

THIS DRAWING TO BE INTERPRETED PER ANS Y 14.5M - 1982

"μSTATION"

COMPANY CONFIDENTIAL

TOLERANCE UNLESS OTHERWISE SPECIFIED	DRAWN BY SWC	DATE 4-7-97	299 Johnson Ave. P.O. Box 1732 Waseca, MN 56093-0832
DECIMALS _____ mm	CHECKED BY SWC	DATE 7-7-97	
.XXX _____	APPROVED BY TAK	DATE 7-7-97	TITLE PLUG ASSEMBLY, RA CABLED SMA, RG 402
MATL _____	APPROVED BY RJE	DATE 7-7-97	CODE NO. C - 142-0694 - 101/110
FINISH _____	RELEASE DATE	7-16-97	DRAWING NO. C - 142-0694 - 101/110
SCALE 10:1 U/M INCH SHEET 2 OF 2			