

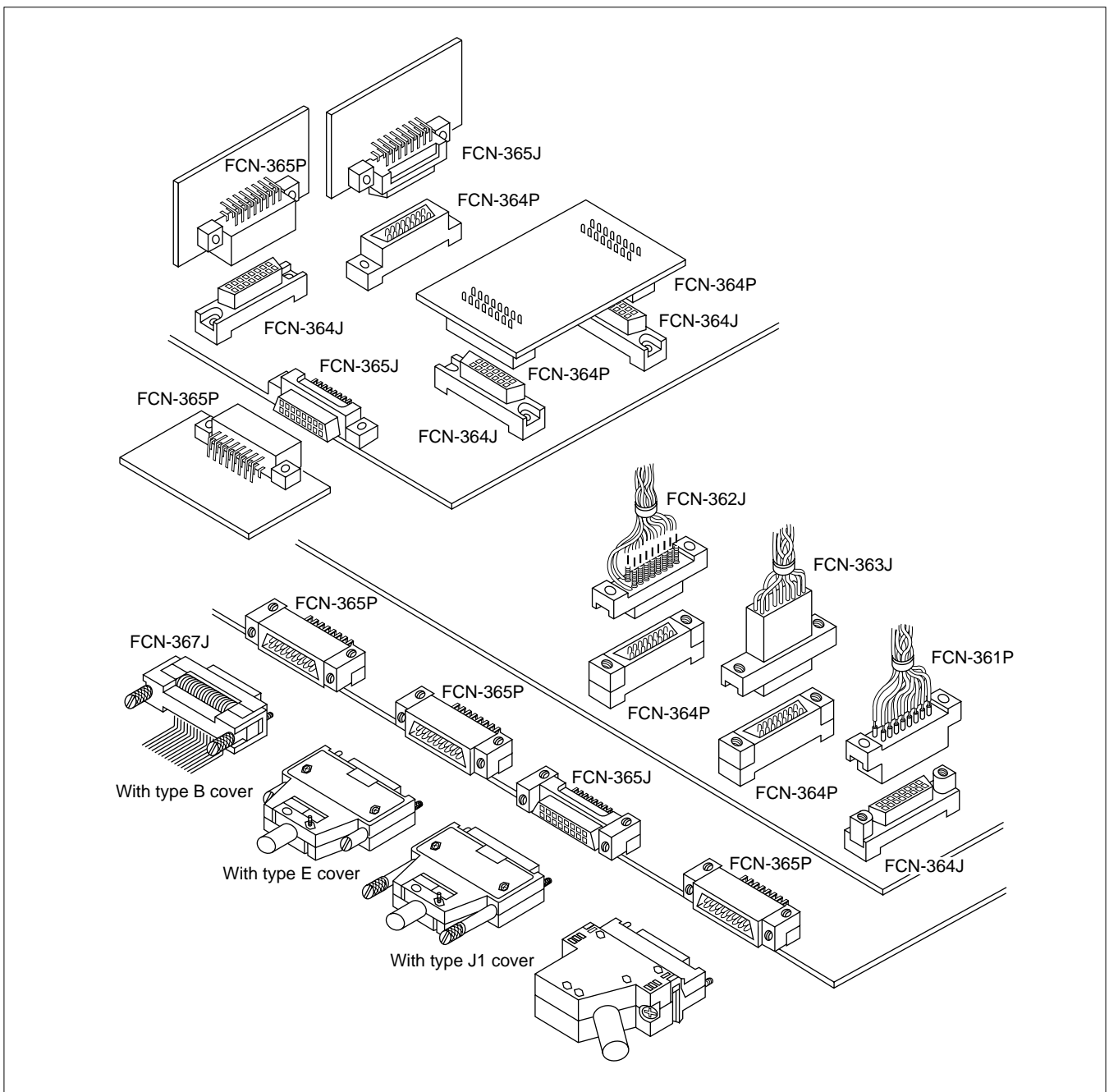

RECTANGULAR CONNECTORS

FCN360 Series



Terms in Selection Table (Example)

| | | | | |
|-----------------------|--|---|--------------------|--------------------|
| Model | | 700 series | | |
| Appearance | |  | | |
| Structure | Contact pitch | 2.54 × 2.54 | | |
| | Number of contacts | 10, 14, 16, 20, 26, 30, 34, 40, 50, 60 | | |
| | Pin type | Solder eyelet (tail shape) | — | |
| | | Wire-wrapping (post cross section) | P | □ 0.64 |
| | | | J | — |
| | | Crimping (applicable AWG No.) | — | |
| | | Straight, throughhole (PC board hole dimensions) | φ 0.8, 2.54 × 2.54 | |
| | | Right-angle, throughhole (PC board hole dimensions) | P | φ 0.8, 2.54 × 2.54 |
| | | | J | — |
| | IDC (applicable AWG No.) | P | #28, Flat cable | |
| J | #28, Flat cable | | | |
| Plating | Gold | ○ | | |
| | Silver | — | | |
| | Tin | ○ | | |
| Specification | Operating temperature range | -55°C to +105°C | | |
| | Current rating | DC 1 A | | |
| | Voltage rating | AC 250 V | | |
| | Contact resistance | 20 mΩ max. (DC 6 V, 0.1 A) | | |
| | Insulation resistance (DC 500 V) | 1,000MΩ min. | | |
| | Dielectric withstanding voltage (for 1 minute) | AC 500 V | | |
| | Insulation material cleaning with Chlorothene | Polyester cleaning possible | | |
| Part number (example) | FCN-705P050-AU/M FCN-707J050-AU/B | | | |
| Remarks | EMI protection cover provided | | | |

- **Contact pitch**
Denotes a pitch between adjacent contacts or pitch between rows.
2.54 mm (0.100 in.) (pitch between adjacent contacts) x 2.54 mm (0.100 in.) (pitch between rows)
- **Number of contacts**
Denotes the numbers of contacts of available connectors.
- **Connection type**
Denotes the connection type of the cable or PC board connection section.
- **Plating**
Denotes the contact plating specification.
- **Specifications**
- **Operating temperature range**
The connector can be used within the specified temperature range.
- **Current rating**
Maximum current that can flow through one connector pin
- **Voltage rating**
Maximum voltage that can be applied to a connector
- **Contact resistance**
Resistance observed at the contact part when 0.3 A (or 0.1 A) flows at 6 VDC with the connectors mated
- **Insulation resistance**
Resistance to the leakage current flowing through the insulator (inside or surface of the insulator) when 500 VDC is applied across adjacent pins of a connector
- **Dielectric withstanding voltage**
Applying the indicated voltage across adjacent pins of a connector for one minute does not cause any abnormality (damage or cracks in insulator).
- **Insulating material, cleaning with chlorothene**
Denotes the insulating material used, and indicates whether the insulating material can be cleaned with chlorothene.
- **Part number**
Some part numbers are indicated as examples.

Rectangular Connectors

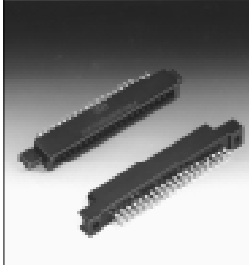
| | | | | |
|---------------------------|--|---|---|-----------------|
| Model | | 360 series | | |
| Appearance | |  | | |
| Structure | Contact pitch | 2.54 × 2.54 | | |
| | Number of contacts | 8, 16, 24, 32, 40, 48, 56, 64 | | |
| | Pin type | Solder eyelet (tail shape) | P | 1.8 × 0.7 |
| | | | J | 1.8 × 0.7 |
| | Wire-wrapping (post cross section) | Diagonal 0.71 mm (0.028 in.) | | |
| | Crimping (applicable AWG No.) | | P | — |
| | | | J | AWG #22 to #28 |
| | | Straight, through hole (PC board hole dimensions) | P | φ1, 2.54 × 2.54 |
| | | | J | φ1, 2.54 × 2.54 |
| | | Right-angle, through hole (PC board hole dimensions) | P | φ1, 2.54 × 2.54 |
| | J | φ1, 2.54 × 2.54 | | |
| IDC (applicable AWG No.) | P | — | | |
| | J | #28, Flat cable | | |
| Plating | Gold | ○ | | |
| | Silver | ○ | | |
| | Tin | — | | |
| Specification | Operating temperature range | -55°C to +85°C | | |
| | Current rating | DC 3 A (IDC type: 1A) | | |
| | Voltage rating | AC 250 V | | |
| | Contact resistance | 15 mΩ max. (DC 6 V, 0.3 A) | | |
| | Insulation resistance (DC 500 V) | 1,000 MΩ min. | | |
| | Dielectric withstanding voltage (for 1 minute) | AC 500 V | | |
| | Insulating material | Polyester PC (363J) | | |
| Part number (example) | | FCN-361P024-AU | | |
| Remarks | | Cable cover provided | | |

NOTES



RECTANGULAR CONNECTORS

FCN-360 SERIES

■ FEATURES

- Many applications
Various connectors are available for connection by means of soldering, wire wrapping, crimping, PC board mounting, and insulation displacement connection (IDC). The user can choose a plug and jack combination that best meet each application.
- Small size for high-density mounting
The connectors are small with a contact and terminal pitch of 2.54 mm (0.100 in.) between pins and between rows and are thus well suited for high-density mounting.
- Sturdy shell guide
Sturdy shell guides are used to prevent mismatching and to protect the pins.
- Excellent cost performance
Streamlined design and automated manufacturing, including use of partial solder plating, provide excellent cost performance.

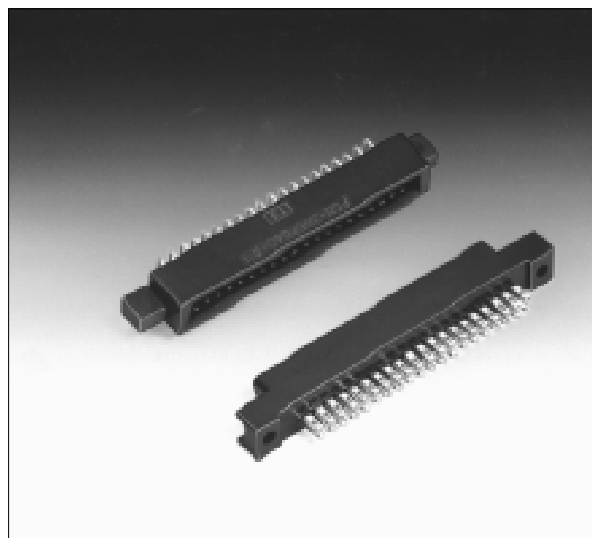

■ SPECIFICATIONS

| Item | | Specification |
|---------------------------------|---------------|---|
| Operating temperature range | | -55°C to +85°C |
| Current Rating | | DC 3 A (IDC type: 1 A) |
| Voltage Rating | | AC 250 V |
| Contact resistance | | 15 mΩ max. (DC 6 V, 0.3 A) |
| Insulation resistance | | 1000 MΩ min. (DC 500 V) |
| Dielectric withstanding voltage | | AC 500 V for 1 minute |
| Insertion force | | 2.5 kg max. (8 contacts), 20 kg max. (64 contacts) |
| Withdrawal force | | 0.3 kg min. (8 contacts), 2.3 kg min. (64 contacts) |
| Applicable wire | Soldering | φ0.60 mm (0.024 in.) max, AWG #23 or less |
| | Wire-wrapping | φ0.32 mm (0.013 in.) to φ0.26 mm (0.010 in.), AWG #28 to #30 |
| | Crimping | Standard contacts φ0.51 mm (0.020 in.) to φ0.32 mm (0.013 in.), AWG #24 to #28, insulator φ1.2 mm (0.047 in.) max. Contacts for thick wires φ0.64 mm (0.025 in.) to φ0.32 mm (0.013 in.), AWG #22 to #28, insulator φ1.7 (0.067 in.) max. |
| | IDC | Flat cable 1.27 mm (0.050 in.) pitch, AWG #28 (stranded wire), AWG #30 (solid wire) |
| Applicable PC board | | 1.6 mm (0.063 in.) standard thick |

■ MATERIALS

| Item | Material |
|-----------|------------------------------|
| Insulator | Polyester (363J: PC94V-2) |
| Conductor | Copper alloy |
| Plating | Gold plating, silver plating |

■ PART NUMBER

FCN-36 7 J 048-AU / H

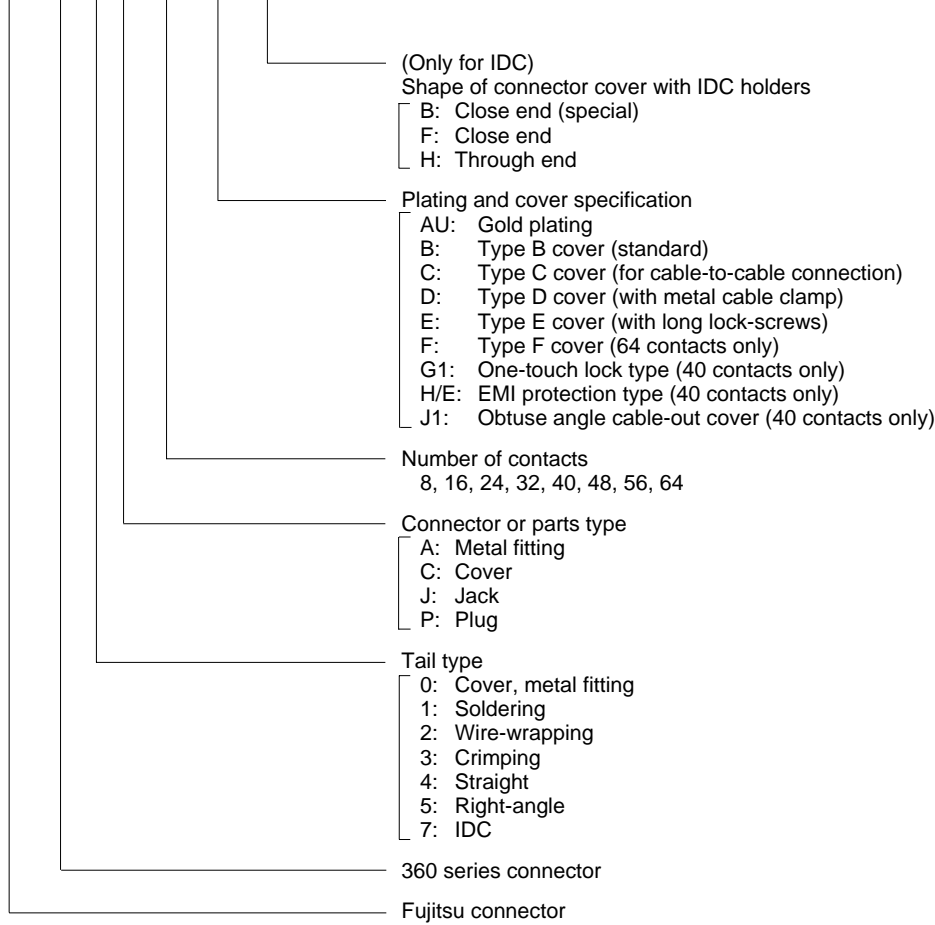

■ APPLICATION EXAMPLE

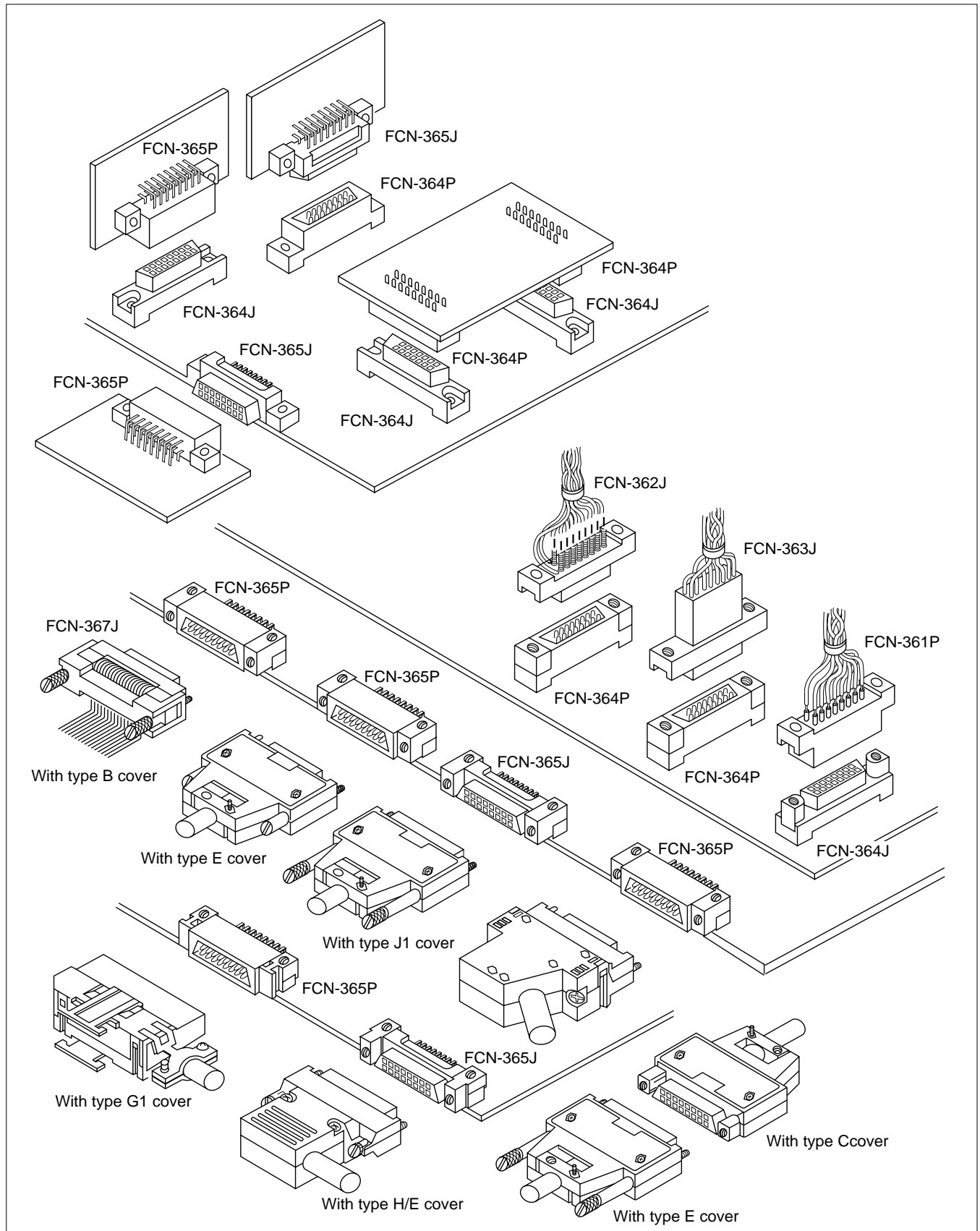

SOLDERING TYPE (PLUG)

■ DIMENSIONS

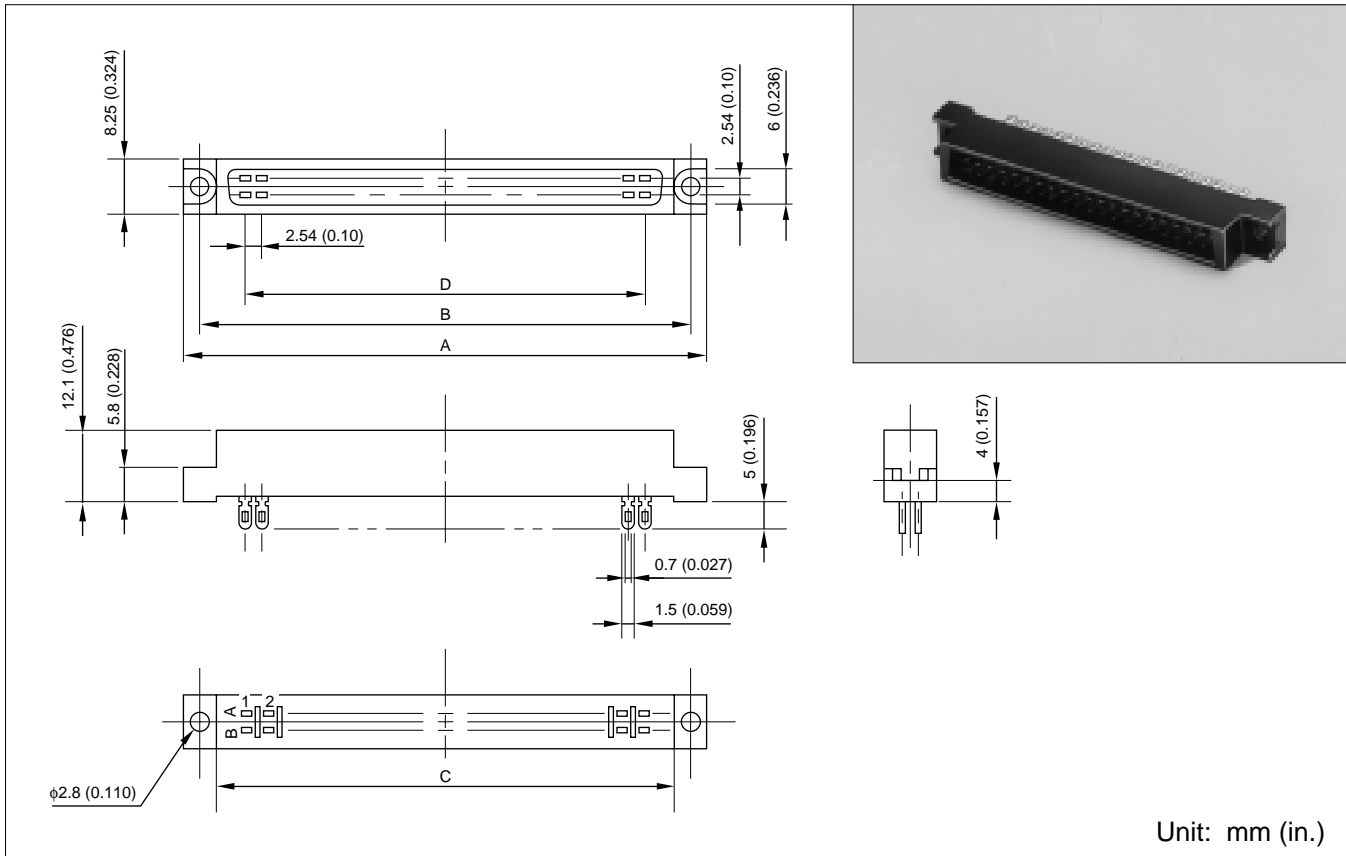

■ MOUNTING HOLE LAYOUT

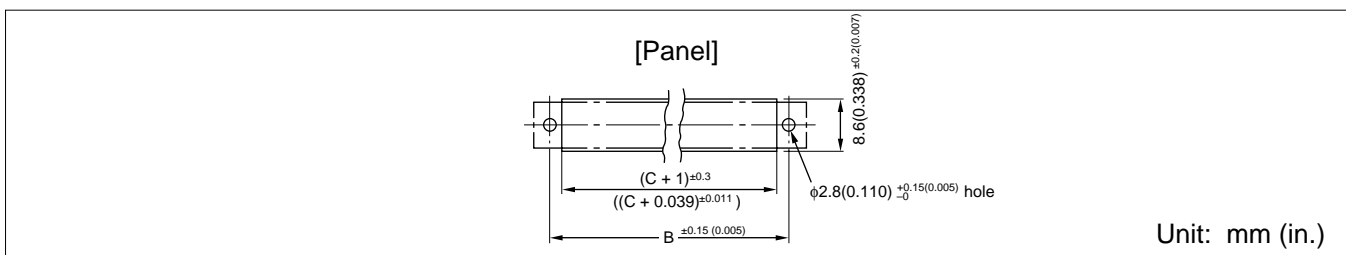

■ PART NUMBERS AND DIMENSIONS

| Number of contacts | Part number | Dimensions: mm (in.) | | | |
|--------------------|----------------|----------------------|---------------|---------------|-------------|
| | | A | B | C | D |
| 8 | FCN-361P008-AU | 28.84 (1.135) | 23.34 (0.918) | 17.84 (0.702) | 7.62 (0.3) |
| 16 | FCN-361P016-AU | 39.0 (1.535) | 33.5 (1.318) | 28.0 (1.102) | 17.78 (0.7) |
| 24 | FCN-361P024-AU | 49.16 (1.935) | 43.66 (1.718) | 38.16 (1.502) | 27.94 (1.1) |
| 32 | FCN-361P032-AU | 59.32 (2.335) | 53.82 (2.118) | 48.32 (1.902) | 38.1 (1.5) |
| 40 | FCN-361P040-AU | 69.48 (2.735) | 63.98 (2.518) | 58.48 (2.302) | 48.26 (1.9) |
| 48 | FCN-361P048-AU | 79.64 (3.135) | 74.14 (2.918) | 68.64 (2.702) | 58.42 (2.3) |
| 56 | FCN-361P056-AU | 89.8 (3.535) | 84.3 (3.318) | 78.8 (3.102) | 68.58 (2.7) |
| 64 | FCN-361P064-AU | 99.96 (3.935) | 94.46 (3.718) | 88.96 (3.502) | 78.74 (3.1) |

FCN-360 Series

SOLDERING TYPE (JACK)

■ DIMENSIONS

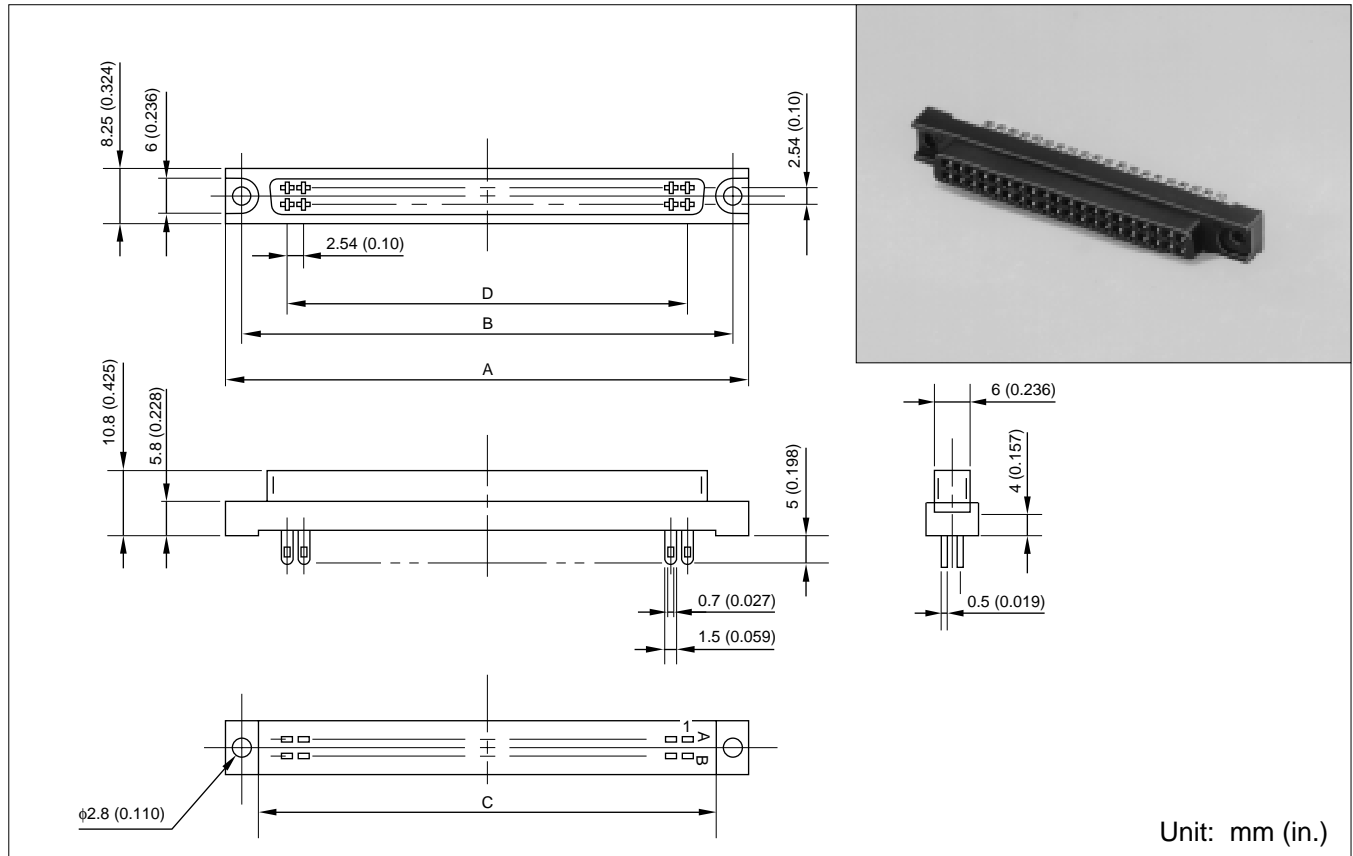

■ BOARD MOUNTING HOLE LAYOUT

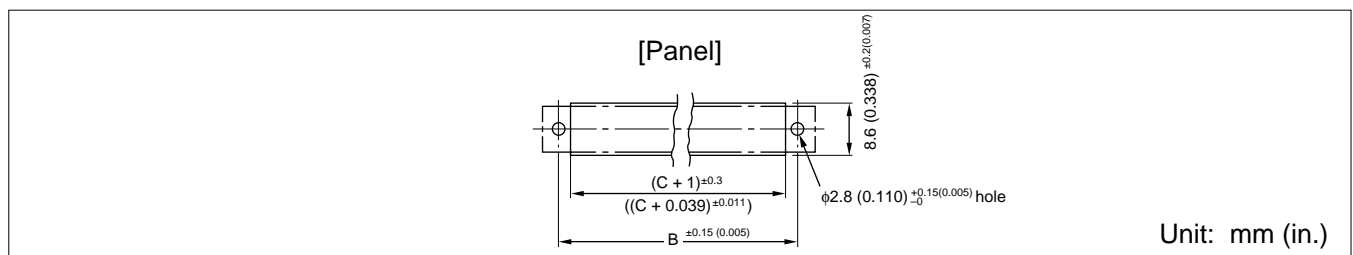

■ PART NUMBERS AND DIMENSIONS

| Number of contacts | Part number | Dimensions: mm (in.) | | | |
|--------------------|----------------|----------------------|---------------|---------------|-------------|
| | | A | B | C | D |
| 8 | FCN-361J008-AU | 28.84 (1.135) | 23.34 (0.918) | 17.84 (0.702) | 7.62 (0.3) |
| 16 | FCN-361J016-AU | 39.0 (1.535) | 33.5 (1.318) | 28.0 (1.102) | 17.78 (0.7) |
| 24 | FCN-361J024-AU | 49.16 (1.935) | 43.66 (1.718) | 38.16 (1.502) | 27.94 (1.1) |
| 32 | FCN-361J032-AU | 59.32 (2.335) | 53.82 (2.118) | 48.32 (1.902) | 38.1 (1.5) |
| 40 | FCN-361J040-AU | 69.48 (2.735) | 63.98 (2.518) | 58.48 (2.302) | 48.26 (1.9) |
| 48 | FCN-361J048-AU | 79.64 (3.135) | 74.14 (2.918) | 68.64 (2.702) | 58.42 (2.3) |
| 56 | FCN-361J056-AU | 89.8 (3.535) | 84.3 (3.318) | 78.8 (3.102) | 68.58 (2.7) |
| 64 | FCN-361J064-AU | 99.96 (3.935) | 94.46 (3.718) | 88.96 (3.502) | 78.74 (3.1) |

FCN-360 Series

WIRE-WRAP TYPE (PLUG)

■ DIMENSIONS

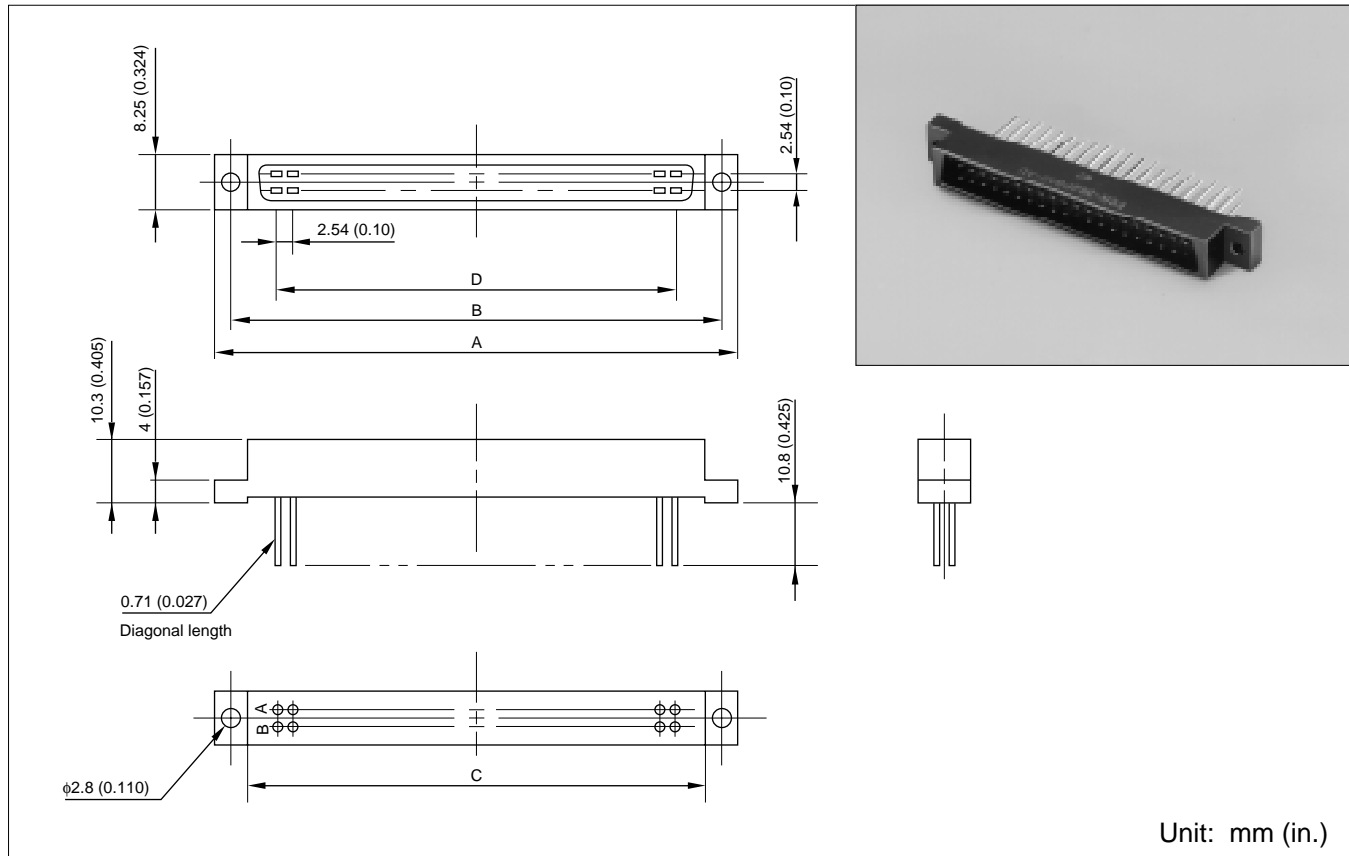

■ MOUNTING HOLE LAYOUT

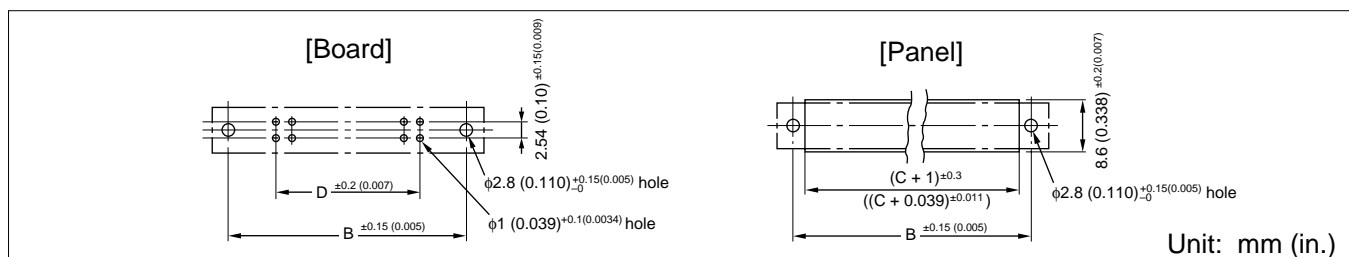

■ PART NUMBERS AND DIMENSIONS

| Number of contacts | Part number | Dimensions: mm (in.) | | | |
|--------------------|----------------|----------------------|---------------|---------------|-------------|
| | | A | B | C | D |
| 8 | FCN-362P008-AU | 28.84 (1.135) | 23.34 (0.918) | 17.84 (0.702) | 7.62 (0.3) |
| 16 | FCN-362P016-AU | 39.0 (1.535) | 33.5 (1.318) | 28.0 (1.102) | 17.78 (0.7) |
| 24 | FCN-362P024-AU | 49.16 (1.935) | 43.66 (1.718) | 38.16 (1.502) | 27.94 (1.1) |
| 32 | FCN-362P032-AU | 59.32 (2.335) | 53.82 (2.118) | 48.32 (1.902) | 38.1 (1.5) |
| 40 | FCN-362P040-AU | 69.48 (2.735) | 63.98 (2.518) | 58.48 (2.302) | 48.26 (1.9) |
| 48 | FCN-362P048-AU | 79.64 (3.135) | 74.14 (2.918) | 68.64 (2.702) | 58.42 (2.3) |
| 56 | FCN-362P056-AU | 89.8 (3.535) | 84.3 (3.318) | 78.8 (3.102) | 68.58 (2.7) |
| 64 | FCN-362P064-AU | 99.96 (3.935) | 94.46 (3.718) | 88.96 (3.502) | 78.74 (3.1) |

FCN-360 Series

WIRE-WRAP TYPE (JACK)

■ DIMENSIONS

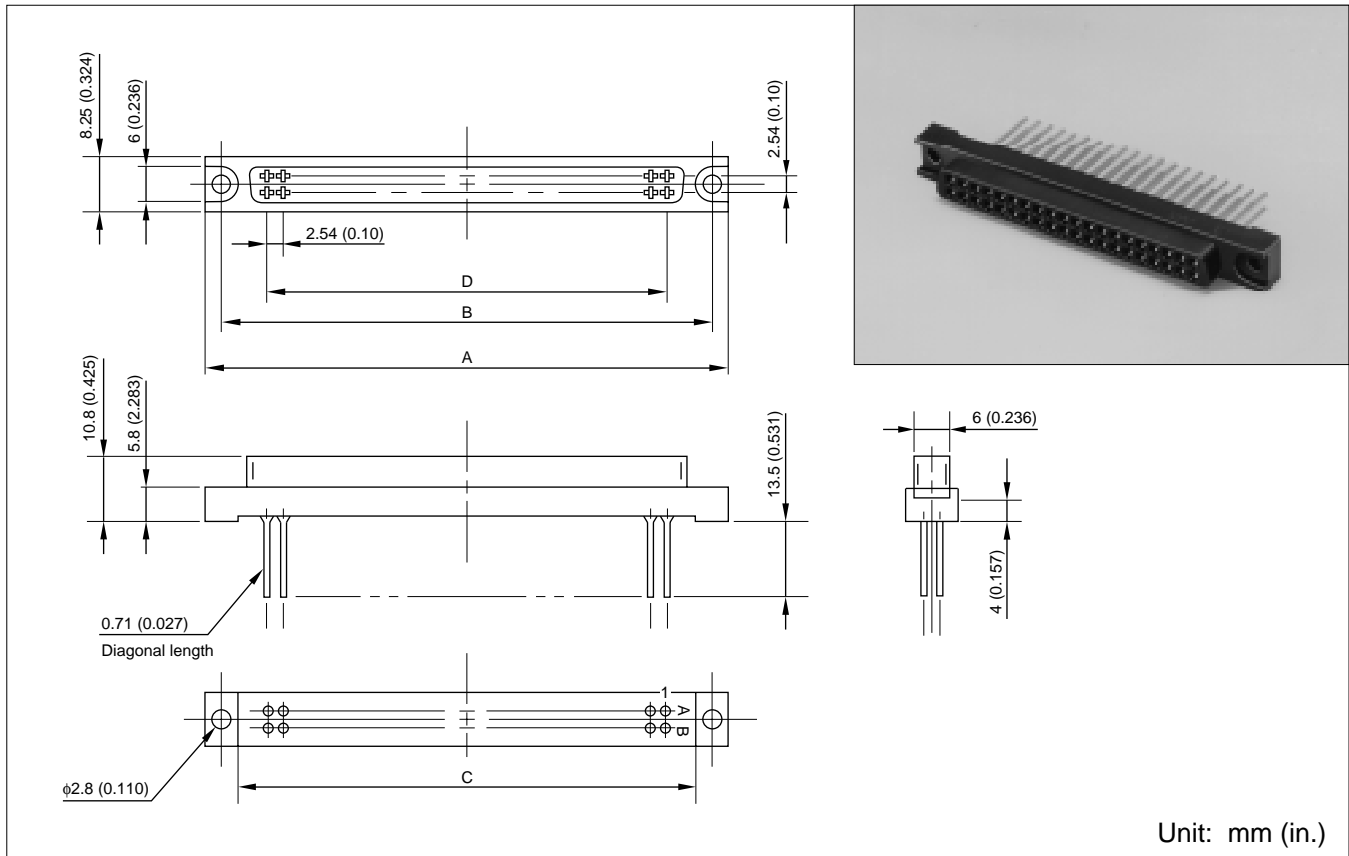

■ MOUNTING HOLE LAYOUT

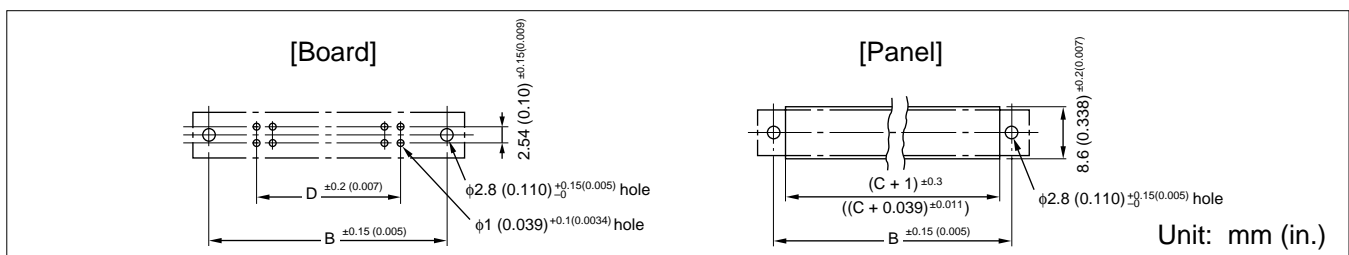

■ PART NUMBERS AND DIMENSIONS

| Number of contacts | Part number | Dimensions: mm (in.) | | | |
|--------------------|----------------|----------------------|---------------|---------------|-------------|
| | | A | B | C | D |
| 8 | FCN-362J008-AU | 28.84 (1.135) | 23.34 (0.918) | 17.84 (0.702) | 7.62 (0.3) |
| 16 | FCN-362J016-AU | 39.0 (1.535) | 33.5 (1.318) | 28.0 (1.102) | 17.78 (0.7) |
| 24 | FCN-362J024-AU | 49.16 (1.935) | 43.66 (1.718) | 38.16 (1.502) | 27.94 (1.1) |
| 32 | FCN-362J032-AU | 59.32 (2.335) | 53.82 (2.118) | 48.32 (1.902) | 38.1 (1.5) |
| 40 | FCN-362J040-AU | 69.48 (2.735) | 63.98 (2.518) | 58.48 (2.302) | 48.26 (1.9) |
| 48 | FCN-362J048-AU | 79.64 (3.135) | 74.14 (2.918) | 68.64 (2.702) | 58.42 (2.3) |
| 56 | FCN-362J056-AU | 89.8 (3.535) | 84.3 (3.318) | 78.8 (3.102) | 68.58 (2.7) |
| 64 | FCN-362J064-AU | 99.96 (3.935) | 94.46 (3.718) | 88.96 (3.502) | 78.74 (3.1) |

FCN-360 Series

CRIMP TYPE (JACK HOUSING)

■ DIMENSIONS

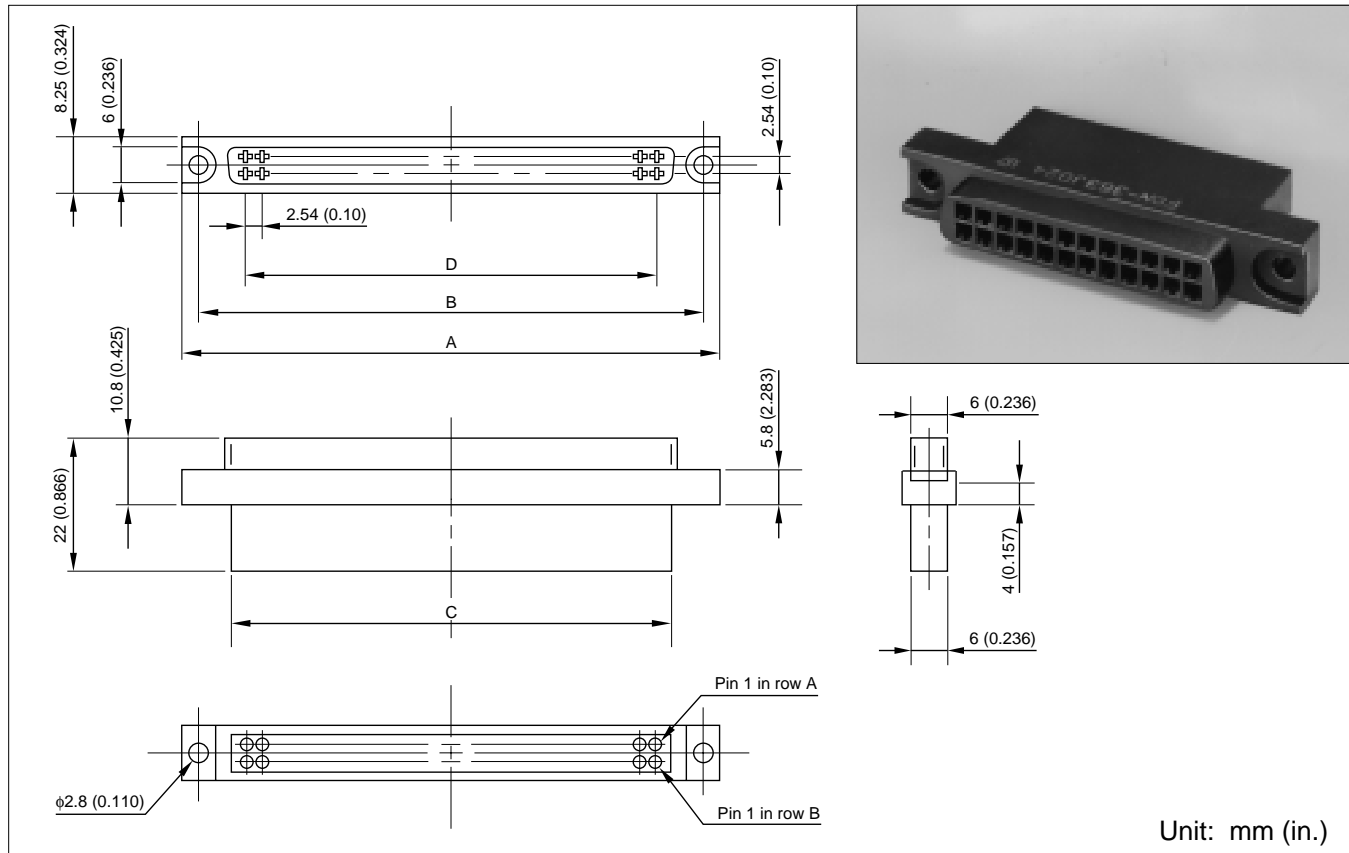

■ MOUNTING HOLE LAYOUT

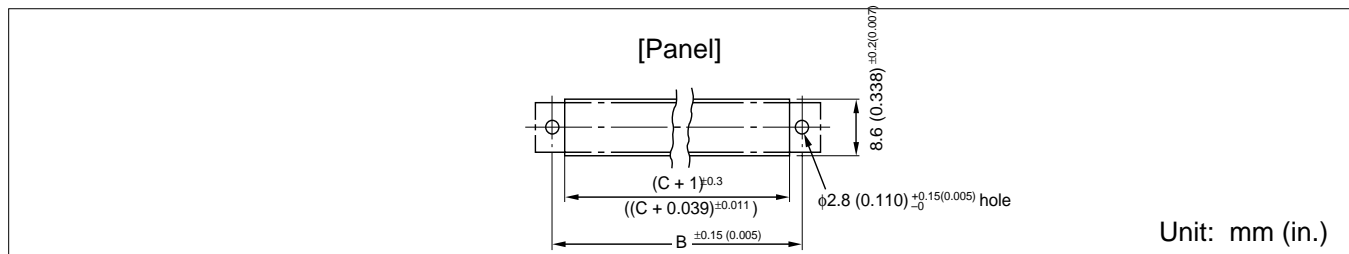

■ PART NUMBERS AND DIMENSIONS

| Number of contacts | Part number | Dimensions: mm (in.) | | | |
|--------------------|-------------|----------------------|---------------|---------------|-------------|
| | | A | B | C | D |
| 8 | FCN-363J008 | 28.84 (1.135) | 23.34 (0.918) | 17.84 (0.702) | 7.62 (0.3) |
| 16 | FCN-363J016 | 39.0 (1.535) | 33.5 (1.318) | 28.0 (1.102) | 17.78 (0.7) |
| 24 | FCN-363J024 | 49.16 (1.935) | 43.66 (1.718) | 38.16 (1.502) | 27.94 (1.1) |
| 32 | FCN-363J032 | 59.32 (2.335) | 53.82 (2.118) | 48.32 (1.902) | 38.1 (1.5) |
| 40 | FCN-363J040 | 69.48 (2.735) | 63.98 (2.518) | 58.48 (2.302) | 48.26 (1.9) |
| 48 | FCN-363J048 | 79.64 (3.135) | 74.14 (2.918) | 68.64 (2.702) | 58.42 (2.3) |
| 56 | FCN-363J056 | 89.8 (3.535) | 84.3 (3.318) | 78.8 (3.102) | 68.58 (2.7) |
| 64 | FCN-363J064 | 99.96 (3.935) | 94.46 (3.718) | 88.96 (3.502) | 78.74 (3.1) |

FCN-360 Series

CRIMP TYPE (CONTACT)

■ DIMENSIONS

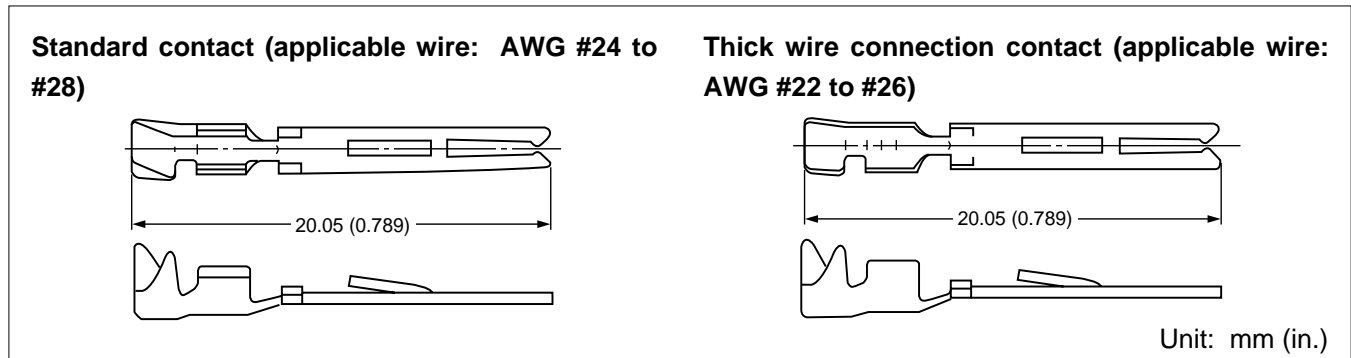

■ PART NUMBERS

| Type | Plating | Standard | Thick wire connection contact |
|--------------|--------------|---------------|-------------------------------|
| Loose piece | Gold plating | FCN-363J-AU | FCN-363J-AU/S |
| Strip reeled | Gold plating | FCN-363J-AU/R | FCN-363J-AU/T |

■ PART NUMBERS OF CRIMPING TOOLS

| Part number | Contact type | Applicable wire | Wire cross-section area (mm ²) | Crimp height | Insulator diameter | Stripped length |
|--|---------------------------------|-----------------|--|---|---|---|
| FCN-363T-T005/H (Hand crimping tool) | FCN-363J-AU (Loose piece) | AWG #24 | 0.20 to 0.24 | 1.25 mm (0.049 in.) to 1.30 mm (0.051 in.) | φ1.2 mm (0.047 in.) max | 3.0 mm (0.118 in.) to 4.0 mm (0.157 in.) |
| FCN-M110 (Automatic crimping machine) | FCN-363J-AU/R (Strip reeled) | AWG #26 | 0.13 to 0.16 | 1.20 mm (0.047 in.) to 1.25 mm (0.049 in.) | φ1.2 mm (0.047 in.) max | 3.0 mm (0.118 in.) to 4.0 mm (0.157 in.) |
| FCN-A105 (Applicator) | | AWG #28 | 0.088 to 0.096 | 1.15 mm (0.045 in.) to 1.20 mm (0.047 in.) | φ1.2 mm (0.047 in.) max | 3.0 mm (0.118 in.) to 4.0 mm (0.157 in.) |
| FCN-363T-T011/H (Hand crimping tool) | FCN-363J-AU/S (Loose piece) | AWG #22 | 0.30 to 0.40 | 0.85 mm (0.033 in.) to 0.95 mm (0.037 in.) | φ0.9 mm (0.035 in.) 1.8 mm (0.071 in.) | 3.0 mm (0.118 in.) to 4.0 mm (0.157 in.) |
| FCN-M110 (Automatic crimping machine) | FCN-363J-AU/T (Strip reeled) | AWG #24 | 0.20 to 0.24 | 0.75 mm (0.029 in.) to 0.85 mm (0.033 in.) | φ0.9 mm (0.035 in.) 1.8 mm (0.071 in.) | 3.0 mm (0.118 in.) to 4.0 mm (0.157 in.) |
| FCN-A111 (Applicator) | | AWG #26 | 0.13 to 0.16 | 0.73 mm (0.028 in.) to 0.81 mm (0.031 in.) | φ0.9 mm (0.035 in.) 1.8 mm (0.071 in.) | 3.0 mm (0.118 in.) to 4.0 mm (0.157 in.) |

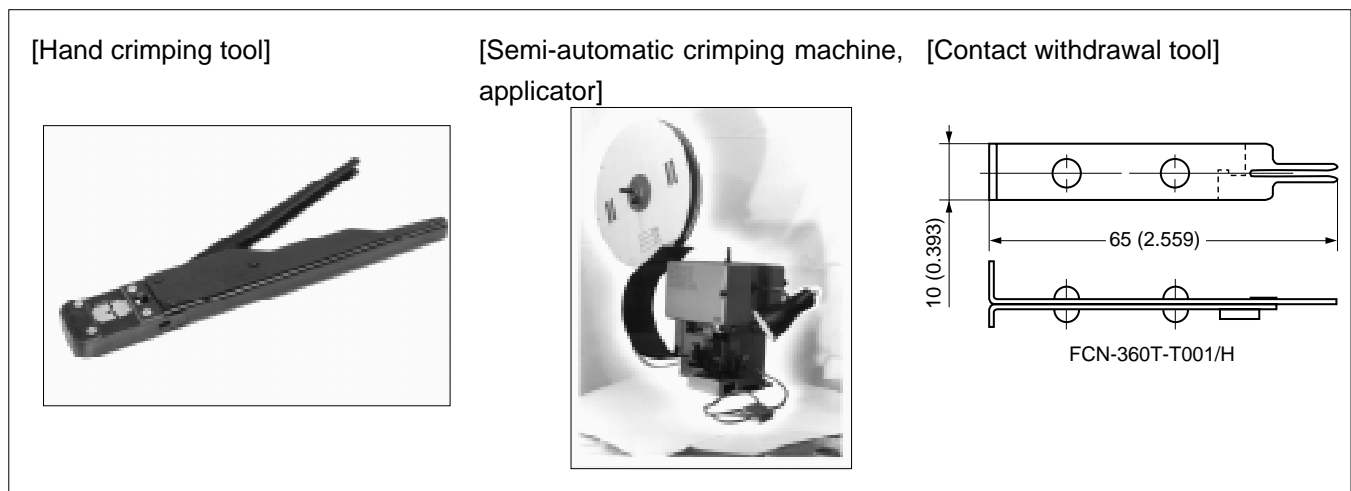

STRAIGHT TYPE (PLUG)

■ DIMENSIONS

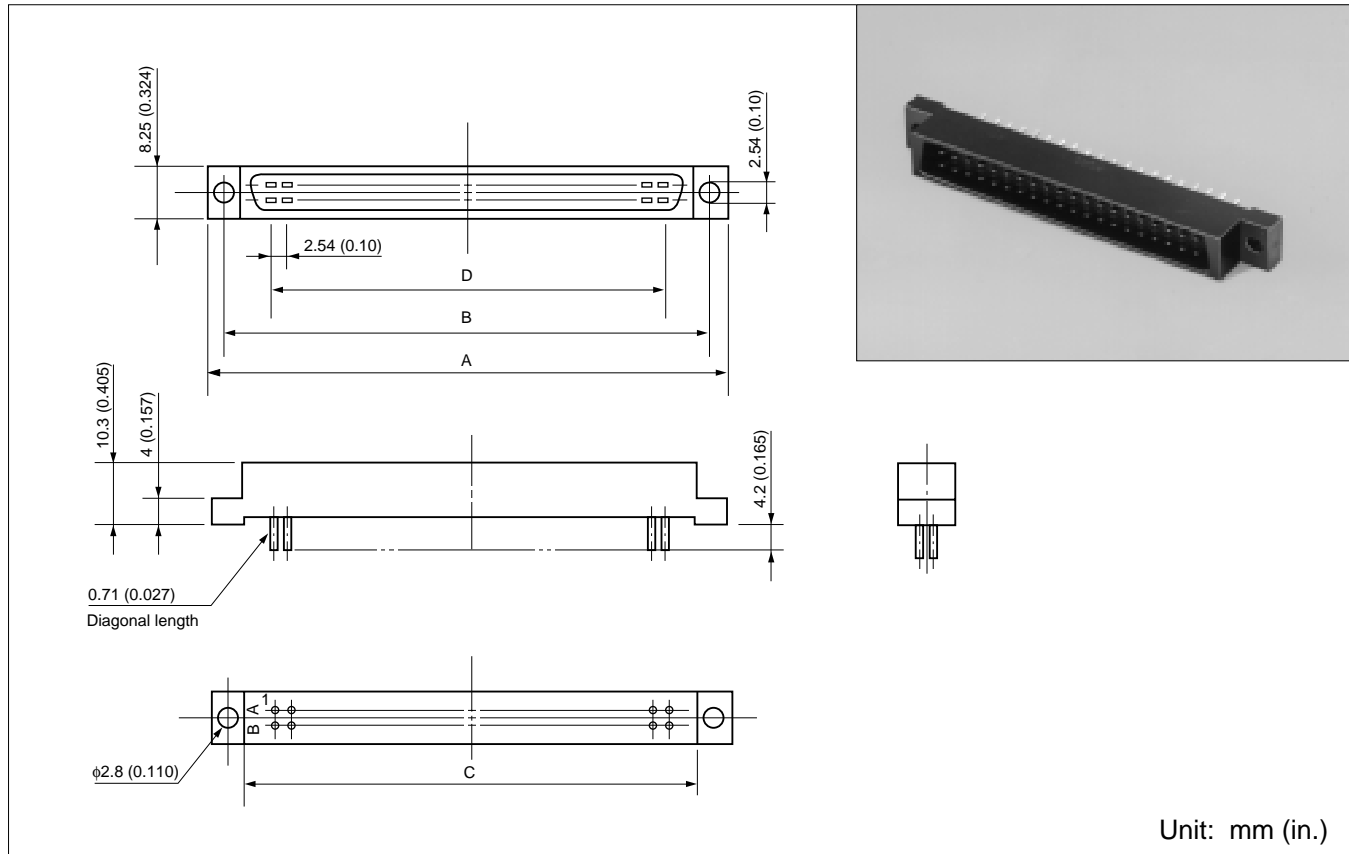

■ BOARD MOUNTING HOLE LAYOUT

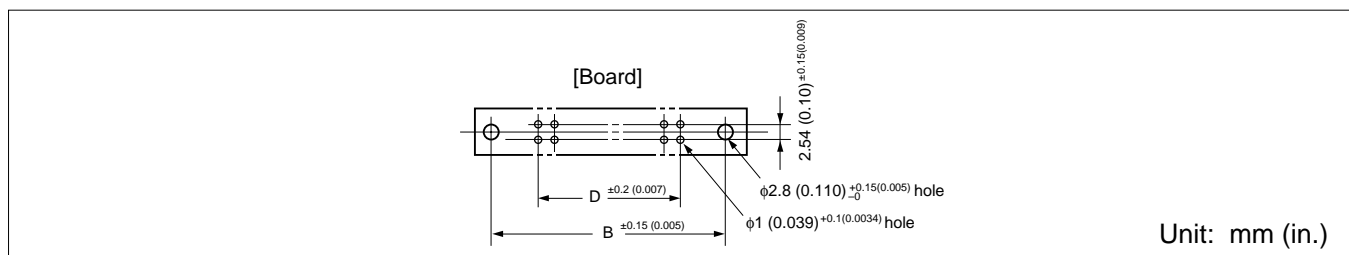

■ PART NUMBERS AND DIMENSIONS

| Number of contacts | Part number | Dimensions: mm (in.) | | | |
|--------------------|----------------|----------------------|---------------|---------------|-------------|
| | | A | B | C | D |
| 8 | FCN-364P008-AU | 28.84 (1.135) | 23.34 (0.918) | 17.84 (0.702) | 7.62 (0.3) |
| 16 | FCN-364P016-AU | 39.0 (1.535) | 33.5 (1.318) | 28.0 (1.102) | 17.78 (0.7) |
| 24 | FCN-364P024-AU | 49.16 (1.935) | 43.66 (1.718) | 38.16 (1.502) | 27.94 (1.1) |
| 32 | FCN-364P032-AU | 59.32 (2.335) | 53.82 (2.118) | 48.32 (1.902) | 38.1 (1.5) |
| 40 | FCN-364P040-AU | 69.48 (2.735) | 63.98 (2.518) | 58.48 (2.302) | 48.26 (1.9) |
| 48 | FCN-364P048-AU | 79.64 (3.135) | 74.14 (2.918) | 68.64 (2.702) | 58.42 (2.3) |
| 56 | FCN-364P056-AU | 89.8 (3.535) | 84.3 (3.318) | 78.8 (3.102) | 68.58 (2.7) |
| 64 | FCN-364P064-AU | 99.96 (3.935) | 94.46 (3.718) | 88.96 (3.502) | 78.74 (3.1) |

STRAIGHT TYPE (JACK)

■ DIMENSIONS

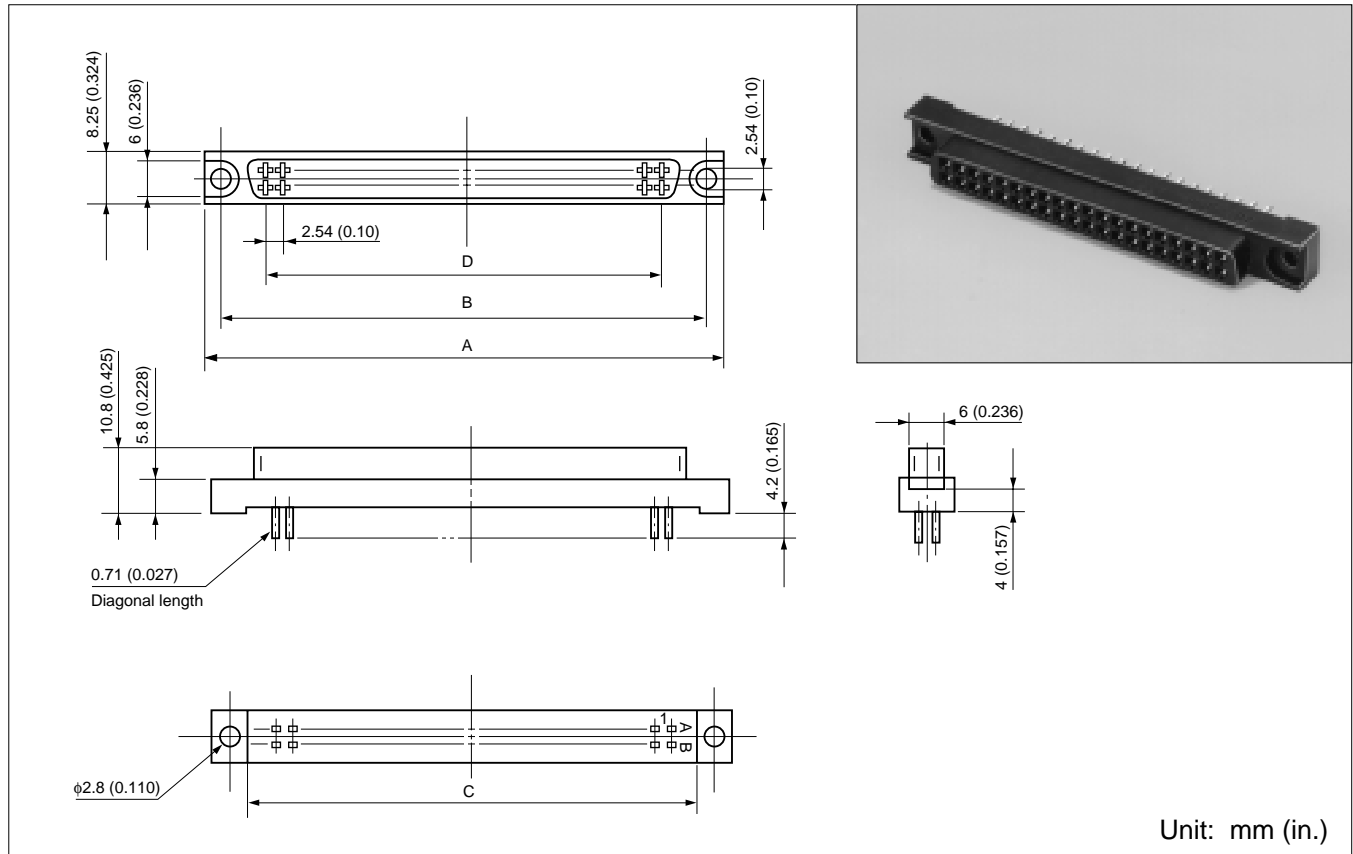

■ BOARD MOUNTING HOLE LAYOUT

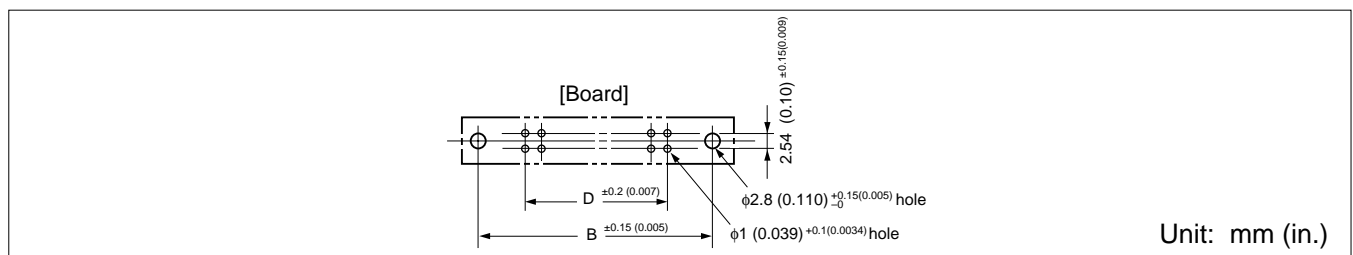

■ PART NUMBERS AND DIMENSIONS

| Number of contacts | Part number | Dimensions: mm (in.) | | | |
|--------------------|----------------|----------------------|---------------|---------------|-------------|
| | | A | B | C | D |
| 8 | FCN-364J008-AU | 28.84 (1.135) | 23.34 (0.918) | 17.84 (0.702) | 7.62 (0.3) |
| 16 | FCN-364J016-AU | 39.0 (1.535) | 33.5 (1.318) | 28.0 (1.102) | 17.78 (0.7) |
| 24 | FCN-364J024-AU | 49.16 (1.935) | 43.66 (1.718) | 38.16 (1.502) | 27.94 (1.1) |
| 32 | FCN-364J032-AU | 59.32 (2.335) | 53.82 (2.118) | 48.32 (1.902) | 38.1 (1.5) |
| 40 | FCN-364J040-AU | 69.48 (2.735) | 63.98 (2.518) | 58.48 (2.302) | 48.26 (1.9) |
| 48 | FCN-364J048-AU | 79.64 (3.135) | 74.14 (2.918) | 68.64 (2.702) | 58.42 (2.3) |
| 56 | FCN-364J056-AU | 89.8 (3.535) | 84.3 (3.318) | 78.8 (3.102) | 68.58 (2.7) |
| 64 | FCN-364J064-AU | 99.96 (3.935) | 94.46 (3.718) | 88.96 (3.502) | 78.74 (3.1) |

RIGHT-ANGLE TYPE (PLUG)

■ DIMENSIONS

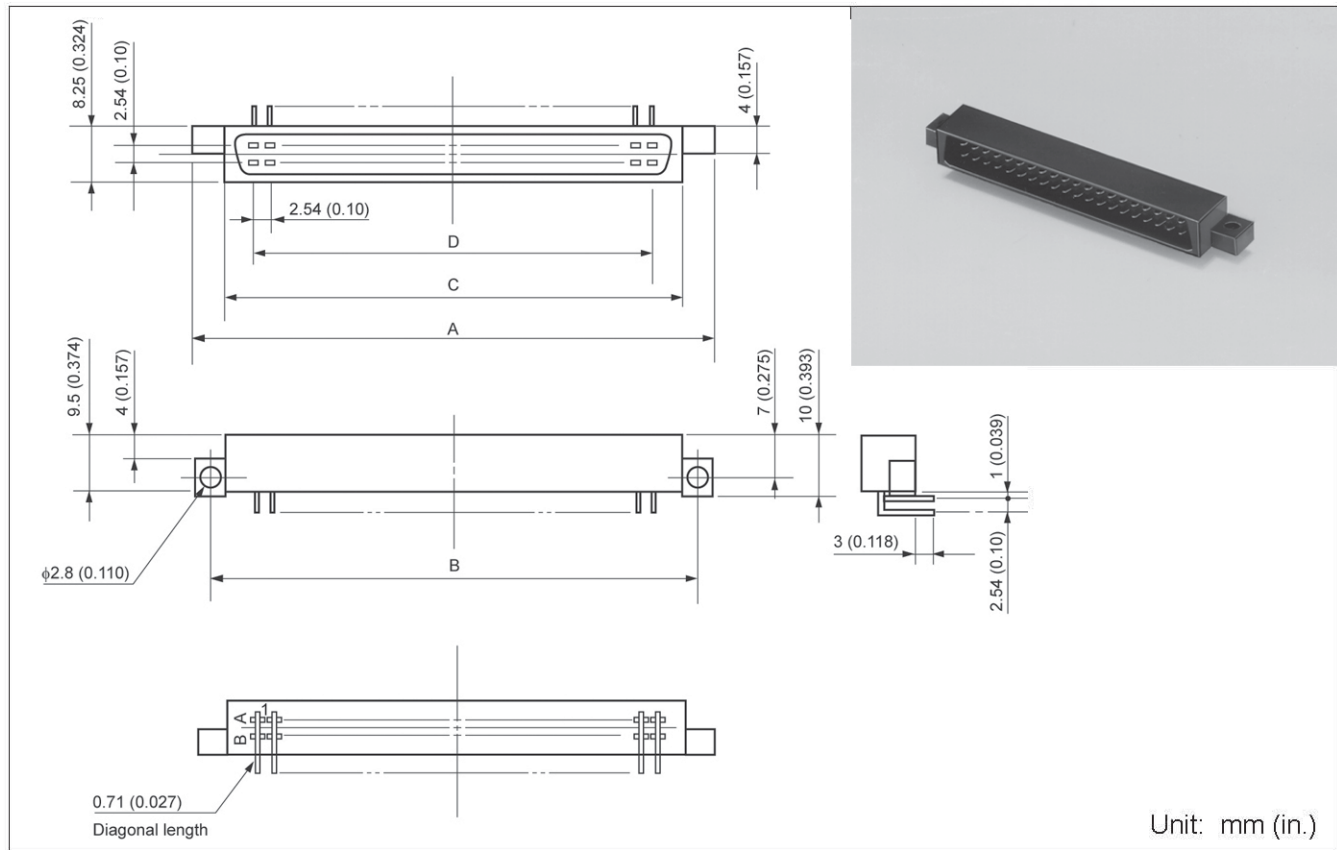

■ MOUNTING HOLE LAYOUT



■ NOTE

- Note on mounting a right-angle plug on a board

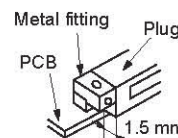

Mount the connector so that it projects from the board by at least 1.5 mm (0.059 in.).

■ PART NUMBERS AND DIMENSIONS

| Number of contacts | Part number | Dimensions: mm (in.) | | | |
|--------------------|----------------|----------------------|---------------|---------------|-------------|
| | | A | B | C | D |
| 8 | FCN-365P008-AU | 28.84 (1.135) | 23.34 (0.918) | 17.84 (0.702) | 7.62 (0.3) |
| 16 | FCN-365P016-AU | 39.0 (1.535) | 33.5 (1.318) | 28.0 (1.102) | 17.78 (0.7) |
| 24 | FCN-365P024-AU | 49.16 (1.935) | 43.66 (1.718) | 38.16 (1.502) | 27.94 (1.1) |
| 32 | FCN-365P032-AU | 59.32 (2.335) | 53.82 (2.118) | 48.32 (1.902) | 38.1 (1.5) |
| 40 | FCN-365P040-AU | 69.48 (2.735) | 63.98 (2.518) | 58.48 (2.302) | 48.26 (1.9) |
| 48 | FCN-365P048-AU | 79.64 (3.135) | 74.14 (2.918) | 68.64 (2.702) | 58.42 (2.3) |
| 56 | FCN-365P056-AU | 89.8 (3.535) | 84.3 (3.318) | 78.8 (3.102) | 68.58 (2.7) |
| 64 | FCN-365P064-AU | 99.96 (3.935) | 94.46 (3.718) | 88.96 (3.502) | 78.74 (3.1) |

RIGHT-ANGLE TYPE (FOR DUAL STACKED MOUNTING [40 CONTACTS ONLY])

■ DIMENSIONS

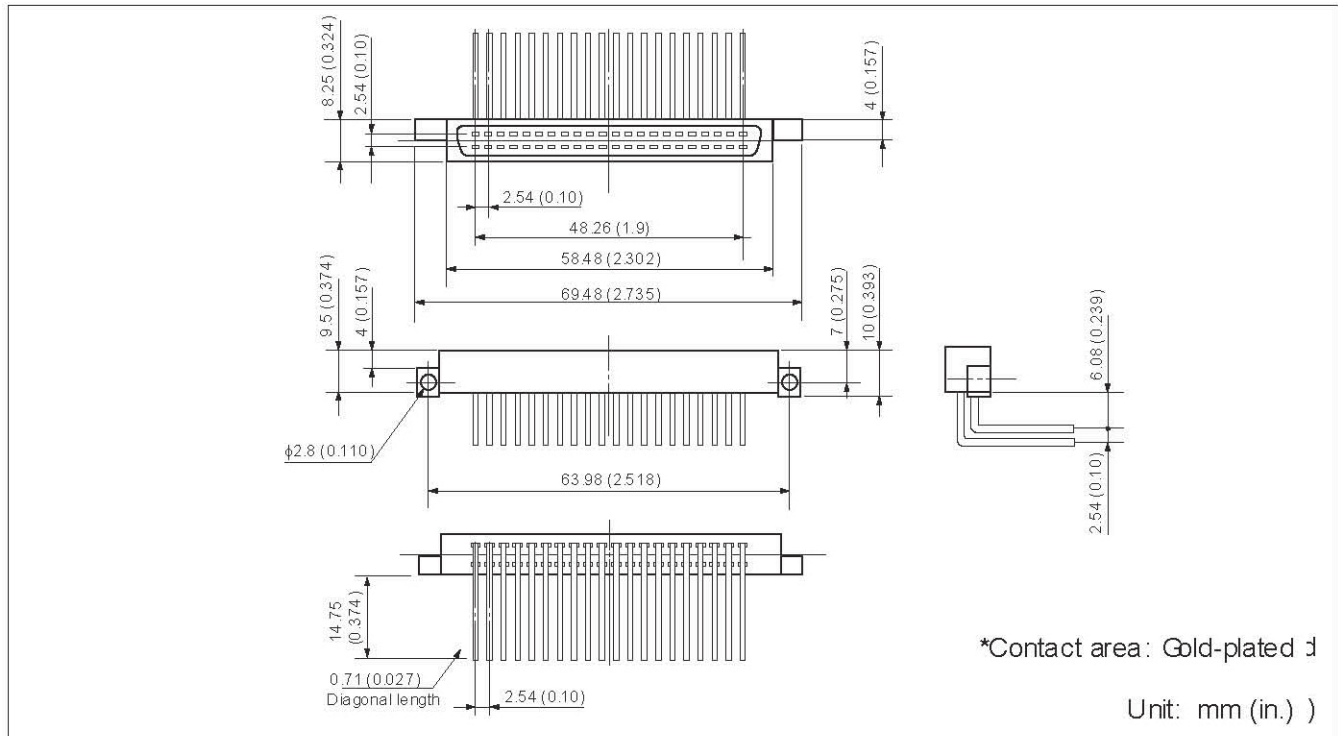

■ MOUNTING HOLE LAYOUT

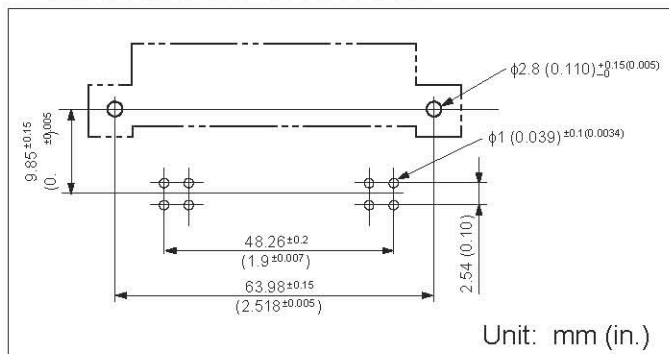

■ METAL FITTINGS FOR DUAL ROW MOUNTING

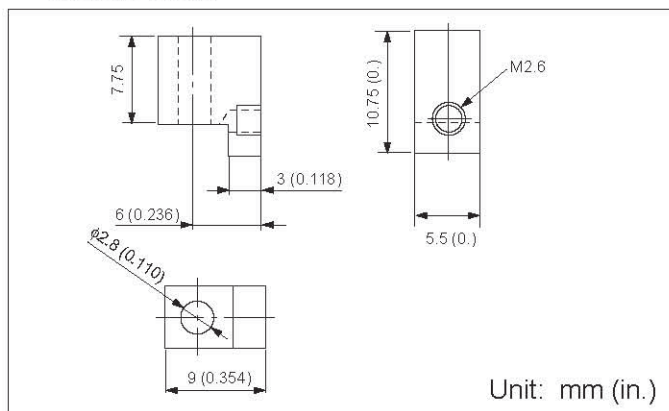

■ PART NUMBER

Right-angle type: N630-3651-T919
Metal fittings: N630-3608-X038

■ MOUNTING

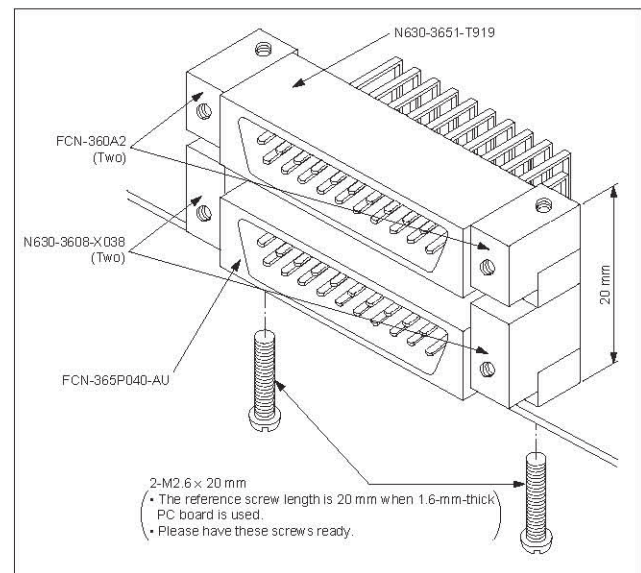

RIGHT-ANGLE TYPE (JACK) ■ DIMENSIONS

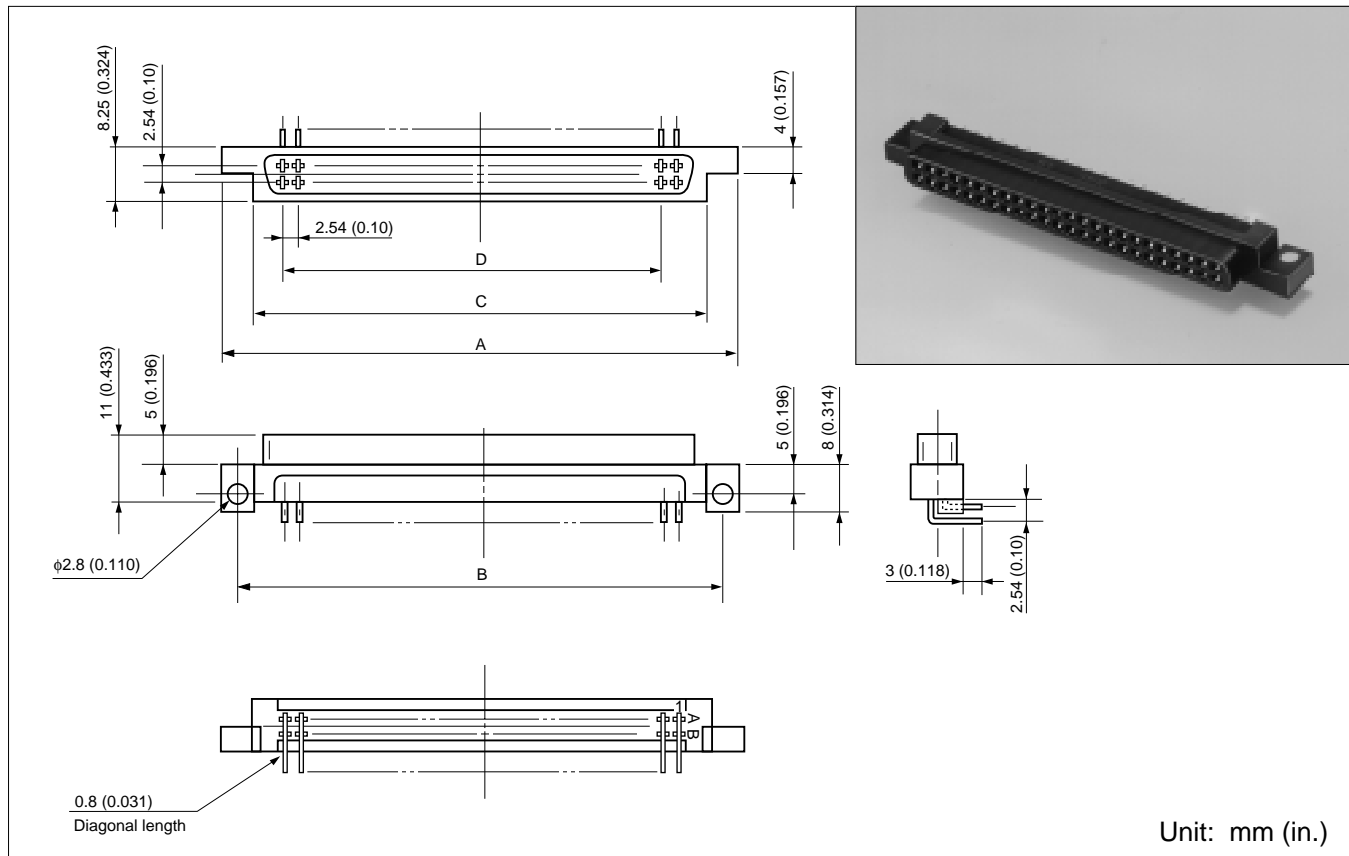

■ MOUNTING HOLE LAYOUT

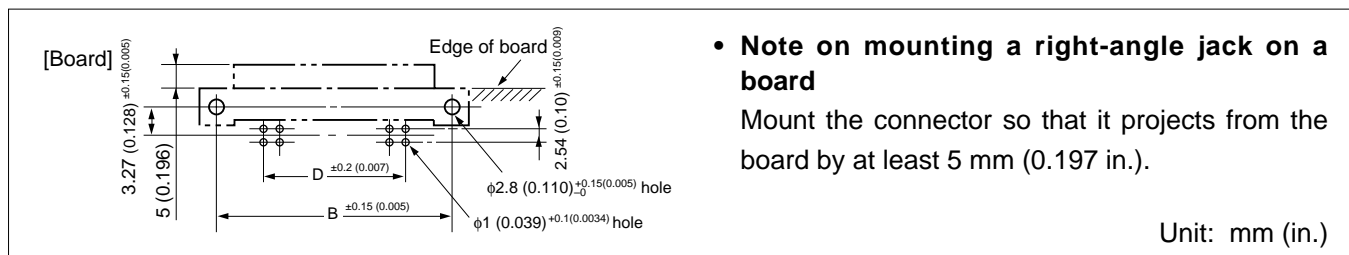

■ PART NUMBERS AND DIMENSIONS

| Number of contacts | Part number | Dimensions: mm (in.) | | | |
|--------------------|----------------|----------------------|---------------|---------------|-------------|
| | | A | B | C | D |
| 8 | FCN-365J008-AU | 28.84 (1.135) | 23.34 (0.918) | 17.84 (0.702) | 7.62 (0.3) |
| 16 | FCN-365J016-AU | 39.0 (1.535) | 33.5 (1.318) | 28.0 (1.102) | 17.78 (0.7) |
| 24 | FCN-365J024-AU | 49.16 (1.935) | 43.66 (1.718) | 38.16 (1.502) | 27.94 (1.1) |
| 32 | FCN-365J032-AU | 59.32 (2.335) | 53.82 (2.118) | 48.32 (1.902) | 38.1 (1.5) |
| 40 | FCN-365J040-AU | 69.48 (2.735) | 63.98 (2.518) | 58.48 (2.302) | 48.26 (1.9) |
| 48 | FCN-365J048-AU | 79.64 (3.135) | 74.14 (2.918) | 68.64 (2.702) | 58.42 (2.3) |
| 56 | FCN-365J056-AU | 89.8 (3.535) | 84.3 (3.318) | 78.8 (3.102) | 68.58 (2.7) |
| 64 | FCN-365J064-AU | 99.96 (3.935) | 94.46 (3.718) | 88.96 (3.502) | 78.74 (3.1) |

IDC TYPE (JACK)

■ DIMENSIONS

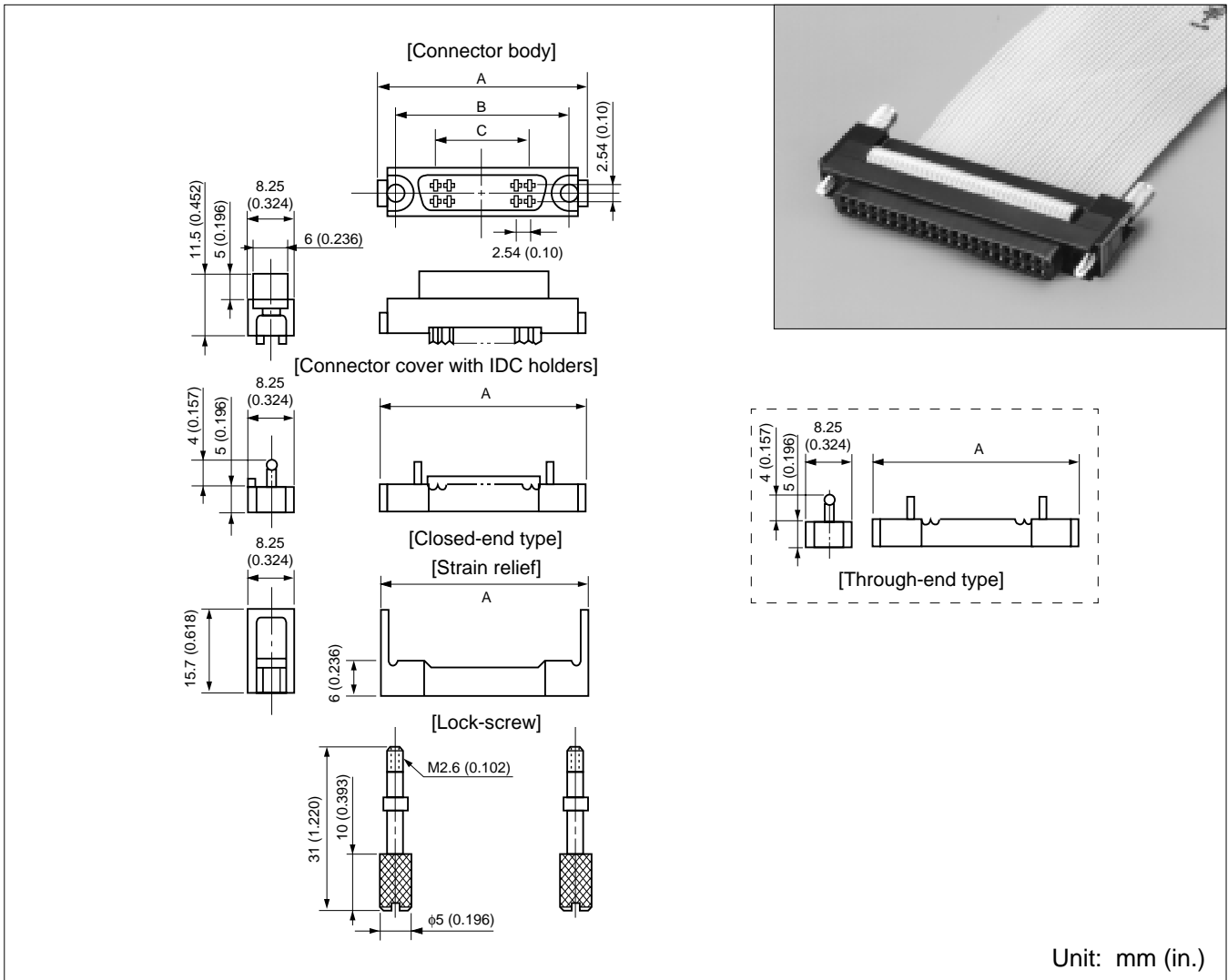

■ PART NUMBERS AND DIMENSIONS

| Number of contacts | Part number | | Dimensions: mm (in.) | | |
|--------------------|-------------------|------------------|----------------------|---------------|-------------|
| | Through-end cover | Close-end cover | A | B | D |
| 8 | FCN-367J008-AU/H | FCN-367J008-AU/F | 28.84 (1.135) | 23.34 (0.918) | 7.62 (0.3) |
| 16 | FCN-367J016-AU/H | FCN-367J016-AU/F | 39.0 (1.535) | 33.5 (1.318) | 17.78 (0.7) |
| 24 | FCN-367J024-AU/H | FCN-367J024-AU/F | 49.16 (1.935) | 43.66 (1.718) | 27.94 (1.1) |
| 32 | FCN-367J032-AU/H | FCN-367J032-AU/F | 59.32 (2.335) | 53.82 (2.118) | 38.1 (1.5) |
| 40 | FCN-367J040-AU/H | FCN-367J040-AU/F | 69.48 (2.735) | 63.98 (2.518) | 48.26 (1.9) |
| 48 | FCN-367J048-AU/H | FCN-367J048-AU/F | 79.64 (3.135) | 74.14 (2.918) | 58.42 (2.3) |
| 56 | FCN-367J056-AU/H | FCN-367J056-AU/F | 89.8 (3.535) | 84.3 (3.318) | 68.58 (2.7) |
| 64 | FCN-367J064-AU/H | FCN-367J064-AU/F | 99.96 (3.935) | 94.46 (3.718) | 78.74 (3.1) |

IDC TOOLS

Special IDC tools are used to assemble FCN-360 series connectors and flat cables.

■ FEATURES

- The mechanisms are simple, so even novices can use them easily.
- Those who already have Fujitsu-manufactured IDC tools for other series connectors need only purchase the locator plate.

The hand press and cable cutter are designed to be used in common with all connectors.

- The assembly of cables and connectors with various numbers of contacts can be done by selective setting of the connector guides to the specified positions.
- The cable cutter has an extremely sharp cutting edge.

Notes:

- A detailed operation manual and instruction manual for IDC tools are available upon request.
- Should any question arise in using the IDC tools, consult our branch offices or agents in your area.

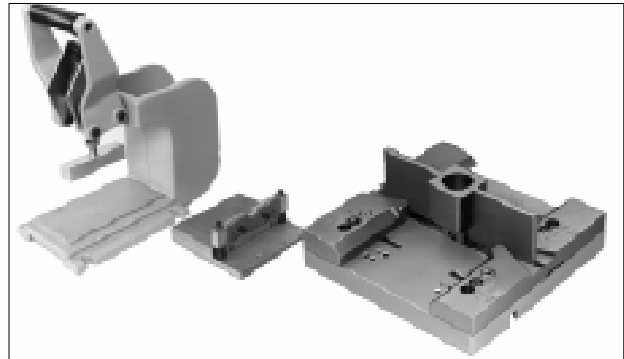

Hand press Cable cutter Locator plate (That for the 790 series is shown in the photograph.)

■ ORDERING CODES FOR IDC TOOLS

| Tool name | Part number |
|---|-----------------|
| Cable cutter (common) | FCN-707T-T001/H |
| Hand press (common) | FCN-707T-T101/H |
| Locator plate (for 360 series connectors) | FCN-367T-T012/H |

The hand press and cable cutter can be used for other IDC connectors.

COVER

■ COMBINATIONS BETWEEN COVERS AND CONNECTORS

| Cover \ Connector | Plug | Jack | | | Number of contacts | | | | | | | |
|-------------------|-----------|-----------|---------------|----------|--------------------|----|----|----|----|----|----|----|
| | Soldering | Soldering | Wire-wrapping | Crimping | 8 | 16 | 24 | 32 | 40 | 48 | 56 | 64 |
| FCN-360C□□□-B | ○ | ○ | ○ | ○ | ○ | ○ | ○ | ○ | ○ | ○ | ○ | ○ |
| FCN-360C□□□-C | ○ | ○ | ○ | ○ | ○ | ○ | ○ | ○ | ○ | ○ | ○ | ○ |
| FCN-360C□□□-D | ○ | ○ | ○ | ○ | | | | | ○ | ○ | ○ | ○ |
| FCN-360C□□□-E | ○ | ○ | ○ | ○ | ○ | ○ | ○ | ○ | ○ | ○ | ○ | ○ |
| FCN-360C064-F | ○ | ○ | ○ | ○ | | | | | | | | ○ |
| FCN-360C040-G1 | ○ | ○ | ○ | ○ | | | | | ○ | | | |
| FCN-360C040-H/E | ○ | ○ | | | | | | | ○ | | | |
| FCN-360C040-J1 | ○ | ○ | | | | | | | ○ | | | |

These covers cannot be used for IDC connectors.

FCN-360 Series

COVER (TYPE B)

■ DIMENSIONS

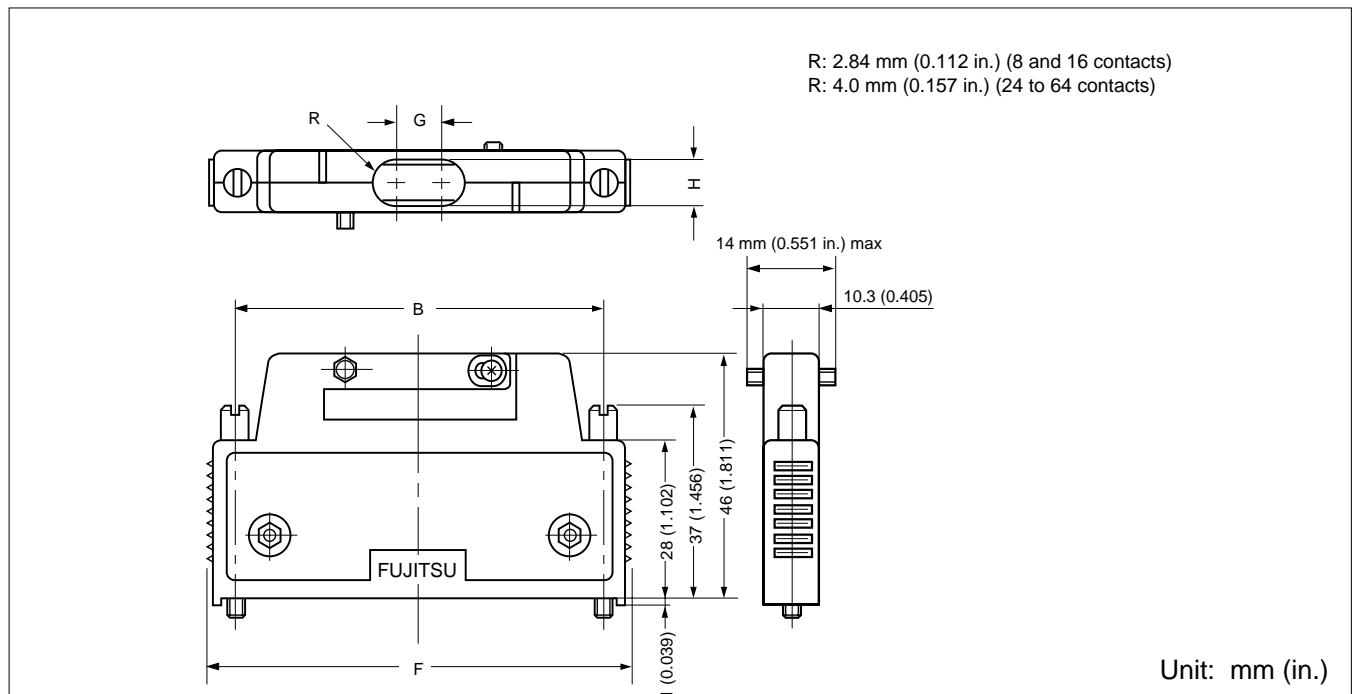

■ EXPLODED VIEW

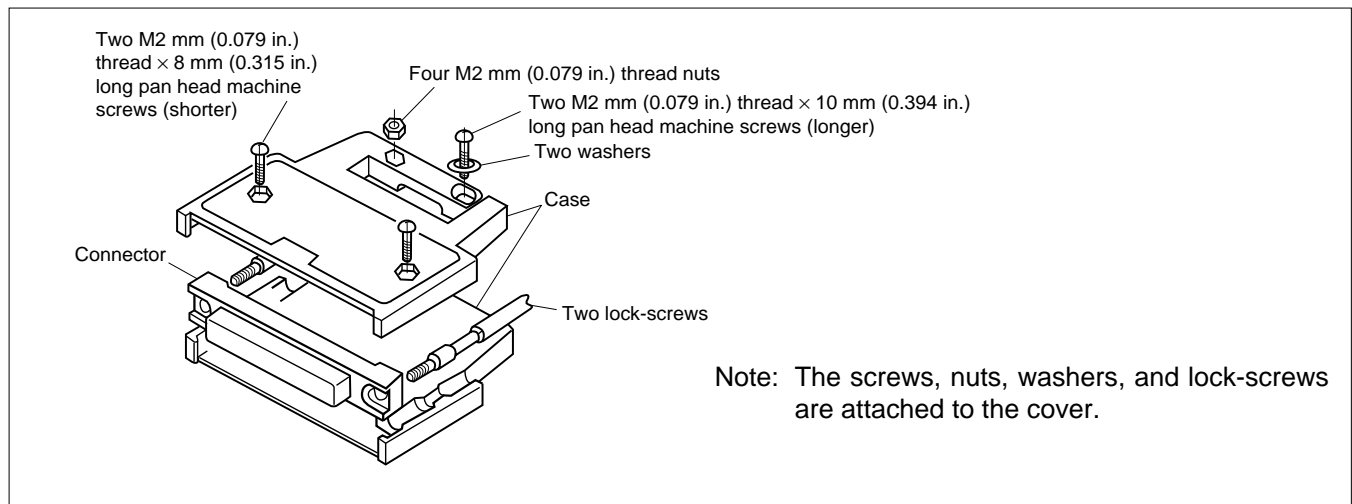

■ PART NUMBERS AND DIMENSIONS

| Number of contacts | Part number | Dimensions: mm (in.) | | | |
|--------------------|---------------|----------------------|----------------|--------------|---------------|
| | | B | F | G | H |
| 8 | FCN-360C008-B | 23.34 (0.918) | 32.08 (1.262) | — | φ 5.7 (0.224) |
| 16 | FCN-360C016-B | 33.50 (1.318) | 42.24 (1.662) | — | φ 5.7 (0.224) |
| 24 | FCN-360C024-B | 43.66 (1.718) | 52.40 (2.062) | — | φ 8.0 (0.314) |
| 32 | FCN-360C032-B | 53.82 (2.118) | 62.56 (2.462) | 2.0 (0.078) | 8.0 (0.314) |
| 40 | FCN-360C040-B | 63.98 (2.518) | 72.72 (2.862) | 6.0 (0.236) | 8.0 (0.314) |
| 48 | FCN-360C048-B | 74.14 (2.918) | 82.88 (3.262) | 10.0 (0.393) | 8.0 (0.314) |
| 56 | FCN-360C056-B | 84.30 (3.318) | 93.04 (3.662) | 14.0 (0.551) | 8.0 (0.314) |
| 64 | FCN-360C064-B | 94.46 (3.718) | 103.20 (4.062) | 18.0 (0.708) | 8.0 (0.314) |

FCN-360 Series

COVER FOR CABLE TO CABLE CONNECTION (TYPE C)

■ DIMENSIONS

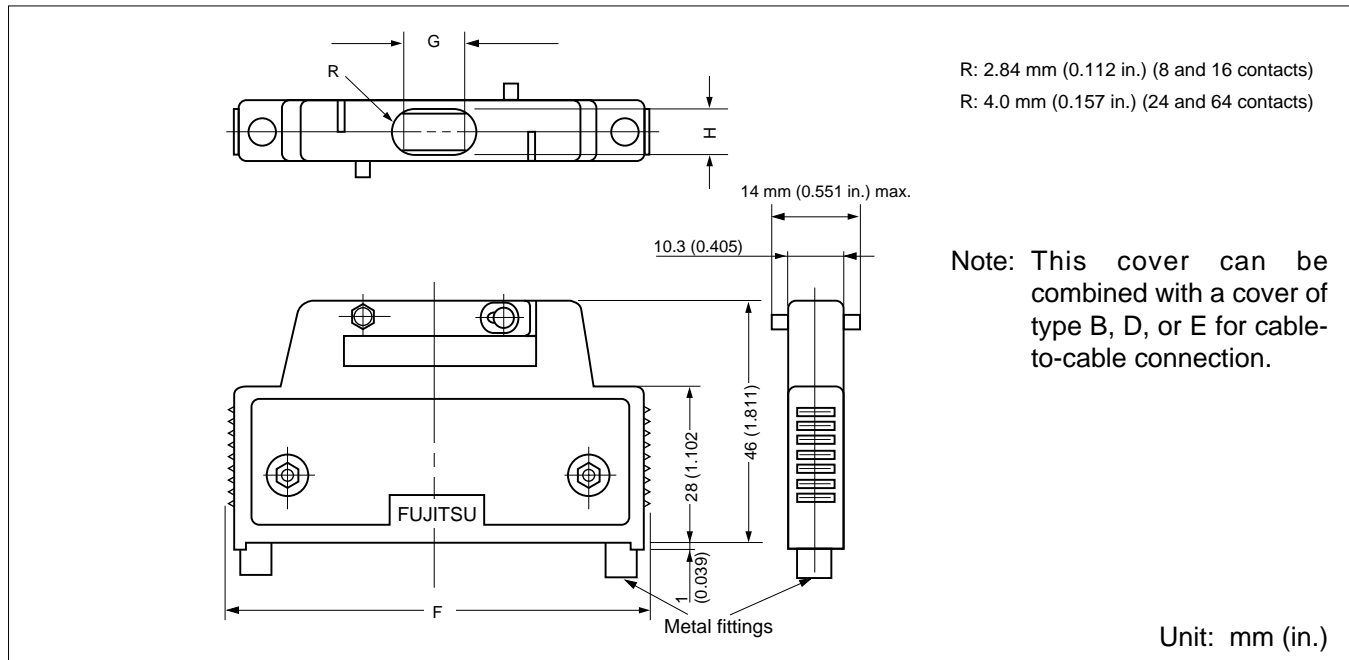

■ EXPLODED VIEW

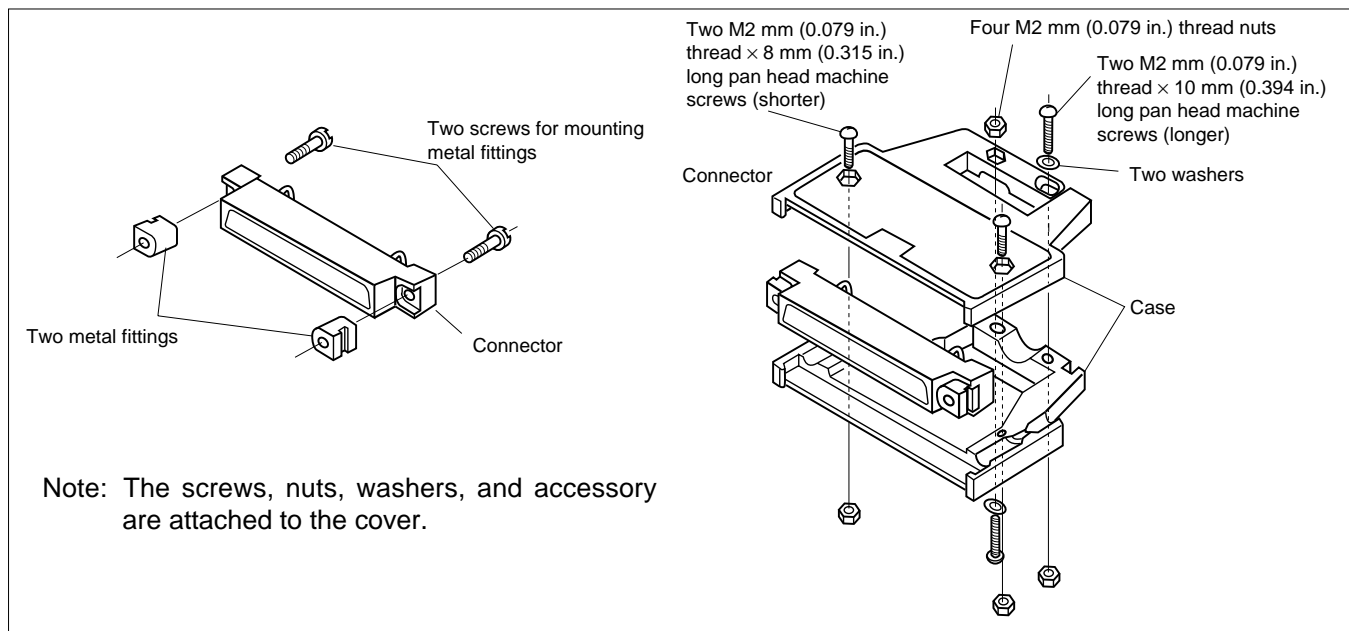

■ PART NUMBERS AND DIMENSIONS

| Number of contacts | Part number | Dimensions: mm (in.) | | |
|--------------------|---------------|----------------------|--------------|---------------|
| | | F | G | H |
| 8 | FCN-360C008-C | 32.08 (1.262) | — | φ 5.7 (0.224) |
| 16 | FCN-360C016-C | 42.24 (1.662) | — | φ 5.7 (0.224) |
| 24 | FCN-360C024-C | 52.40 (2.062) | — | φ 8.0 (0.314) |
| 32 | FCN-360C032-C | 62.56 (2.462) | 2.0 (0.078) | 8.0 (0.314) |
| 40 | FCN-360C040-C | 72.72 (2.862) | 6.0 (0.236) | 8.0 (0.314) |
| 48 | FCN-360C048-C | 82.88 (3.262) | 10.0 (0.393) | 8.0 (0.314) |
| 56 | FCN-360C056-C | 93.04 (3.662) | 14.0 (0.551) | 8.0 (0.314) |
| 64 | FCN-360C064-C | 103.20 (4.062) | 18.0 (0.708) | 8.0 (0.314) |

COVER (WIDE OPENING TYPE) (TYPE D)

■ DIMENSIONS

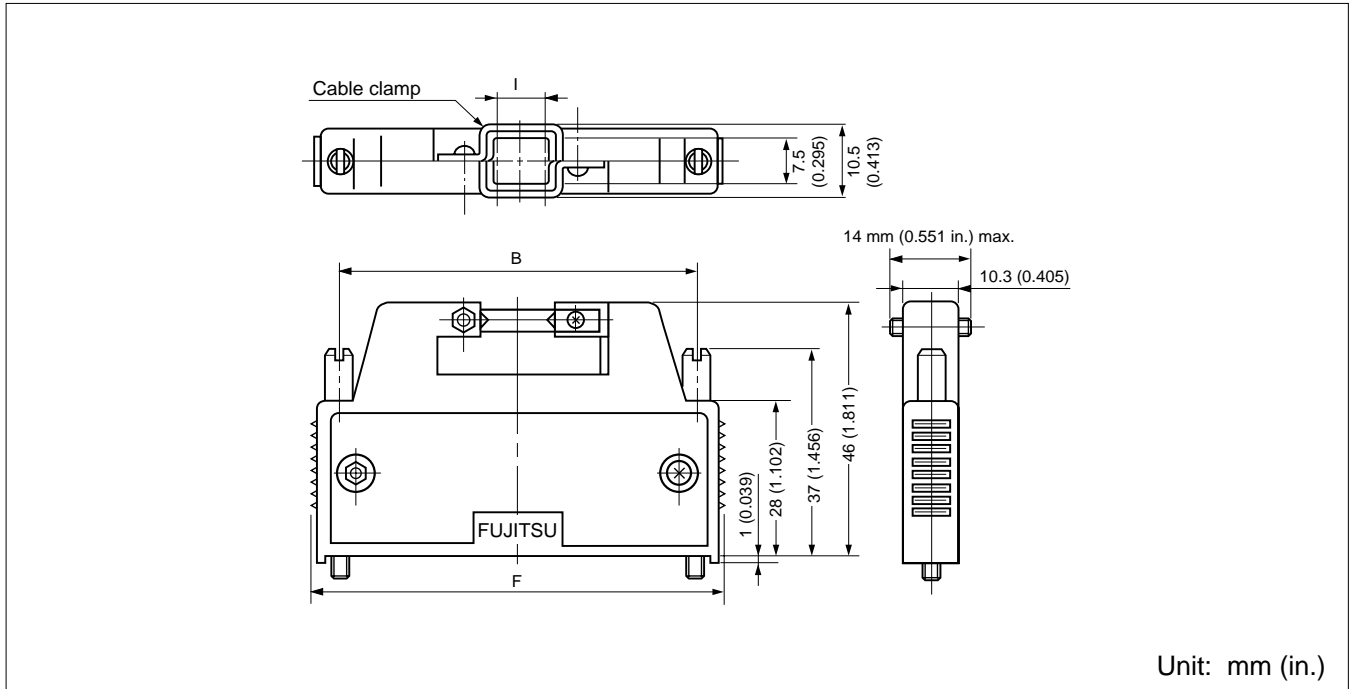

■ EXPLODED VIEW

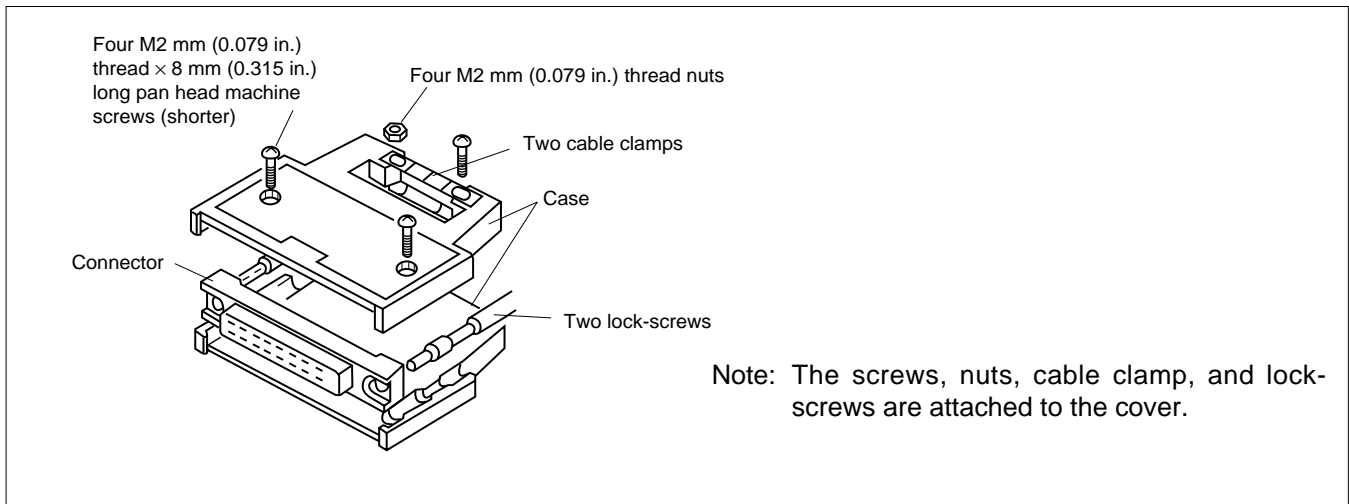

■ PART NUMBERS AND DIMENSIONS

| Number of contacts | Part number | Dimensions: mm (in.) | | |
|--------------------|---------------|----------------------|----------------|--------------|
| | | B | F | I |
| 40 | FCN-360C040-D | 63.98 (2.518) | 72.72 (2.862) | 8.0 (0.314) |
| 48 | FCN-360C048-D | 74.14 (2.918) | 82.88 (3.262) | 12.0 (0.472) |
| 56 | FCN-360C056-D | 84.30 (3.318) | 93.04 (3.662) | 16.0 (0.629) |
| 64 | FCN-360C064-D | 94.46 (3.718) | 103.20 (4.062) | 20.0 (0.789) |

COVER (LONG-SCREW TYPE) (TYPE E)

■ DIMENSIONS

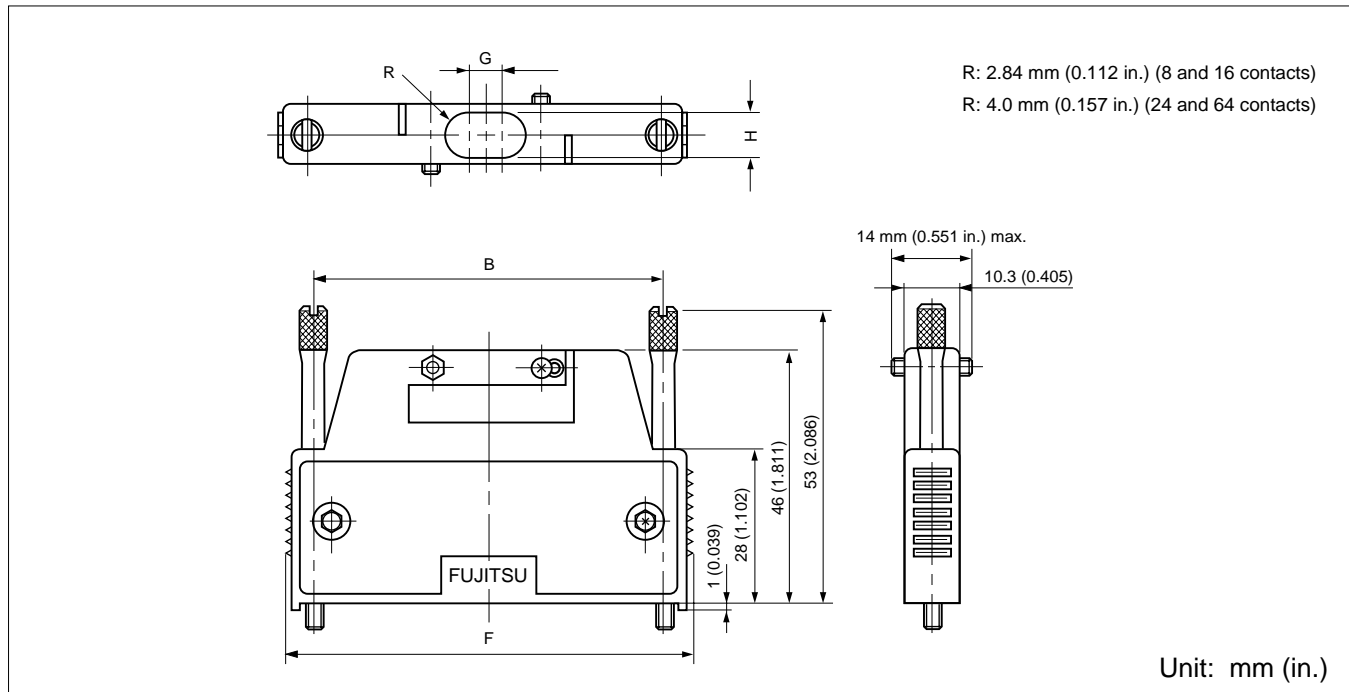

■ EXPLODED VIEW

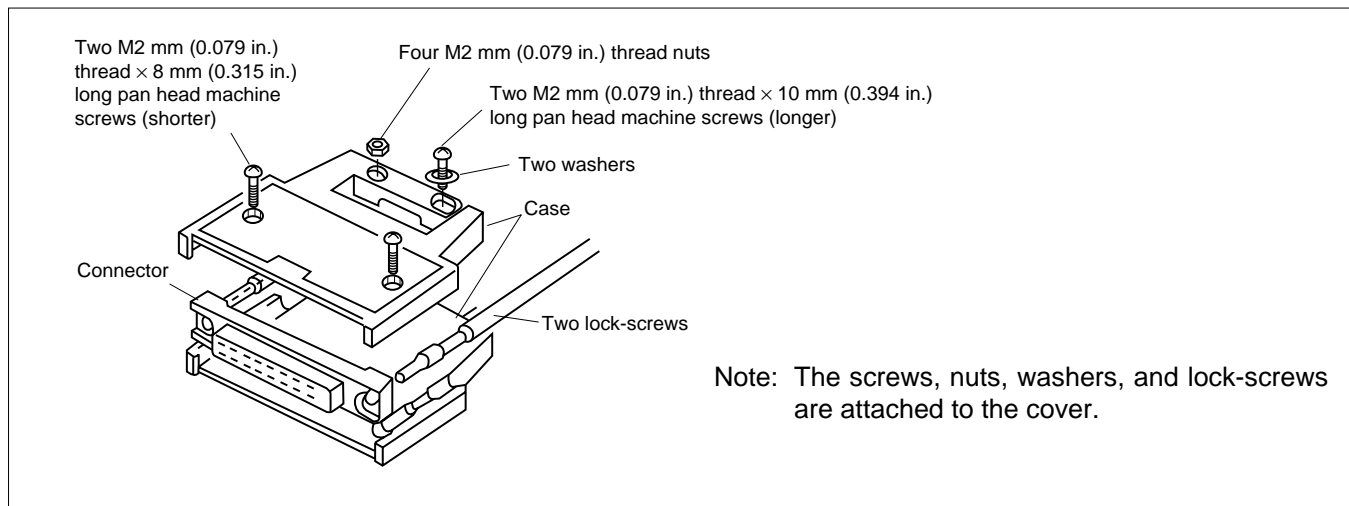

■ PART NUMBERS AND DIMENSIONS

| Number of contacts | Part number | Dimensions: mm (in.) | | | |
|--------------------|---------------|----------------------|----------------|--------------|---------------|
| | | B | F | G | H |
| 8 | FCN-360C008-E | 23.34 (0.918) | 32.08 (1.262) | — | φ 5.7 (0.224) |
| 16 | FCN-360C016-E | 33.50 (1.318) | 42.24 (1.662) | — | φ 5.7 (0.224) |
| 24 | FCN-360C024-E | 43.66 (1.718) | 52.40 (2.062) | — | φ 8.0 (0.314) |
| 32 | FCN-360C032-E | 53.82 (2.118) | 62.56 (2.462) | 2.0 (0.078) | 8.0 (0.314) |
| 40 | FCN-360C040-E | 63.98 (2.518) | 72.72 (2.862) | 6.0 (0.236) | 8.0 (0.314) |
| 48 | FCN-360C048-E | 74.14 (2.918) | 82.88 (3.262) | 10.0 (0.393) | 8.0 (0.314) |
| 56 | FCN-360C056-E | 84.30 (3.318) | 93.04 (3.662) | 14.0 (0.551) | 8.0 (0.314) |
| 64 | FCN-360C064-E | 94.46 (3.718) | 103.20 (4.062) | 18.0 (0.708) | 8.0 (0.314) |

COVER (STRAIGHT CABLE-OUT COVER) (TYPE F)

■ DIMENSIONS

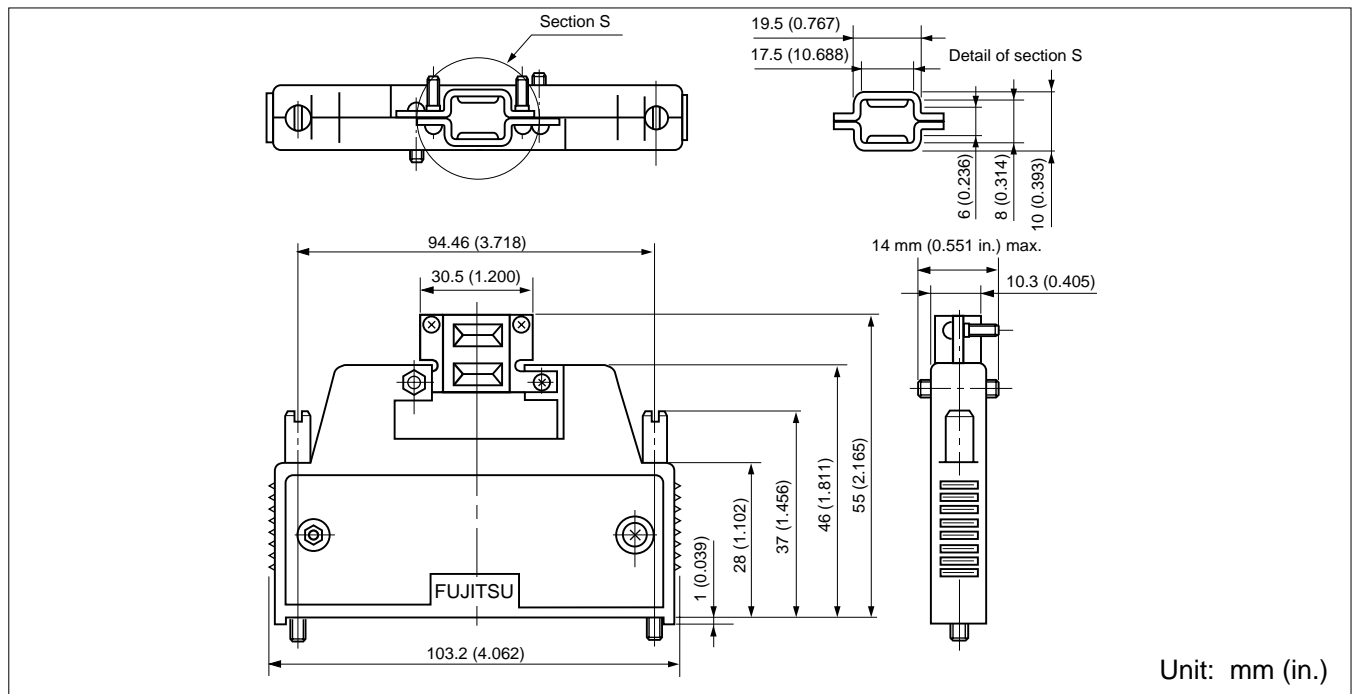

■ EXPLODED VIEW

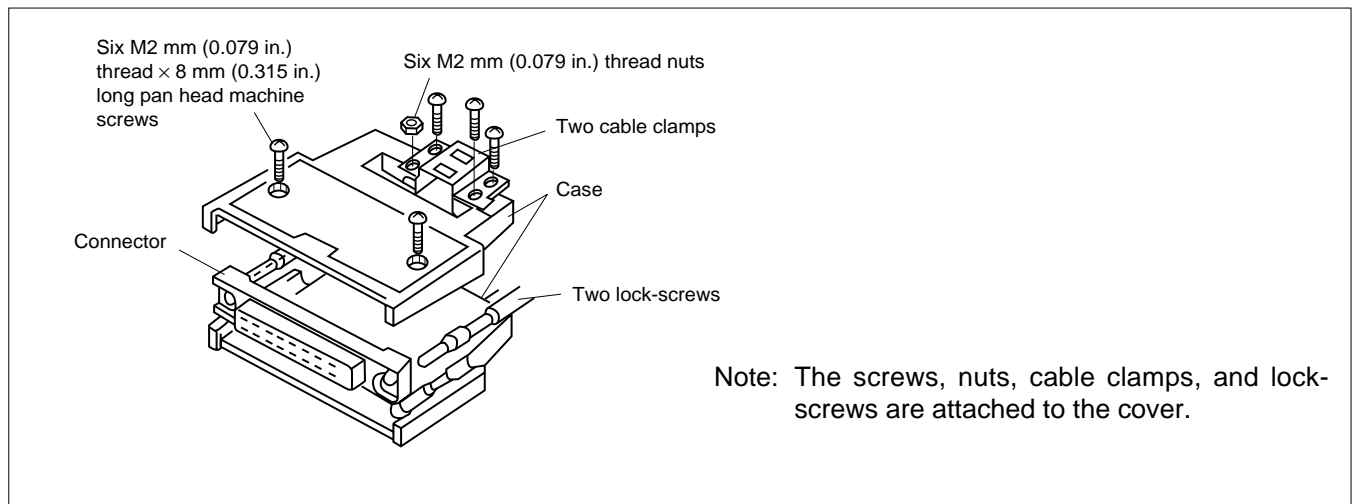

■ PART NUMBER

FCN-360C064-F

COVER (RIGHT ANGLE CABLE-OUT COVER) (TYPE G1)

■ DIMENSIONS

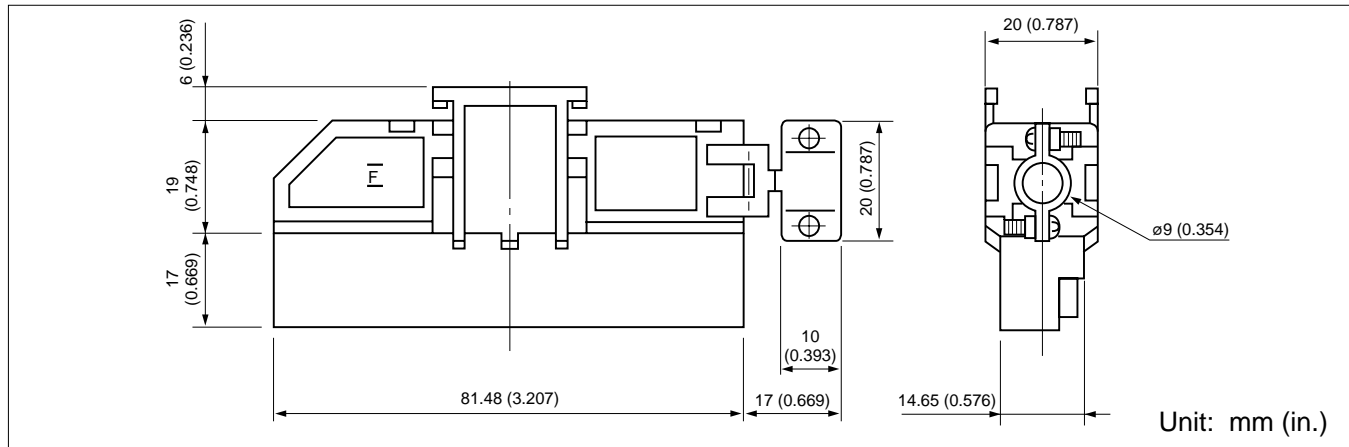

■ EXPLODED VIEW

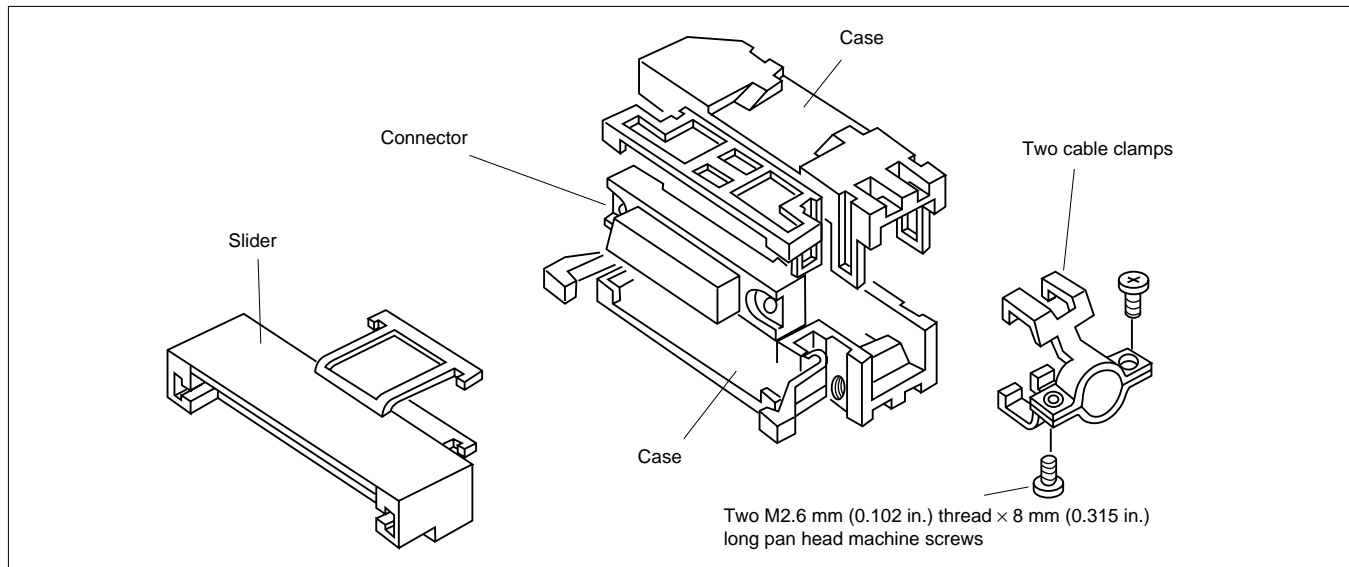

■ LOCKED STATE

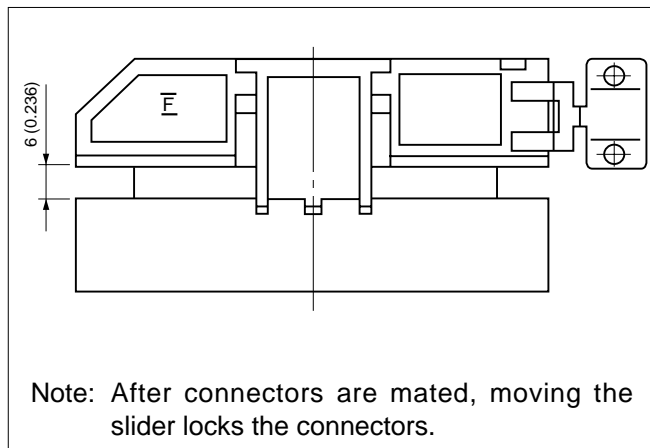

■ METAL FITTINGS

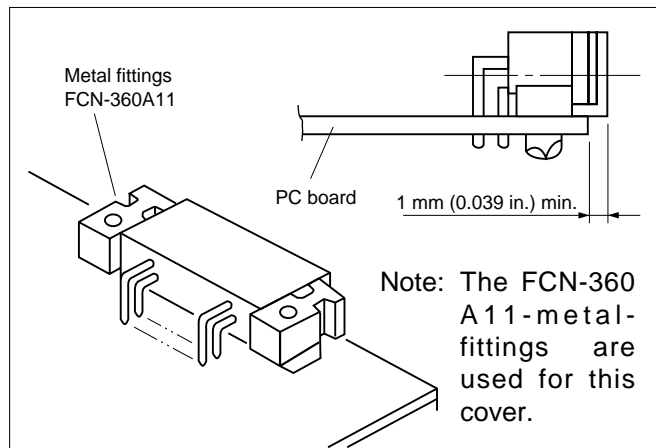

■ PART NUMBER

FCN-360C040-G1

COVER (RIGHT ANGLE CABLEOUT COVER) (TYPE H/E)

■ DIMENSIONS

Material: Zinc die cast

Plating: Nickel plating

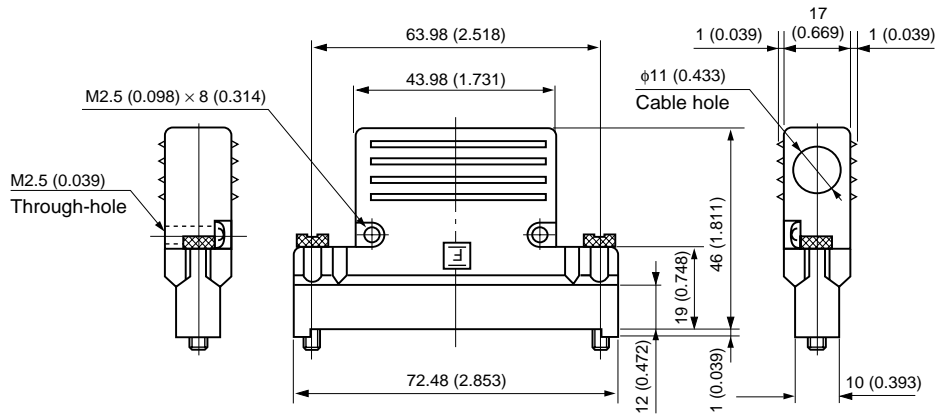

Unit: mm (in.)

■ EXPLODED VIEW

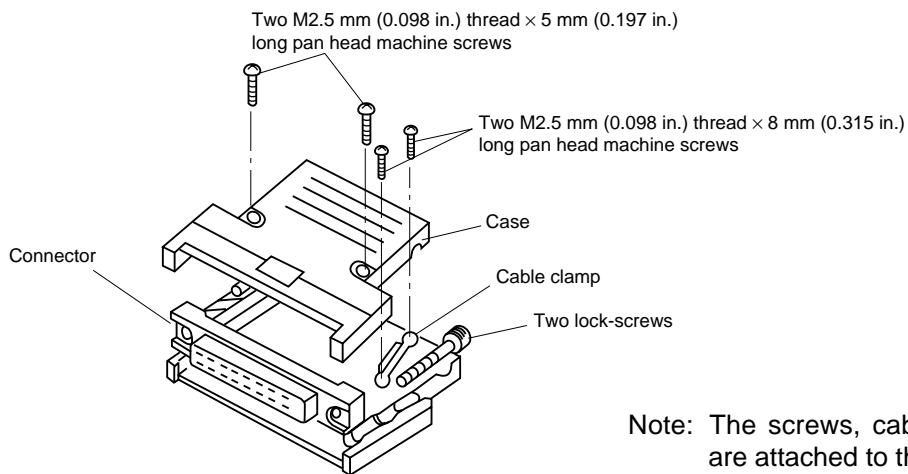

Note: The screws, cable clamp, and lock-screws are attached to the cover.

■ PART NUMBER

FCN-360C040-H/E

FCN-360 Series

COVER (OBTUSE ANGLE CABLE-OUT COVER (40 CONTACTS ONLY)) (TYPE J1)

■ DIMENSIONS

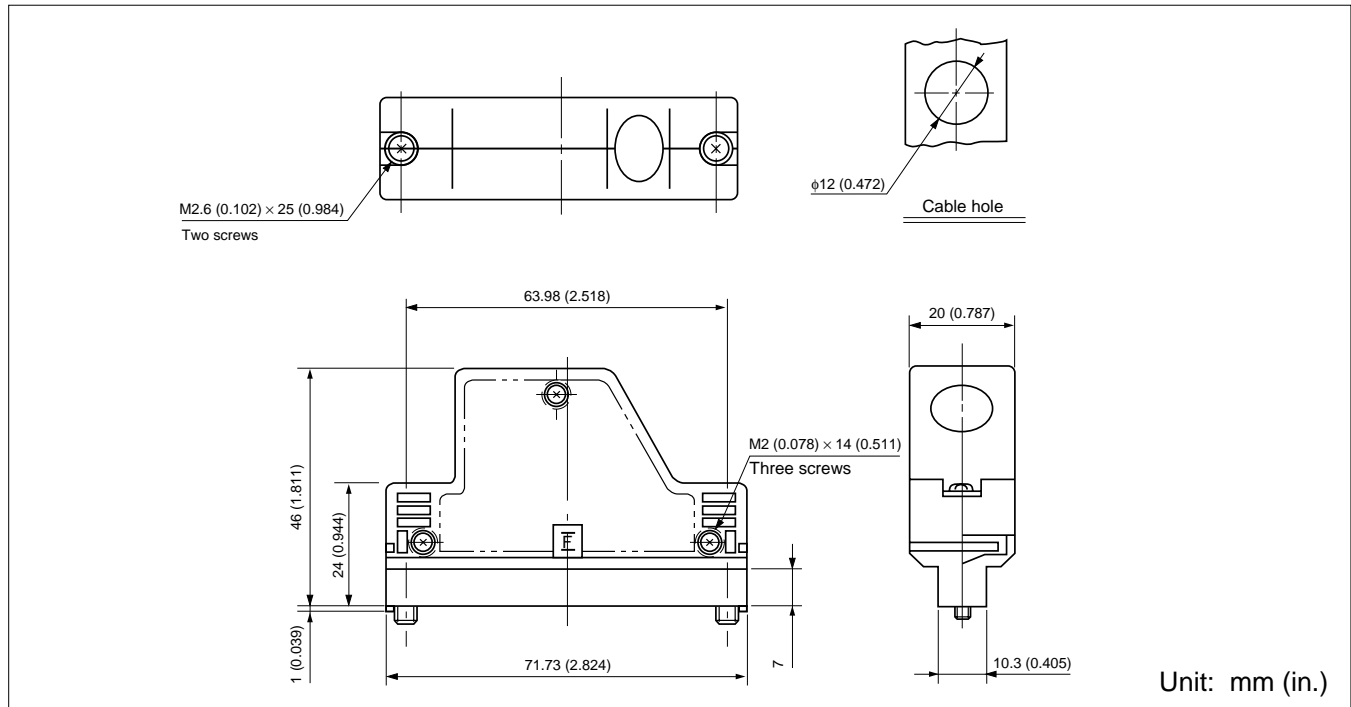

■ EXPLODED VIEW

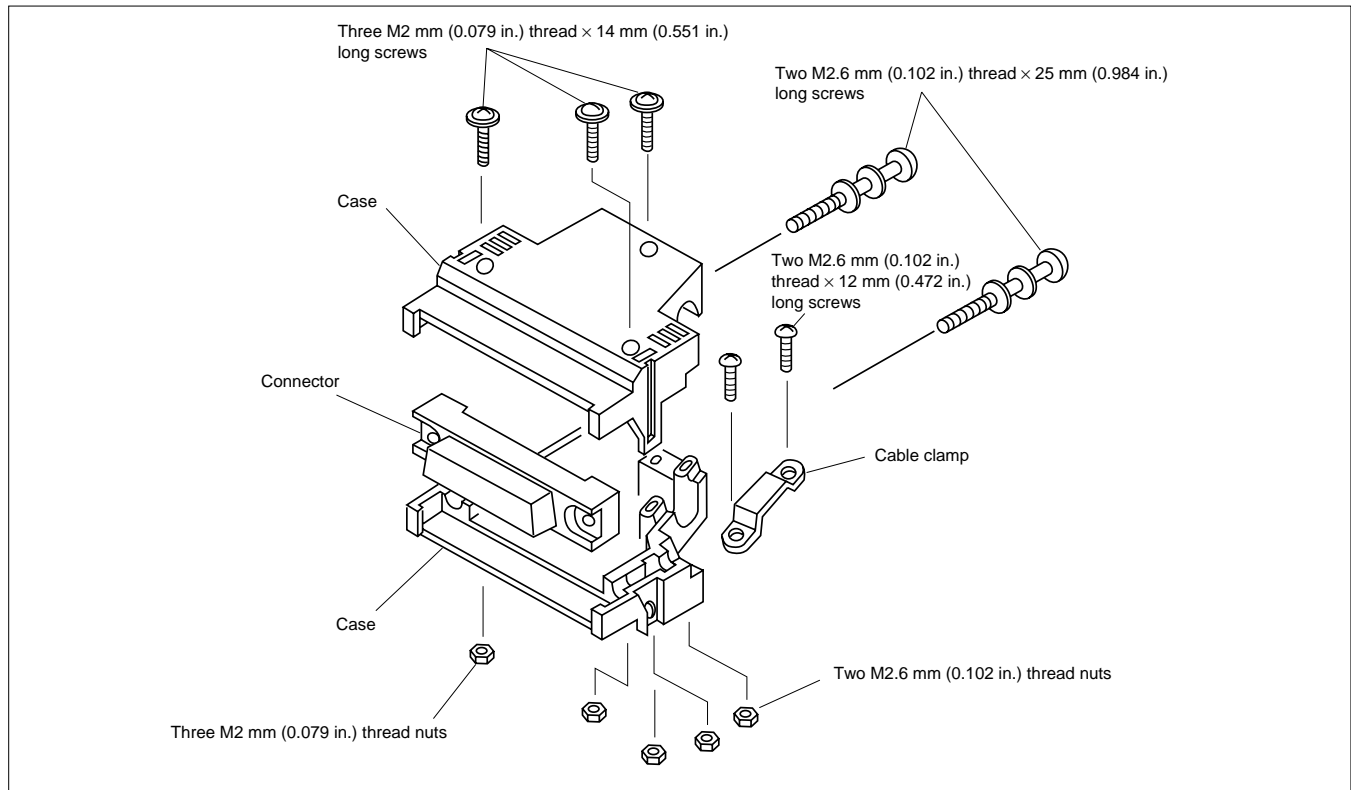

■ PART NUMBER

FCN-360C040-J1

FCN-360 Series

LOW PROFILE COVER (OBTUSE ANGLE CABLE -OUT) (TYPE J2)

■ DIMENSION

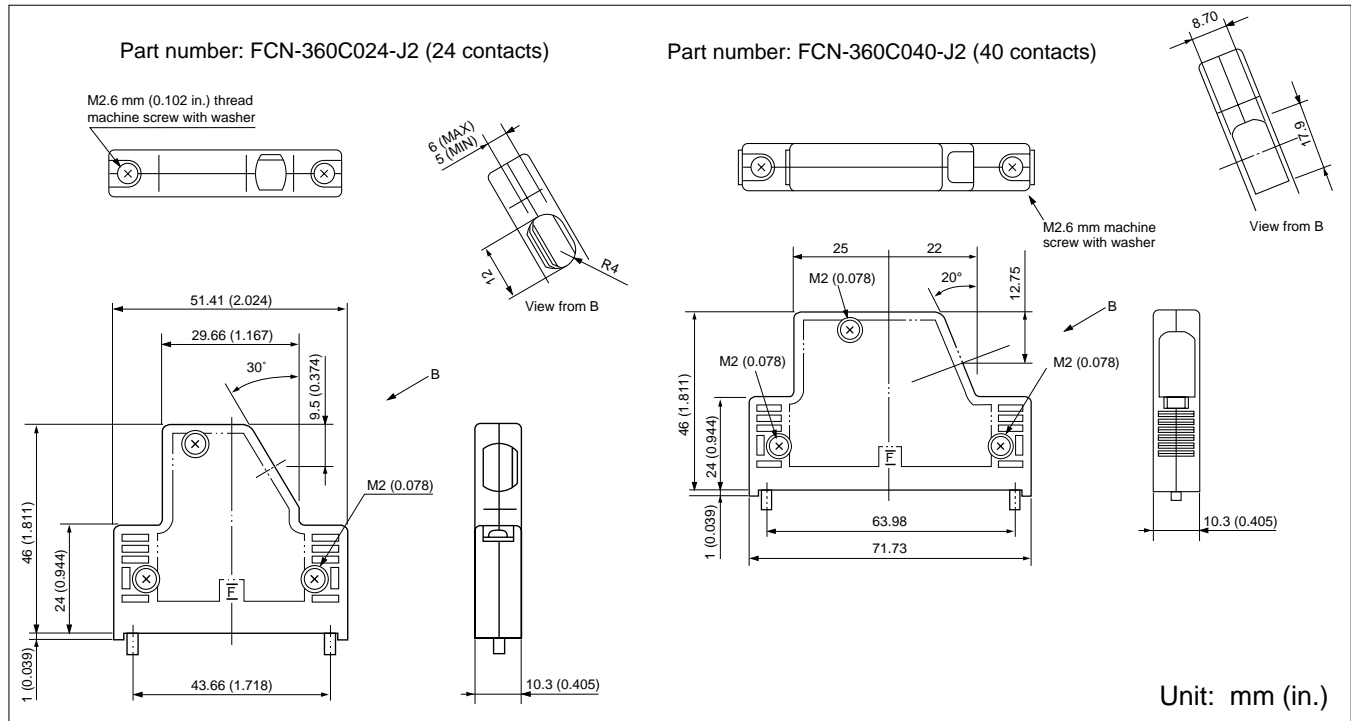

■ EXPLODED VIEW

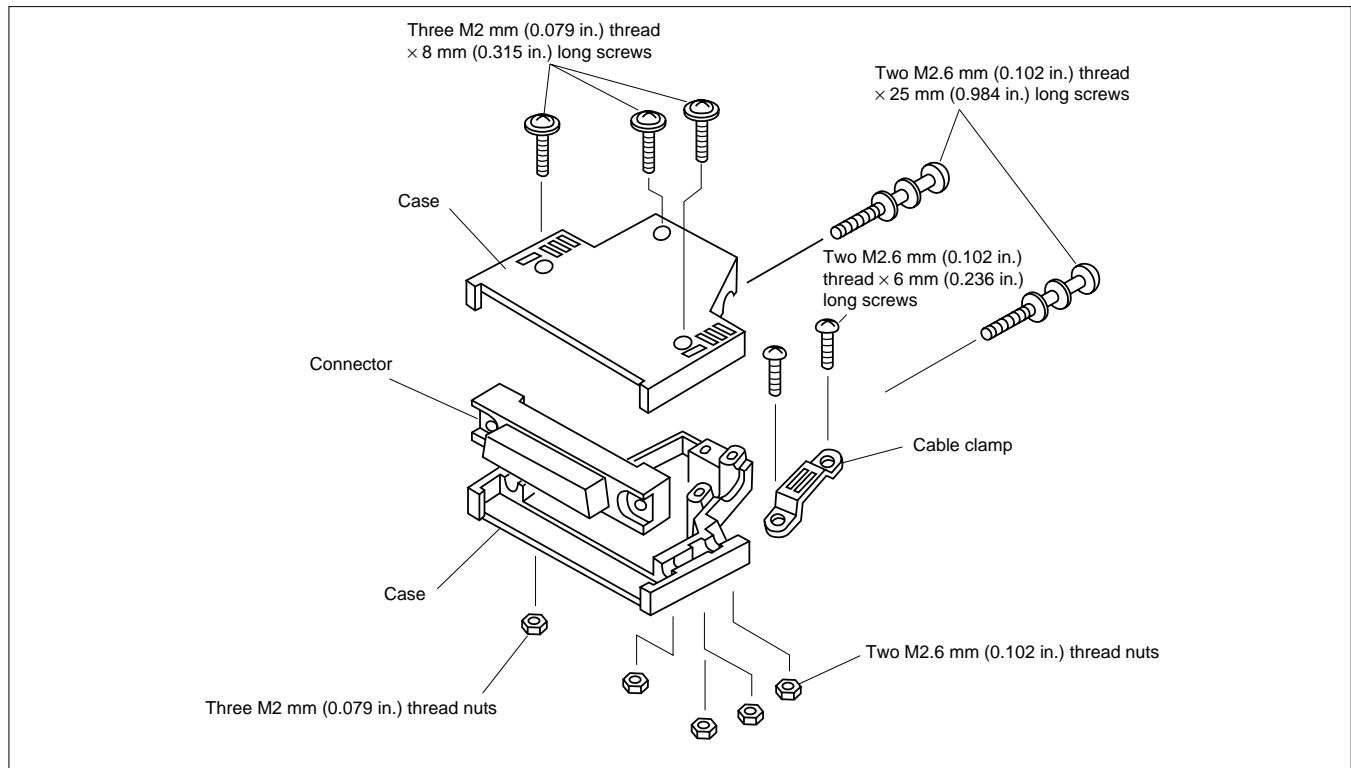

■ PART NUMBER

FCN-360C024-J2

FCN-360C040-J2

ACCESSORIES

■ MOUNTING SYLE

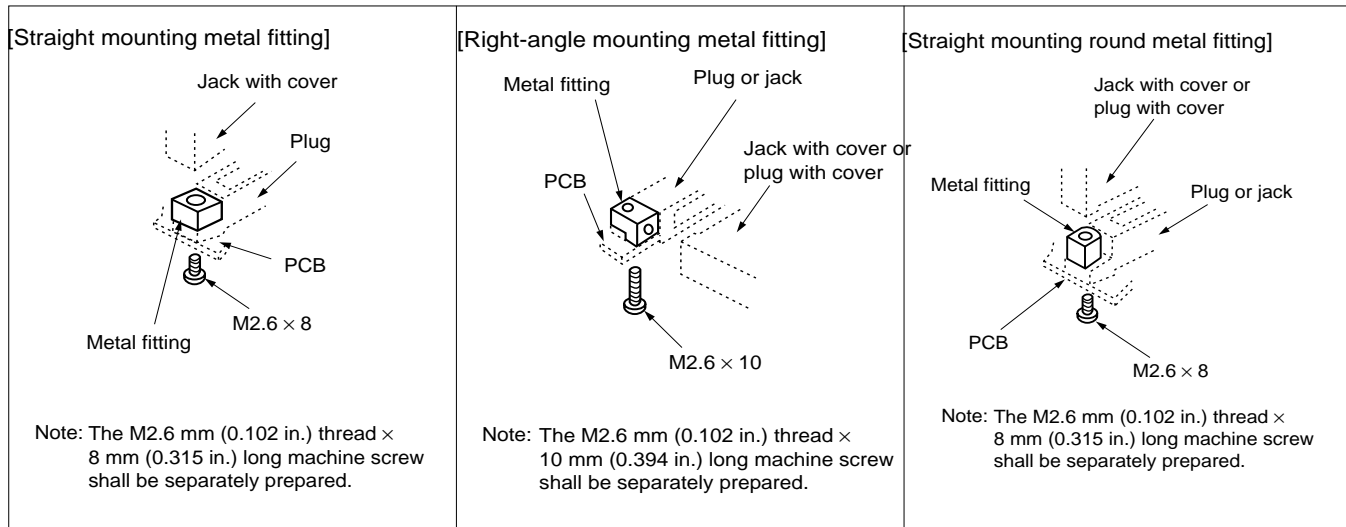

■ SELECTION OF METAL FITTINGS ACCORDING TO COMBINATION OF CONNECTORS AND COVERS

| Jack / Plug | | | Cover mounting side | | | | | | | | | |
|-----------------------------|------|---------------------------|---------------------|---------------|------------|---------------|------------|---------------|------------|---------------|------------|---------------|
| | | | 361J | | 362J | | 363J | | 364J | | 367J | |
| | | | With cover | Without cover | With cover | Without cover | With cover | Without cover | With cover | Without cover | With cover | Without cover |
| Metal fitting mounting side | 361P | Metal fitting part number | FCN-360A4 | FCN-360A5 | FCN-360A4 | FCN-360A5 | FCN-360A4 | FCN-360A5 | FCN-360A4 | FCN-360A5 | — | FCN-360A5 |
| | 362P | | FCN-360A1 | FCN-360A6 | FCN-360A1 | FCN-360A6 | FCN-360A1 | FCN-360A6 | FCN-360A1 | FCN-360A6 | — | FCN-360A6 |
| | 364P | | FCN-360A1 | FCN-360A6 | FCN-360A1 | FCN-360A6 | FCN-360A1 | FCN-360A6 | FCN-360A1 | FCN-360A6 | — | FCN-360A6 |
| | 365P | | FCN-360A2 | FCN-360A3 | FCN-360A2 | FCN-360A3 | FCN-360A2 | FCN-360A3 | FCN-360A2 | FCN-360A3 | — | FCN-360A3 |

| Jack / Plug | | | Cover mounting side | | | | | |
|-----------------------------|------|---------------------------|------------------------|---------------|------------|---------------|------------|---------------|
| | | | 361P | | 361P | | 364P | |
| | | | With cover | Without cover | With cover | Without cover | With cover | Without cover |
| Metal fitting mounting side | 361J | Metal fitting part number | FCN-360A4 | FCN-360A5 | — | FCN-360A7 | — | FCN-360A7 |
| | 362J | | FCN-360A4 | FCN-360A5 | — | FCN-360A7 | — | FCN-360A7 |
| | 363J | | FCN-360A4 | FCN-360A5 | — | FCN-360A7 | — | FCN-360A7 |
| | 364J | | FCN-360A4 | FCN-360A5 | — | FCN-360A7 | — | FCN-360A7 |
| | 365J | | FCN-360A10 (FCN-360A8) | FCN-360A9 | — | FCN-360A9 | — | FCN-360A9 |
| | 367J | | FCN-360A4 | FCN-360A5 | — | FCN-360A7 | — | FCN-360A7 |

Note: When the jack or plug without a cover (shaded part) is used, have M2.6 × 8 mm machine screws ready in order to tighten the connector.

■ SHAPES AND DIMENSIONS OF METAL FITTINGS

1. Straight Mounting Metal Fittings

| Shape | Part number | | FCN-360A1 | FCN-360A6 |
|-----------------------|-------------|--|-------------|-------------|
| | Symbol | | | |
| <p>Unit: mm (in.)</p> | A | | 5.3 (0.208) | 6.3 (0.248) |

2. Right-angle Mounting Metal Fittings

| Shape | Part number | | FCN-360A2 | FCN-360A3 |
|-----------------------|-------------|--|-----------|------------|
| | Symbol | | | |
| <p>Unit: mm (in.)</p> | B | | 3 (0.118) | 4 (0.157) |
| | C | | 9 (0.354) | 10 (0.393) |

| Shape | Part number | | FCN-360A8 | FCN-360A9 |
|-----------------------|-------------|--|--------------|--------------|
| | Symbol | | | |
| <p>Unit: mm (in.)</p> | B | | 5.3 (0.208) | 6.3 (0.248) |
| | C | | 13.3 (0.523) | 14.3 (0.526) |

| Symbol | Part number |
|-----------------------|-------------|
| | FCN-360A10 |
| <p>Unit: mm (in.)</p> | |

| Symbol | Part number |
|-----------------------|-------------|
| | FCN-360A11 |
| <p>Unit: mm (in.)</p> | |

3. Straight Mounting Round Metal Fittings

| Shape | Part number | | | |
|-----------------------|-------------|-------------|-------------|-------------|
| | Symbol | FCN-360A4 | FCN-360A5 | FCN-360A7 |
| <p>Unit: mm (in.)</p> | D | 7.1 (0.279) | 9.9 (0.389) | 8.1 (0.318) |

Fujitsu Components International Headquarter Offices

Japan

Fujitsu Component Limited
Gotanda-Chuo Building
3-5, Higashigotanda 2-chome, Shinagawa-ku
Tokyo 141, Japan
Tel: (81-3) 5449-7010
Fax: (81-3) 5449-2626
Email: promothq@ft.ed.fujitsu.com
Web: www.fcl.fujitsu.com

North and South America

Fujitsu Components America, Inc.
250 E. Caribbean Drive
Sunnyvale, CA 94089 U.S.A.
Tel: (1-408) 745-4900
Fax: (1-408) 745-4970
Email: marcom@fcai.fujitsu.com
Web: www.fcai.fujitsu.com

Europe

Fujitsu Components Europe B.V.
Diamantlaan 25
2132 WV Hoofddorp
Netherlands
Tel: (31-23) 5560910
Fax: (31-23) 5560950
Email: info.marketing@fceu.fujitsu.com
Web: www.fceu.fujitsu.com

Asia Pacific

Fujitsu Components Asia Ltd.
102E Pasir Panjang Road
#04-01 Citilink Warehouse Complex
Singapore 118529
Tel: (65) 375-8560
Fax: (65) 273-3021
Email: fcal@fcal.fujitsu.com
www.fcal.fujitsu.com

© 2001 Fujitsu Components America, Inc. All company and product names are trademarks or registered trademarks of their respective owners. Rev. 09/2001