

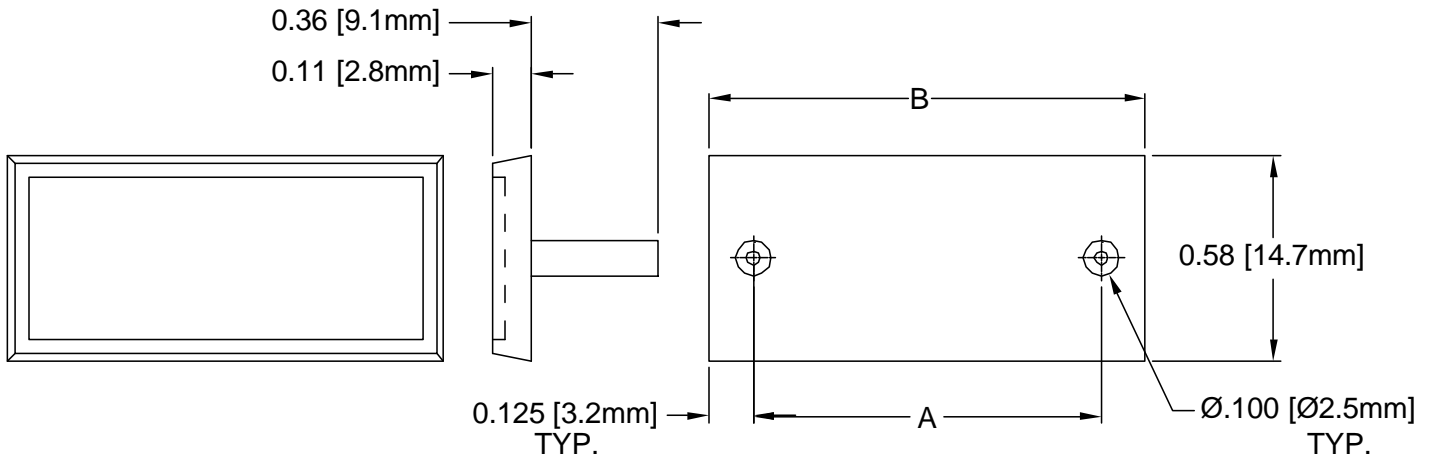

REV.	DESCRIPTION	DATE	APPROVED
B	Engineering Update w/o Changes	02/13/04	M. C.
C	Material Update	02/10/06	M. C.
D	Changed Material from 43-BK to 08-BK	06/27/07	M. C.



PART NO.	A	B	CLIP NO.
10-9	0.984 (25.0mm)	1.23 (31.2mm)	SSC-1
10-15	1.312 (33.3mm)	1.56 (39.6mm)	SSC-1
10-25	1.852 (47.0mm)	2.10 (53.3mm)	SSC-1
10-37	2.500 (63.5mm)	2.75 (69.9mm)	SSC-1
10-50	2.406 (61.1mm)	2.66 (67.6mm)	SSC-1

STANDARD TOLERANCE (UNLESS OTHERWISE SPECIFIED)		 4 THOMAS, IRVINE, CA. 92618 TEL: (949) 951-8808 FAX: (949) 951-3974			
DECIMALS	ANGULAR				
.X ±.1	X° ± 1°	TITLE: CONNECTOR CUT-OUT COVER			
.XX ±.01					
.XXX ±.005		DESIGNED: David Green	DATE: 05/05/03	PART NO: 10-XX	REVISION: D
		CHECKED: M. Chen	DATE: 05/05/03	CAGE CODE : 32559	SHEET # 1 OF 1
CAD GENERATED DOCUMENT, DO NOT MEASURE DRAWING.					

2. MATERIAL: ABS, 94V-0, BLACK. BIVAR MATERIAL CODE 08-BK.

GE PLASTICS ABS, CYCOLAC KJW, 94V-0, BLACK

1. GENERAL SPECIFICATIONS: BIVAR MOLDED COMPONENT SPECIFICATION BV00-E101.