

D-SUB HARDWARE ACCESSORIES

Slide lock with holding bolt – Mounting for 9-50 pos.

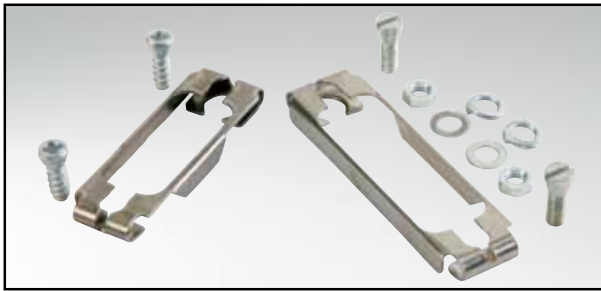

RoHS compliant – CSA listed, File No.: LR 115000-1 – UL listed, File No.: E202784

DESCRIPTION

- Slide lock set in two designs:
 - Type 3: 1 frame, 2 screws 4-40 UNC, 2 grommets, 2 spring rings, 2 4-40 UNC nuts
 - Type 4: 1 frame, 2 4-40 UNC screws, 2 grommets, 2 spring rings, 2 4-40 UNC nuts
- Holding bolt set consists of 2 hex bolts, 2 grommets, 2 spring rings, 2 nuts
- Bulk packaged

PRODUCT DRAWING

Type 3

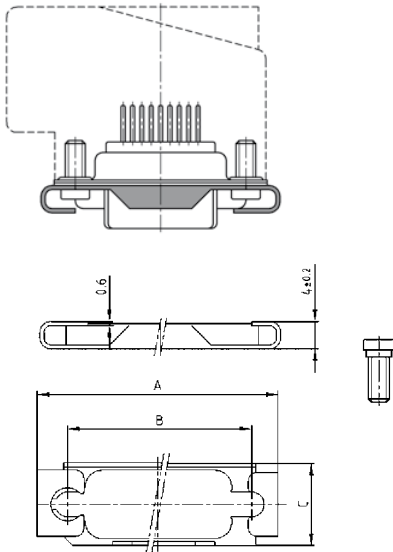

No. of pos.	A	B	C
09	35.00	27.40	12.00
15	43.30	35.70	11.50
25	57.00	49.40	12.00
37	74.40	65.90	12.00
50	72.00	63.50	15.00

Type 4

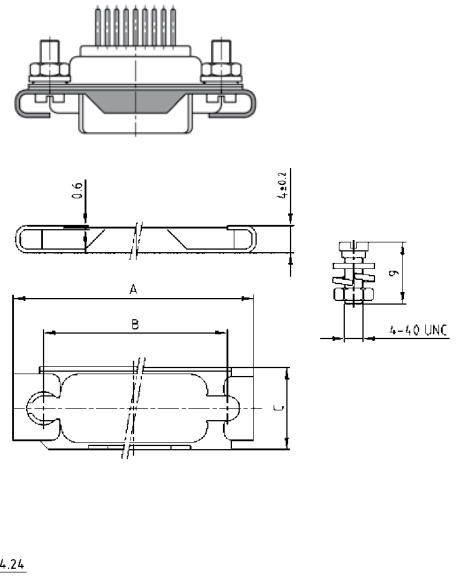

holding bolt for slide lock

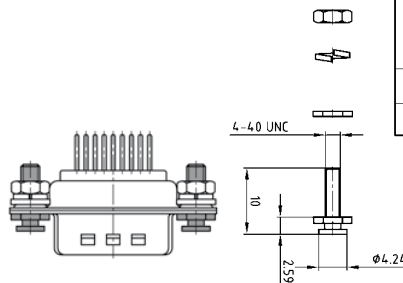

ORDER DATA

SLIDE LOCK TYPE 3

No. of pos.	Design	Part Number
09	Slide lock set type 3	160 X 10159 X
15	Slide lock set type 3	160 X 10169 X
25	Slide lock set type 3	160 X 10179 X
37	Slide lock set type 3	160 X 10189 X
50	Slide lock set type 3	160 X 10199 X

SLIDE LOCK TYPE 4

No. of pos.	Design	Part Number
09	Slide lock set type 4	160 X 10689 X
15	Slide lock set type 4	160 X 10699 X
25	Slide lock set type 4	160 X 10709 X
37	Slide lock set type 4	160 X 10719 X
50	Slide lock set type 4	160 X 10729 X

HOLDING BOLT FOR SLIDE LOCK

No. of pos.	Design	Part Number
09 - 50	Slide lock type 3 and type 4	160 X 10209 X