

# Customer Information Sheet

DRAWING No.: C90-3102RXXSX-XX

SHEET 2 OF 2

IF IN DOUBT - ASK

©

NOT TO SCALE

THIRD ANGLE PROJECTION

ALL DIMENSIONS IN mm

## CONTACT LAYOUT (SHOWN LOOKING AT THE MATING FACE)

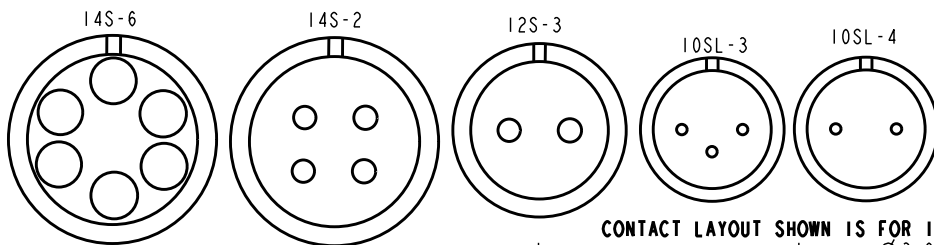

ORDER CODE: **C90-3102RXXXX-XX**

SHELL SIZE (CONTACT LAYOUT)  
10SL-3, 10SL-4, 12S-3, 14S-2  
14S-6

CONTACT GENDER  
P - MALE  
S - FEMALE

CONTACT LAYOUT SHOWN IS FOR ILLUSTRATION ONLY.

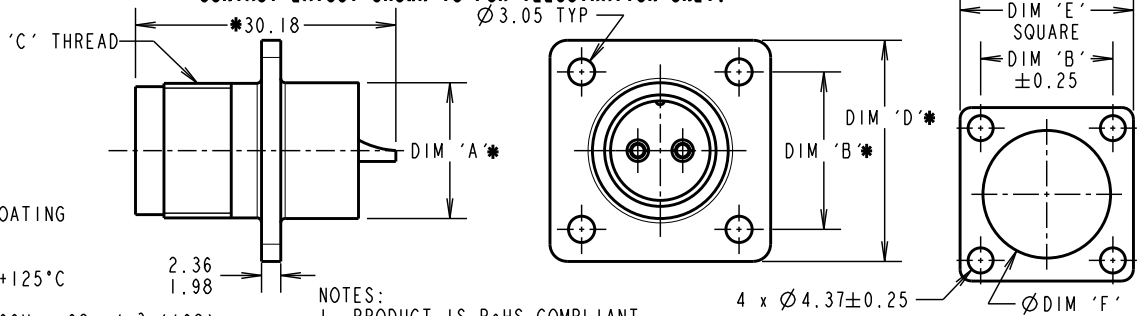

### SPECIFICATIONS:

**MATERIAL:**  
SHELL: ALUMINIUM ALLOY  
INSULATOR: SYNTHETIC RUBBER  
GASKET: SYNTHETIC RUBBER  
CONTACT COPPER ALLOY

**FINISH:**  
SHELL: ZINC WITH BLACK CHROMATE COATING  
CONTACT: SILVER

**ENVIRONMENTAL:**  
OPERATING TEMPERATURE: -55°C TO +125°C

**MECHANICAL:**  
VIBRATION SENSITIVITY: 10Hz TO 500Hz, 98mm/s<sup>2</sup> (10G)  
SHOCK SEVERITY: 490m/s<sup>2</sup> (50G) FOR 11ms  
WATER RESISTANCE (SEALING): 1.8m FOR 48HRS, EXCEEDS IP67

**ELECTRICAL:**  
CURRENT RATING: 13A  
VOLTAGE RATING: 10SL & 12S SHELL SIZES: 500V AC, 700V DC  
14S SHELL SIZE: 200V AC, 250V DC  
VOLTAGE PROOF: 10SL & 12S: 2,000V AC  
14S: 1,000V AC  
INSULATION RESISTANCE: 5,000MΩ MIN.  
FOR MECHANICAL/ELECTRICAL REQUIREMENTS,  
SEE COMPONENT SPECIFICATION C045XX (LATEST ISSUE)

### NOTES:

1. PRODUCT IS RoHS COMPLIANT
2. PRODUCT IS PACKED IN BAGS WITH GASKET.
3. RECOMMENDED WIRE SIZE 16-22 AWG
4. RECOMMENDED PANEL CUT-OUT FOR SHELL SIZE 10SL & 12S = Ø20.62 AND FOR SHELL SIZE 14S = Ø23.83.

SHELL SIZE	DIM 'A'	DIM 'B'	THREAD 'C'	DIM 'D'	DIM 'E' +0.4 -0.0	DIM 'F' +0.4 -0.0
10SL	Ø15.75	18.25	5/8-24UNEF	25.65	25.40	Ø15.87
12S	Ø17.17	20.62	3/4-20UNEF	28.02	27.80	Ø19.05
14S	Ø18.92	23.02	7/8-20UNEF	30.40	30.17	Ø22.22

RA	4	22.02.11	11153
NAME	ISS.	DATE	C/NOTE
APPROVED: R. ADDE			
CHECKED: M.G.PLESTED			
DRAWN: R. ADDE			
CUSTOMER REF.:			
ASSEMBLY DRG:			

## HARWIN

HARWIN USA  
TEL: 603 893 5376  
FAX: 603 893 5396  
mis@harwin.com

HARWIN Europe (UK)  
TEL: 023 9231 4545  
FAX: 023 9231 4590  
mis@harwin.co.uk

HARWIN Asia  
TEL: +65 6 779 4909  
FAX: +65 6 779 3868  
mis@harwin.com.sg

THIS DRAWING AND ANY INFORMATION OR DESCRIPTIVE MATTER SET OUT HEREON ARE CONFIDENTIAL AND COPYRIGHT PROPERTY OF THE HARWIN GROUP AND MUST NOT BE DISCLOSED, LOANED, COPIED OR USED FOR MANUFACTURING, TENDERING OR FOR ANY OTHER PURPOSE WITHOUT THEIR WRITTEN PERMISSION.

**TOLERANCES**  
X. = ±1mm  
X.X = ±0.25mm  
X.XX = ±0.10mm  
X.XXX = ±0.01mm  
ANGLES = ±5°  
UNLESS STATED

**MATERIAL:**  
SEE ABOVE

**FINISH:** SEE ABOVE

**S/AREA:** mm<sup>2</sup>

**TITLE:**  
PANEL MOUNT CONNECTOR

**DRAWING NUMBER:**  
C90-3102RXXSX-XX

SHT 2 OF 2