

ACTUAL SIZE

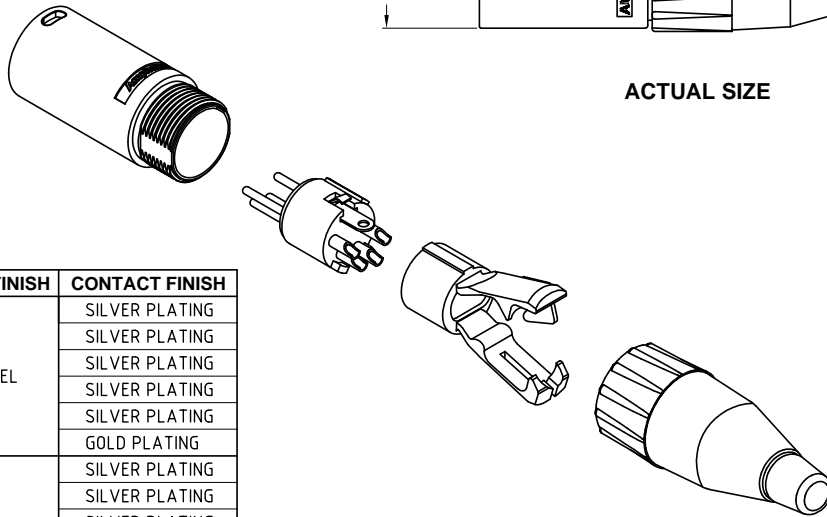

CAT P/No.	SHELL FINISH	CONTACT FINISH
AC3MJ	NICKEL	SILVER PLATING
AC3MMJ		SILVER PLATING
AC4MJ		SILVER PLATING
AC5MJ		SILVER PLATING
AC6AMJ		SILVER PLATING
AC7MJ		GOLD PLATING
AC3MBJ	BLACK	SILVER PLATING
AC3MMBJ		SILVER PLATING
AC4MBJ		SILVER PLATING
AC5MBJ		SILVER PLATING
AC6AMBJ		SILVER PLATING
AC7MBJ	GOLD PLATING	

UNLESS OTHERWISE SPECIFIED TOLERANCE TO BE		THIS DOCUMENT IS THE PROPERTY OF AMPHENOL AUSTRALIA PTY. LTD. NO PART THEREOF MAY BE REPRODUCED AND USED WITHOUT THE PRIOR WRITTEN CONSENT OF THE OWNER.		0	FIRST ISSUE	L.V	04-04-06	----
LINEAR	ANGULAR	CAD FILE:	55010371000110	DRN:	L.V	DATE:	04-04-06	TITLE:
X ± 0.5	X° ± 1°	MATL:	REFER TO COMPONENT	CKD:	M.N.H	DATE:	01-05-06	AC** J LINE CONNECTOR CUSTOMER DWG Amphenol <small>Amphenol Australia Pty Ltd, 2 Fieways Blvd, Keysborough, Vic 3173</small>
X.XX ± 0.1	X°X' ± 30"	FINISH:	REFER TO COMPONENT	APP'D:	P.M	DATE:	01-05-06	
BREAK ALL SHARP EDGES AND REMOVE ALL BURRS		DO NOT SCALE		SCALE: 1:1 UOS		PART No: REFER TO CHART		SIZE: A4
DIMENSIONS IN MILLIMETRES		THIRD ANGLE PROJECTION		DRAWING NO:		55010371-000-1		SHEET 1 OF 1