

features

- Fixed metal film resistor available (specify "SPRX")
- Flameproof silicone coating equivalent to (UL94V0)
- High reliability performance
- Suitable for automatic machine insertion
- Marking: Light green body color
Color-coded bands on 1/2W - 1W
Alpha-numeric black marking on 2W - 5W
- Products with lead-free terminations meet EU RoHS and China RoHS requirements

dimensions and construction

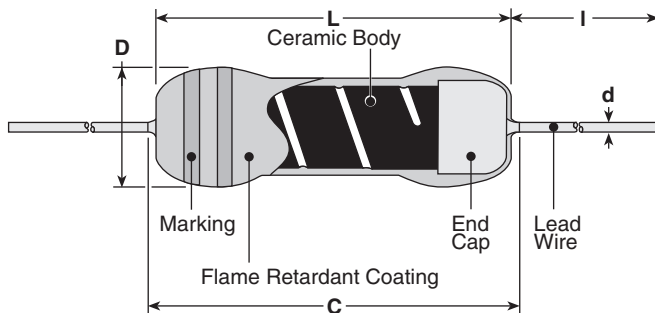

Type	Dimensions inches (mm)				
	L	C (max.)	D	d nominal	I
SPR1/4 SPRX1/4	.13±.012 (3.3±0.3)	.138 (3.5)	.067±.012 (1.7±0.3)	.018 (0.45)	.787 Min. (20.0 Min.)
SPR1/2 SPRX1/2	.244±.02 (6.2±0.5)	.280 (7.1)	.098±.02 (2.5±0.5)	.024 (0.6)	.945 Min. (24.0 Min.)
SPR1 SPRX1	.354±.039 (9.0±1.0)	.437 (11.1)	.138±.02 (3.5±0.5)	.031 (0.8)	
SPR2 SPRX2	.472±.039 (12.0±1.0)	.591 (15.0)	.165±.031 (4.2±0.8)		1.18±.118 (30.0±3.0)
SPR3 SPRX3	.610±.039 (15.5±1.0)	.709 (18.0)	.236±.039 (6.0±1.0)	1.50±.118 (38.0±3.0)	
SPR5 SPRX5	.965±.039 (24.5±1.0)	1.10 (28.0)	.354±.039 (9.0±1.0)		

ordering information

New Part #	SPR	1/2	C	T52	R	103	J
Type	SPR SPRX	Power Rating	Termination Material	Taping and Forming	Packaging	Nominal Resistance	Tolerance
		1/4: 0.25W 1/2: 0.5W 1: 1W 2: 2W 3: 3W 5: 5W	C: SnCu	Axial: T26, T52, T521, T631 Stand-off Axial: L52, L521, L631 Radial: VT, VTP, VTE, GT L, U, M Forming	A: Ammo R: Reel	±2%, ±5%: 2 significant figures + 1 multiplier "R" indicates decimal on value <10Ω ±1%: 3 significant figures + 1 multiplier "R" indicates decimal on value <100Ω	F: ±1% G: ±2% J: ±5%

For further information on packaging, please refer to Appendix C.

applications and ratings

Part Designation	Power Rating @ 70°C	Minimum Dielectric Withstanding Voltage	T.C.R. (ppm/°C) ±350	T.C.R. (ppm/°C) +350 to -600	Resistance Range E-24 (F±1%, G±2%)	Resistance Range E-24 (J±5%)	Absolute Maximum Working Voltage	Absolute Maximum Overload Voltage	Operating Temperature Range
SPR1/4	0.25W	300V	2.2Ω - 10KΩ	—	—	2.2Ω - 10KΩ	250V	500V	-55°C to +200°C
SPR1/2	0.5W	500V	2.2Ω - 91KΩ	≥100KΩ	10Ω - 100KΩ	2.2Ω - 240KΩ	400V	800V	
SPR1	1W					2.2Ω - 330KΩ	500V	1000V	
SPR2	2W	700V	2.2Ω - 110KΩ	≥120KΩ	2.2Ω - 510KΩ				
SPR3	3W		2.2Ω - 130KΩ	≥150KΩ	2.2Ω - 750KΩ				
SPR5	5W	800V	2.2Ω - 220KΩ	≥240KΩ	2.2Ω - 1.0MΩ	600V	1200V		
SPRX1/4	0.25W	300V	0.1Ω - 2.0Ω	—	—	0.1Ω - 2.0Ω	$E = \sqrt{P \times R}$	E x 2.5	
SPRX1/2	0.5W	500V							
SPRX1	1W								
SPRX2	2W								
SPRX3	3W								
SPRX5	5W	800V							

environmental applications

Derating Curve

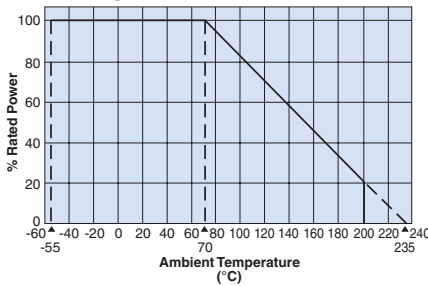

Surface Temperature Rise

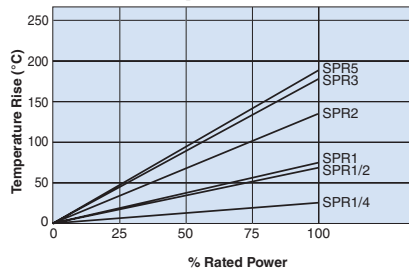

Load Life @ 70°C, 1000 Hr

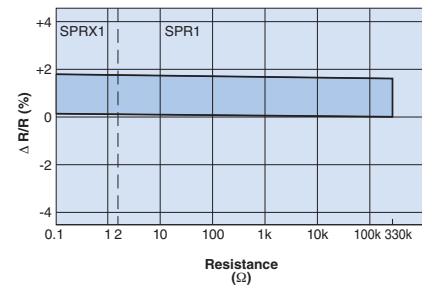

Performance Characteristics

Parameter	Requirement ΔR ±(% + 0.05Ω)		Test Method
	Limit	Typical	
Resistance	Within specified tolerance	—	Measuring points are at 10mm ±1mm from the end cap.
T.C.R.	Within specified T.C.R.	—	Room temperature +100°C
Overload (Short time)	±(1%+0.1Ω)	±0.5%	Rated voltage x 2.5 or max. overload voltage for 5 seconds, whichever is lower
Resistance to Solder Heat	±1%	±0.5%	260°C ±5°C, 10 seconds ± 1 second
Terminal Strength	No lead-coming off and loose terminals	—	Twist 360°C, 5 times
Rapid Change of Temperature	±1%	±0.5%	-55°C (30 minutes), +125°C (30 minutes), 5 cycles
Moisture Resistance	±(3%+0.1Ω):1/4W-2W ±(5%+0.1Ω):3W,5W	1.5: 1/4W-2W 2.5: 3W, 5W	40°C ± 2°C, 90 - 95% RH, 1000 hours, 1.5 hr ON, 0.5 hr OFF cycle
Endurance at 70°C	±(3%+0.1Ω):1/4W-2W ±(5%+0.1Ω):3W,5W	1.5: 1/4W-2W 2.5: 3W, 5W	70°C ± 2°C, 1000 hours, 1.5 hr ON, 0.5 hr OFF cycle
High Temperature Exposure	±(2% +0.1Ω)	±1%	-125°C, 100 hours
Resistance to Solvent	No abnormality in appearance. Marking shall be easily legible	—	Ultrasonic washing with isopropyl alcohol for 2 minutes. Power: 0.3W/cm ³ , f: 28kHz, Temp: 35°C ±5°C
Flame Retardant	No evidence of flaming or self-flaming	—	Flame test: the test flame shall be applied and removed for each 15 seconds respectively to repeat the cycle 5 times. Overload flame retardant: power (AC) corresponding to 2, 4, 8, 16 and 32 times the power rating shall be applied for each 1 minute until disconnection occurs. However the applied voltage shall not exceed the value of 4 times of the maximum operating voltage

Specifications given herein may be changed at any time without prior notice. Please confirm technical specifications before you order and/or use.

12/29/08