



Features

- Long life carbon element
- Assortment of resistance tapers
- 100 mm travel length
- Touch sense lever
- PC terminals or snap-in connector option



PSM Series Motorized Slide Potentiometer

Electrical Characteristics

Standard Resistance Range 1K ohms to 1 megohm
 Standard Resistance Tolerance... $\pm 20\%$
 End Resistance 20 ohms max.
 Insulation Resistance @ 250 VDC
 100 megohms min.
 Dielectric Withstanding Voltage
 250 VAC
 Standard Taper Linear, Audio
 Power Rating - Linear 0.5 watt
 Power Rating - Audio 0.25 watt
 Slider Noise 47 mV max.
 Touch Sense Track
 Conductive Resistance
 Snap-in Connector 2 ohms max.
 PC Terminal
 TR > 30k ohms... 0.1 % of TR max.
 TR \leq 30k ohms 30 ohms max.

Environmental Characteristics

Operational Life 100,000 cycles
 TR Shift $\pm 15\%$
 Operating Temperature Range
 -10 °C to +55 °C
 Resistance to Solder Heat $\pm 5\%$

Mechanical Characteristics

Mechanical Travel
 See Product Dimensions
 Operating Force 30-130 gf
 Stop Strength 5 kgf min.
 Shaft Wobble.. 2(2 x L/25) mm p-p max.
 Soldering Condition
 Manual 300 °C ± 5 °C for 3 sec.
 Wave 260 °C ± 5 °C for 5 sec.
 Wash Not recommended

Motor Drive Characteristics

Rated Voltage 10 VDC
 Operating Voltage Supply .. 6 to 11 VDC
 Starting Current 800 mA max.
 Starting Force @ 10 VDC 20 gf
 Lever Speed @ 10 VDC
 20 mm/0.1 sec.

Product Dimensions

PC Terminals

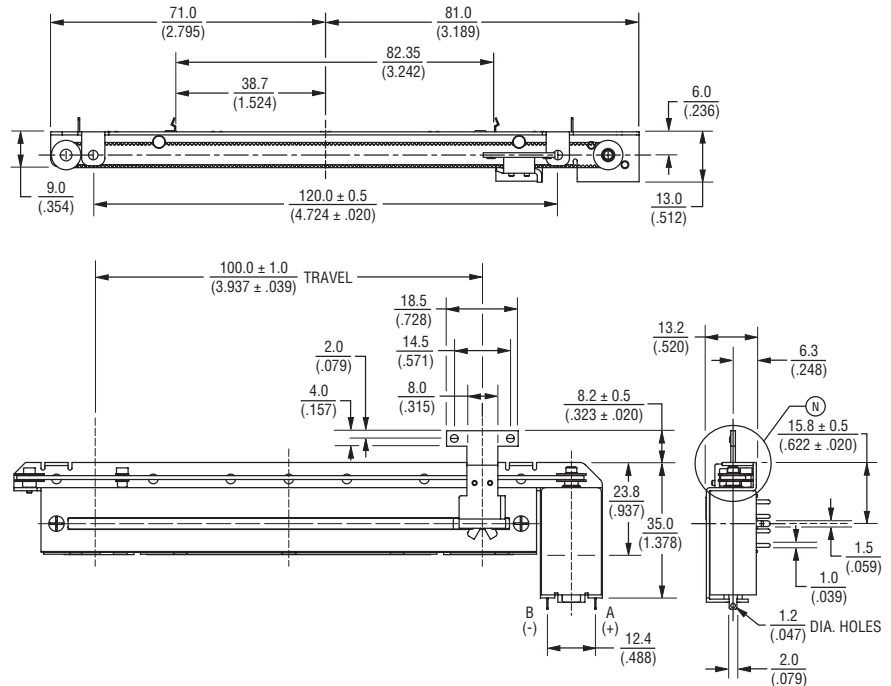

Mounting Hole Detail

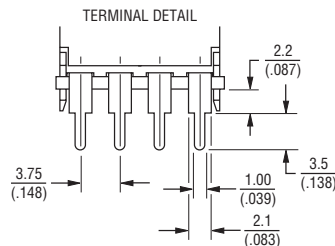
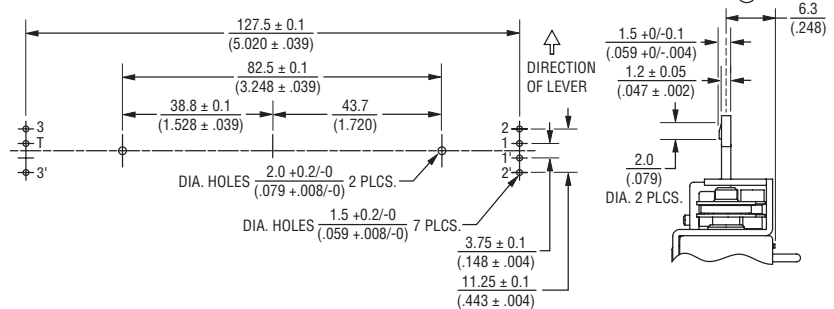

DIMENSIONS: $\frac{\text{MM}}{\text{(INCHES)}}$

*RoHS Directive 2002/95/EC Jan 27, 2003 including Annex.
 Specifications are subject to change without notice.
 Customers should verify actual device performance in their specific applications.

Applications

- Audio mixing consoles
- Broadcast mixing consoles

PSM Series Motorized Slide Potentiometer **BOURNS®**

Product Dimensions

Snap-in Connector

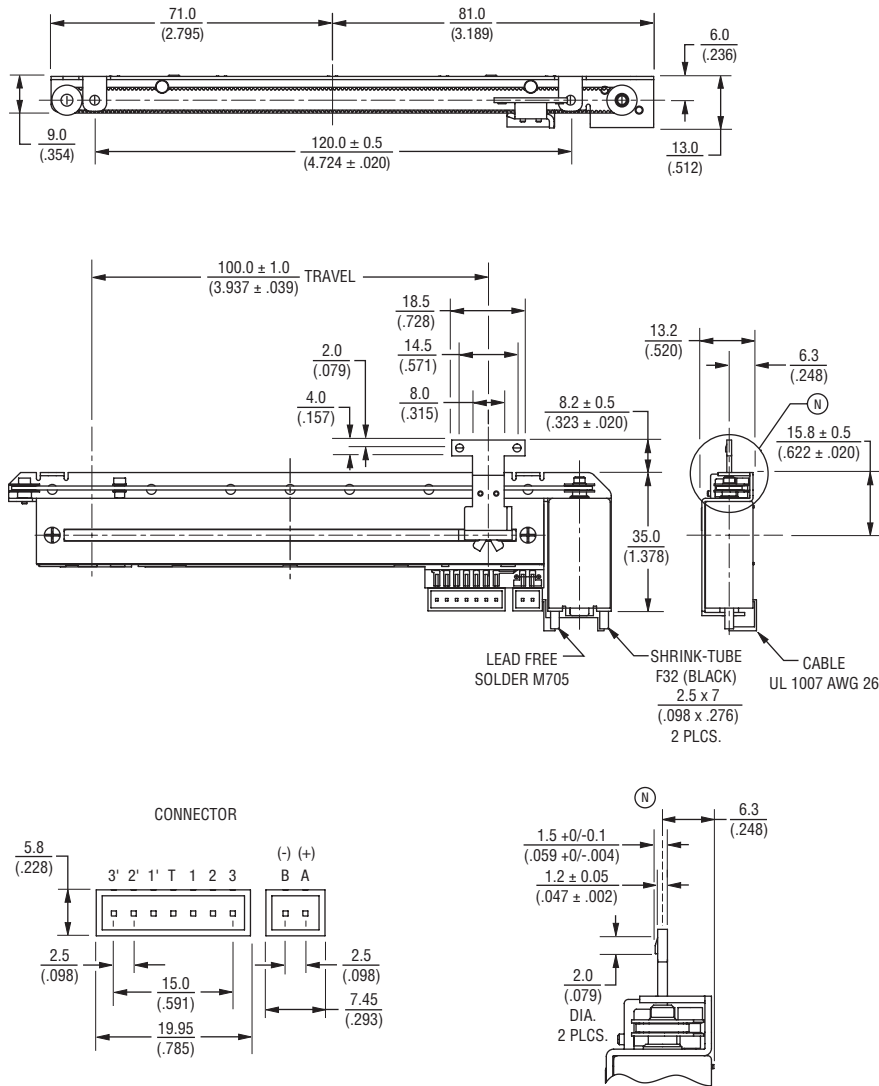

DIMENSIONS: $\frac{MM}{(INCHES)}$

Tapers

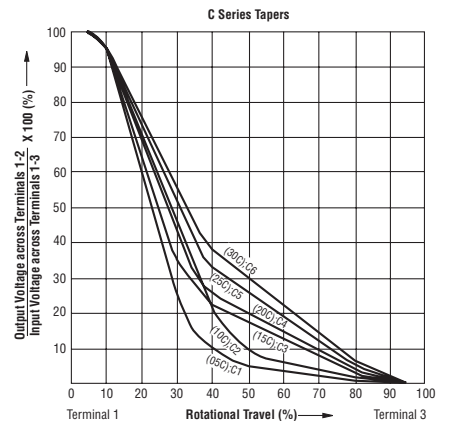
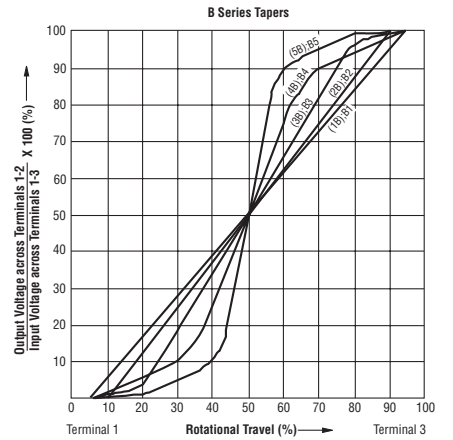
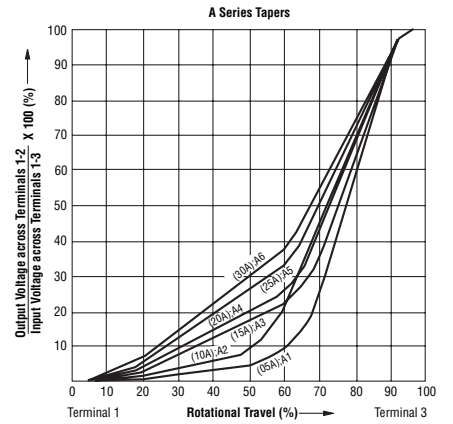

Specifications are subject to change without notice. Customers should verify actual device performance in their specific applications.

PSM Series Motorized Slide Potentiometer

BOURNS®

Schematics

Motor

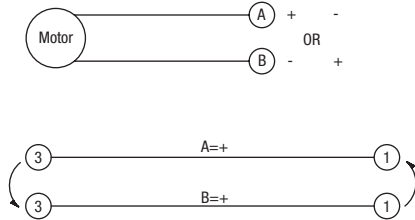

Line Track



Touch Sense Track

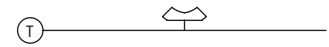

Servo Track



Standard Resistance Table

Resistance (Ohms)	Resistance Code
1,000	102
2,000	202
5,000	502
10,000	103
20,000	203
50,000	503
100,000	104
200,000	204
500,000	504
1,000,000	105

How To Order

PSM 01 - 08 2 A - 103 B2

Model Number _____
 Designator _____
 PSM = Motorized Slide Potentiometer
 Length of Travel _____
 01 = 100 mm
 Lever Length _____
 08 = 8.2 mm
 Terminal Type _____
 1 = PC Terminals
 2 = Snap-in Connector
 Lever End Style _____
 A = Metal Lever (Refer to Drawing)
 Resistance Code _____
 (See Standard Resistance Table)
 Resistance Taper (See Taper Charts) _____
 Taper Series followed by Curve Number

Servo Track Output Chart

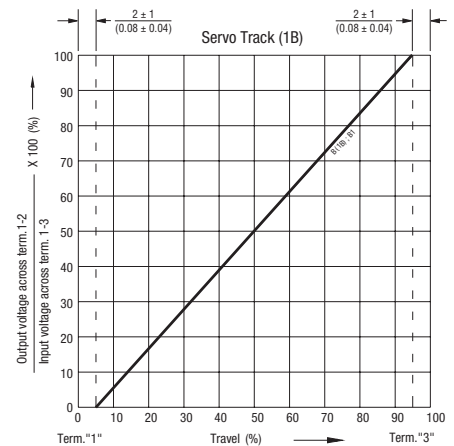

BOURNS®

Asia-Pacific: Tel: +886-2 2562-4117 • Fax: +886-2 2562-4116

Europe: Tel: +41-41 768 5555 • Fax: +41-41 768 5510

The Americas: Tel: +1-951 781-5500 • Fax: +1-951 781-5700

www.bourns.com

REV. 01/11

Specifications are subject to change without notice.
 Customers should verify actual device performance in their specific applications.