

THIS DOCUMENT CONTAINS PROPRIETARY DATA OF POLARIS INDUSTRIAL ENTERPRISES, INC. NO DISCLOSURE, REPRODUCTION, OR USE OF ANY PART THERE OF MAY BE MADE EXCEPT BY WRITTEN PERMISSION.

REV.	BY	DATE	APPRVL.	P/N
C	BT	10-8-98	BT	M/46
				REVISED CHART

SPECIFICATIONS

NUMBER OF TURNS ----- UP TO 20
 NUMBER OF GRADUATIONS ----- 100 PER TURN
 SHAFT MTG. DIA. ----- SEE CHART
 LOCK DEVICE ----- OVER THE CENTER ACTION
 OPERATING TEMPERATURE ----- -30°C TO +60°C

MODEL	MATCHING SHAFT SIZE	COLOR	LOCK
MF46N-1/8	1/8	SATIN (WHITE NUMBERS)	
MF46N-1/4	1/4	SATIN (WHITE NUMBERS)	NO
MF46N-6MM	6MM	SATIN (WHITE NUMBERS)	
MFA46N-1/8	1/8	BLACK (WHITE NUMBERS)	NO
MFA46N-1/4	1/4	BLACK (WHITE NUMBERS)	
MFA46N-6MM	6MM	BLACK (WHITE NUMBERS)	
MF46L-1/8	1/8	SATIN (WHITE NUMBERS)	
MF46L-1/4	1/4	SATIN (WHITE NUMBERS)	YES
MF46L-6MM	6MM	SATIN (WHITE NUMBERS)	
MFA46L-1/8	1/8	BLACK (WHITE NUMBERS)	YES
MFA46L-1/4	1/4	BLACK (WHITE NUMBERS)	
MFA46L-6MM	6MM	BLACK (WHITE NUMBERS)	

TOLERANCES
 XX = +/- .010" FRACT. = +/- 1/64"
 XXX = +/- .005" ANGLES = +/- 1/2"
 ALL SPECIFICATIONS SUBJECT TO CHANGE WITHOUT NOTICE

SCALE	DATE: 8-6-86
NONE	BY
APPR'D	BT
CODE IDENT: 19477	

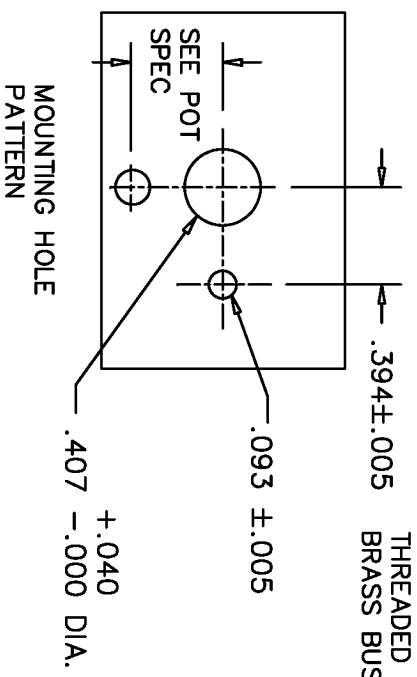
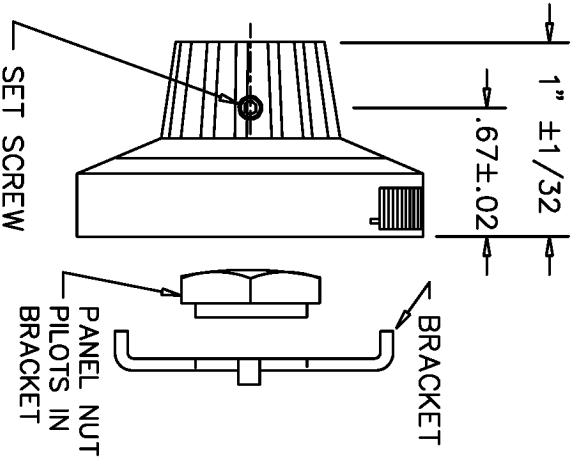
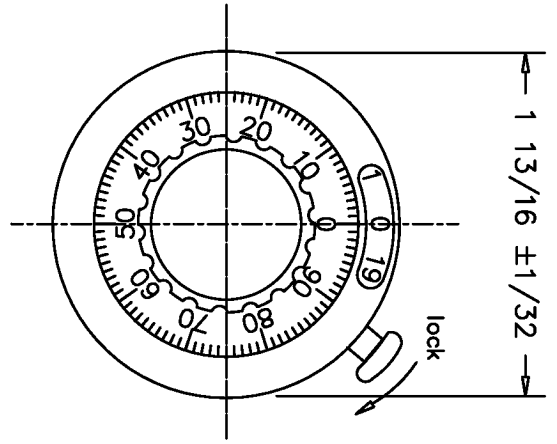

ETI SYSTEMS
 CARLSBAD
 CALIFORNIA

TITLE
 CONCENTRIC
 TURNS
 COUNTING
 DIAL

PART NO.
 MF46