

### features

- Surface mount
- Flat top suitable for high speed pick-and-place components
- Excellent high frequency applications
- High Q factors and self-resonant frequency values
- Marking: Black body color with white marking (0603, 0805, 1008)  
White body color with no marking (0402)
- Products with lead-free terminations meet EU RoHS requirements

### dimensions and construction

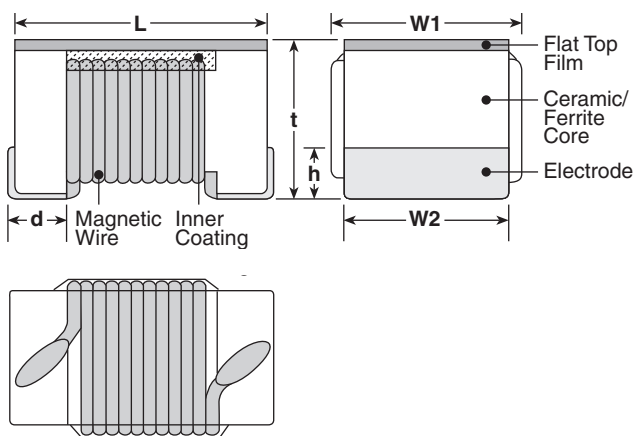

Size Code	Dimensions inches (mm)					
	L	W1	W2	t	h	d
KQT0402	.039±.004 (1.0±0.1)	.02±.004 (0.5±0.1)	.02±.004 (0.5±0.1)	.022±.004 (0.55±0.1)	.006±.004 (0.15±0.1)	.01±.004 (0.25±0.1)
KQ0603	.063±.004 (1.6±0.1)	.039±.004 (1.0±0.1)	.033±.004 (0.85±0.1)	.035±.004 (0.9±0.1)	.01±.006 (0.25±0.15)	.014±.004 (0.35±0.1)
KQ0805	.079±.008 (2.0±0.2)	.059±.008 (1.5±0.2) (3.3nH-390nH)	.053±.004 (1.35±0.1)	.051±.008 (1.3±0.2)	.016±.006 (0.40±0.15)	.018±.004 (0.45±0.1)
		.063±.008 (1.6±0.2) (470nH-820nH)				
KQ1008	.098±.008 (2.5±0.2)	.087±.008 (2.2±0.2)	.079±.004 (2.0±0.1)	.071 <sup>+0.008</sup> <sub>-0</sub> (1.8 <sup>+0.2</sup> <sub>-0</sub> )	.018±.006 (0.45±0.15)	.018±.004 (0.45±0.1)

### ordering information

New Part #	KQ	1008	T	TE	10N	J
Type	KQ KQT	Size Code 0402 0603 0805 1008	Termination Material T: Sn	Packaging TP: 2mm pitch paper (0402: 10,000 pieces/reel) TD: 7" paper tape (0402: 2,000 pieces/reel) TE: 7" embossed plastic (0603, 0805, 1008: 2,000 pieces/reel)	Nominal Resistance 10N: 10nH R10: 0.1µH 1R0: 1.0µH	Tolerance B: ±0.1nH C: 0.2nH G: ±2% H: ±3% J: ±5% K: ±10% M: ±20%

For further information on packaging, please refer to Appendix A.

applications and ratings

Inductors

Part Designation	Marking	Nominal Inductance (nH)	L Measuring Frequency	Inductance Tolerance	Q Quality Factor Minimum	Q Measuring Frequency (MHz)	Self Resonant Frequency Minimum (MHz)	DC Resistance Maximum ( $\Omega$ )	Allowable DC Current Maximum (mA)
KQT0402T**1N0*	—	1.0	250	B: $\pm 0.1$ nH C: $\pm 0.2$ nH	16	250	11000	0.045	1360
KQT0402T**1N9*		1.9					9600	0.070	1040
KQT0402T**2N0*		2.0			8000				
KQT0402T**2N2*		2.2					7200	0.120	700
KQT0402T**2N4*		2.4			6000				
KQT0402T**2N7*		2.7					5800	0.083	760
KQT0402T**3N3*		3.3			4800				
KQT0402T**3N6*		3.6					5800	0.104	680
KQT0402T**3N9*		3.9			4400				
KQT0402T**4N3*		4.3					4200	0.150	650
KQT0402T**4N7*		4.7		4000	0.195	480			
KQT0402T**5N1*		5.1					3900	0.120	640
KQT0402T**5N6*		5.6		3680	0.180	560			
KQT0402T**6N2*		6.2					3600	0.172	500
KQT0402T**6N8*		6.8		3100	0.200	480			
KQT0402T**7N5*		7.5					2800	0.230	450
KQT0402T**8N2*		8.2		2800	0.323	400			
KQT0402T**8N7*		8.7					2720	0.214	400
KQT0402T**9N0*		9.0		2700	0.322	400			
KQT0402T**9N5*		9.5					2480	0.298	400
KQT0402T**10N*		10		2400	0.354	340			
KQT0402T**11N*		11					2400	0.393	320
KQT0402T**12N*		12		2320	0.550	320			
KQT0402T**13N*		13					2300	0.550	300
KQT0402T**15N*		15		2240	0.620	320			
KQT0402T**16N*		16					2200	0.810	300
KQT0402T**18N*		18		2100	0.830	150			
KQT0402T**19N*		19					2100	0.835	240
KQT0402T**20N*		20		2800	1.170	200			
KQT0402T**22N*		22					2000	1.120	140
KQT0402T**23N*		23		1800	1.800	140			
KQT0402T**24N*		24					1600	2.090	130
KQT0402T**27N*		27		1500	2.320	120			
KQT0402T**30N*		30							
KQT0402T**33N*		33							
KQT0402T**34N*		34							
KQT0402T**36N*		36							
KQT0402T**39N*		39							
KQT0402T**40N*		40							
KQT0402T**43N*		43							
KQT0402T**47N*	47								
KQT0402T**51N*	51								
KQT0402T**56N*	56								
KQT0402T**68N*	68								
KQT0402T**82N*	82								
KQT0402T**R10*	100								
KQT0402T**R12*	120								

NEW

\* Add tolerance character (B, C, G, H, J, K, M)

\*\* Add packaging code

For complete environmental specifications, please refer to pages 222-223.

Specifications given herein may be changed at any time without prior notice. Please confirm technical specifications before you order and/or use.

2/27/07

applications and ratings (continued)

Part Designation	Marking	Nominal Inductance (nH)	L Measuring Frequency	Inductance Tolerance	Q Quality Factor Minimum	Q Measuring Frequency (MHz)	Self Resonant Frequency Minimum (MHz)	DC Resistance Maximum (Ω)	Allowable DC Current Maximum (mA)
KQ0603TTE1N6*	C	1.6	250	J: ±5% K: ±10%	24	250	12500	0.03	700
KQ0603TTE1N8*	0	1.8			16			0.045	
KQ0603TTE3N3*	X	3.3			22		6900	0.055	
KQ0603TTE3N6*	E	3.6						0.063	
KQ0603TTE3N9*	1	3.9			20		5900	0.08	
KQ0603TTE4N3*	F	4.3						0.063	
KQ0603TTE4N7*	G	4.7			27		5800	0.116	
KQ0603TTE5N1*	Y	5.1						0.115	
KQ0603TTE6N8*	2	6.8			28		4800	0.11	
KQ0603TTE7N5*	H	7.5						0.106	
KQ0603TTE8N2*	A	8.2		31	4600		0.12		
KQ0603TTE8N7*	J	8.7					0.109		
KQ0603TTE9N5*	B	9.5		33	4800		0.125		
KQ0603TTE10N*	3	10					0.13		
KQ0603TTE11N*	K	11		35	4000		0.086		
KQ0603TTE12N*	4	12					0.13		
KQ0603TTE15N*	5	15		34	3300		0.17		
KQ0603TTE16N*	L	16					0.104		
KQ0603TTE18N*	6	18		35	3100		0.17		
KQ0603TTE22N*	7	22					0.19		
KQ0603TTE23N*	S	23	38	3000	0.15				
KQ0603TTE24N*	M	24			0.135				
KQ0603TTE27N*	8	27	40	2800	0.22				
KQ0603TTE30N*	N	30			0.144				
KQ0603TTE33N*	9	33	37	2250	0.22				
KQ0603TTE36N*	P	36			0.25				
KQ0603TTE39N*	0	39	40	2080	2000	0.28			
KQ0603TTE43N*	Q	43					0.30		
KQ0603TTE47N*	1	47	39	2200	1900	0.31			
KQ0603TTE51N*	T	51					0.34		
KQ0603TTE56N*	2	56	38	200	1700	0.49			
KQ0603TTE68N*	3	68					0.54		
KQ0603TTE72N*	4	72	34	150	1400	0.58			
KQ0603TTE82N*	5	82					0.61		
KQ0603TTER10*	6	100	32	150	1350	0.65			
KQ0603TTER11*	7	110					1.4		
KQ0603TTER12*	8	120	25	150	1300	2.2			
KQ0603TTER15*	9	150					140		
KQ0603TTER18*	0	180	24	100	1200	2.3			
KQ0603TTER20*	U	200					130		
KQ0603TTER21*	V	210	30	100	1000	2.4			
KQ0603TTER22*	1	220					120		
KQ0603TTER25*	W	250	24	100	900	2.3			
KQ0603TTER27*	2	270					170		
KQ0603TTER30*	X	300	30	50	840	3.17			
KQ0603TTER33*	3	330					110		
KQ0603TTER39*	4	390	30	50	800	3.0			
KQ0603TTER47*	5	470					100		
KQ0603TTER51*	V	510	50	50	700	3.7			
KQ0603TTER51*	V	510					80		
KQ0603TTER51*	V	510	50	50	640	1.21			
KQ0603TTER51*	V	510					190		
KQ0603TTER51*	V	510	50	50	610	1.26			
KQ0603TTER51*	V	510					170		

\* Add tolerance character (B, C, G, H, J, K, M)

For complete environmental specifications, please refer to pages 222-223.

Specifications given herein may be changed at any time without prior notice. Please confirm technical specifications before you order and/or use.

12/01/08

applications and ratings (continued)

Part Designation	Marking	Nominal Inductance (nH)	L Measuring Frequency	Inductance Tolerance	Q Quality Factor Minimum	Q Measuring Frequency (MHz)	Self Resonant Frequency Minimum (MHz)	DC Resistance Maximum ( $\Omega$ )	Allowable DC Current Maximum (mA)	
KQ0603TTER56*	6	560	50	J: $\pm 5\%$ K: $\pm 10\%$	30	50	560	2.09	130	
KQ0603TTER62*	W	620					590	1.89	150	
KQ0603TTER68*	7	680					540	1.97	140	
KQ0603TTER75*	X	750					530	2.04	130	
KQ0603TTER82*	8	820					490	3.09	110	
KQ0603TTER91*	Y	910					480	2.95	120	
KQ0603TTE1R0*	9	1000					440	5.13	90	
KQ0603TTE1R2*	0	1200					400	5.45	80	
KQ0805TTE3N3*	0	3.3	250	G: $\pm 2\%$ J: $\pm 5\%$ K: $\pm 10\%$	50	1500	6000	0.08	600	
KQ0805TTE6N8*	1	6.8				1000	5500	0.11		
KQ0805TTE8N2*	2	8.2				4700	0.12			
KQ0805TTE12N*	3	12				4000	0.15			
KQ0805TTE15N*	4	15			3400	0.17	500			
KQ0805TTE18N*	5	18			3300	0.20				
KQ0805TTE20N*	Y	20			55	2600		0.22		
KQ0805TTE22N*	6	22				2500		0.25		
KQ0805TTE27N*	7	27	60	500	2050	0.27	500			
KQ0805TTE33N*	8	33			2000	0.29				
KQ0805TTE39N*	9	39			1650	0.34				
KQ0805TTE43N*	4	43			1550	0.34				
KQ0805TTE47N*	0	47	200	65	1450	0.38	400			
KQ0805TTE56N*	1	56			1300	0.42				
KQ0805TTE68N*	2	68			1200	0.46				
KQ0805TTE82N*	3	82			1100	0.51				
KQ0805TTER10*	4	100	150	50	250	920	0.56	400		
KQ0805TTER12*	5	120				870	0.64			
KQ0805TTER15*	6	150				850	0.70			
KQ0805TTER16*	H	160				48	650		1.0	350
KQ0805TTER17*	J	170								
KQ0805TTER18*	7	180								
KQ0805TTER19*	D	190								
KQ0805TTER20*	E	200				100	50		330	600
KQ0805TTER21*	F	210								
KQ0805TTER22*	8	220								
KQ0805TTER23*	K	230								
KQ0805TTER24*	L	240	50	33	100	375	1.76	250		
KQ0805TTER25*	G	250								
KQ0805TTER27*	9	270								
KQ0805TTER33*	0	330								
KQ0805TTER39*	1	390	25	23	50	340	1.9	230		
KQ0805TTER47*	2	470								
KQ0805TTER56*	3	560								
KQ0805TTER68*	4	680								
KQ0805TTER82*	5	820	50	J: $\pm 5\%$ K: $\pm 10\%$	50	215	2.35	180		
KQ1008TTE10N*	10N	10								
KQ1008TTE12N*	12N	12								
KQ1008TTE15N*	15N	15								
KQ1008TTE18N*	18N	18	50	J: $\pm 5\%$ K: $\pm 10\%$ M: $\pm 20\%$	50	4100	0.08	1000		
KQ1008TTE12N*	12N	12				3300	0.09			
KQ1008TTE15N*	15N	15				3000	0.10			
KQ1008TTE18N*	18N	18				350	2500		0.11	

\* Add tolerance character (C, G, H, J, K, M)  
For complete environmental specifications, please refer to pages 222-223.

applications and ratings (continued)

Part Designation	Marking	Nominal Inductance (nH)	L Measuring Frequency	Inductance Tolerance	Q Quality Factor Minimum	Q Measuring Frequency (MHz)	Self Resonant Frequency Minimum (MHz)	DC Resistance Maximum ( $\Omega$ )	Allowable DC Current Maximum (mA)
KQ1008TTE22N*	22N	22	50	J: $\pm 5\%$ K: $\pm 10\%$ M: $\pm 20\%$	55	350	2400	0.12	1000
KQ1008TTE27N*	27N	27					60	1600	
KQ1008TTE33N*	33N	33			65			1500	
KQ1008TTE39N*	39N	39					60	1300	
KQ1008TTE47N*	47N	47			60			1000	
KQ1008TTE56N*	56N	56					60	950	
KQ1008TTE68N*	68N	68			60			850	
KQ1008TTE82N*	82N	82					60	750	
KQ1008TTER10*	R10	100	25	G: $\pm 2\%$ J: $\pm 5\%$ K: $\pm 10\%$	45	100		0.63	650
KQ1008TTER12*	R12	120					45	850	0.70
KQ1008TTER15*	R15	150			45			750	0.77
KQ1008TTER18*	R18	180					45	700	0.84
KQ1008TTER22*	R22	220			45			600	0.91
KQ1008TTER27*	R27	270					45	570	1.05
KQ1008TTER33*	R33	330			45			500	1.12
KQ1008TTER39*	R39	390					45	450	1.19
KQ1008TTER47*	R47	470			45			415	1.33
KQ1008TTER56*	R56	560					45	375	1.40
KQ1008TTER62*	R62	620			45			360	1.47
KQ1008TTER68*	R68	680					45	320	1.54
KQ1008TTER75*	R75	750			45			350	1.61
KQ1008TTER82*	R82	820					35	320	1.68
KQ1008TTER91*	R91	910			35			290	1.75
KQ1008TTE1R0*	1R0	1000					35	250	1.6
KQ1008TTE1R2*	1R2	1200	28	200	1.7				
KQ1008TTE1R5*	1R5	1500		28	160	1.9	270		
KQ1008TTE1R8*	1R8	1800	22		140	2.2	250		
KQ1008TTE2R2*	2R2	2200		22	110	2.7	230		
KQ1008TTE2R7*	2R7	2700	20		100	2.8			
KQ1008TTE3R3*	3R3	3300		20	90	3.1	210		
KQ1008TTE3R9*	3R9	3900	15		80	2.1	240		
KQ1008TTE4R7*	4R7	4700		15	70	2.3	200		
KQ1008TTE5R6*	5R6	5600	15		65	2.5	170		
KQ1008TTE6R8*	6R8	6800		15	60	2.9	150		
KQ1008TTE8R2*	8R2	8200							
KQ1008TTE100*	100	10000							

\* Add tolerance character (C, G, H, J, K, M)

Inductors

For complete environmental specifications, please refer to pages 222-223.

Specifications given herein may be changed at any time without prior notice. Please confirm technical specifications before you order and/or use.

11/22/08

**environmental applications**

**L-Frequency Characteristics**

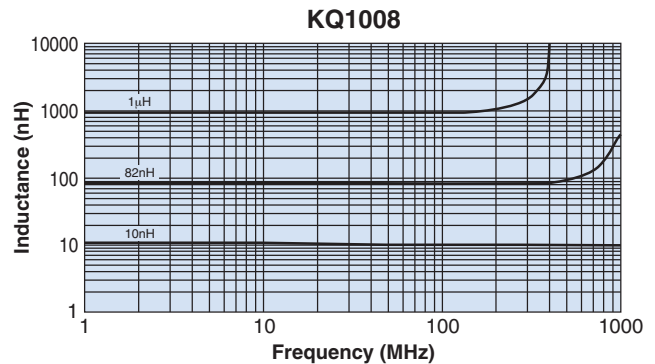
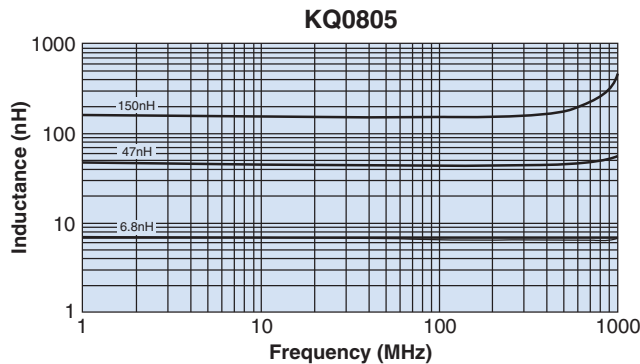
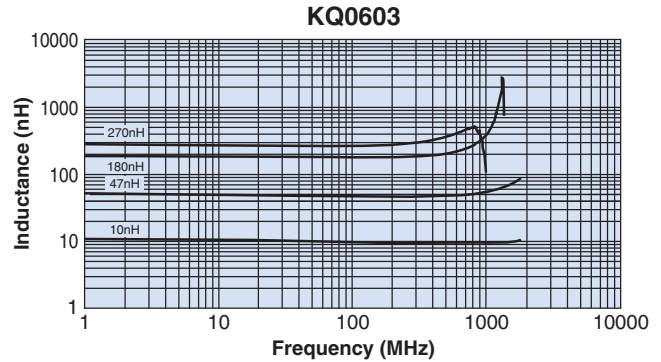
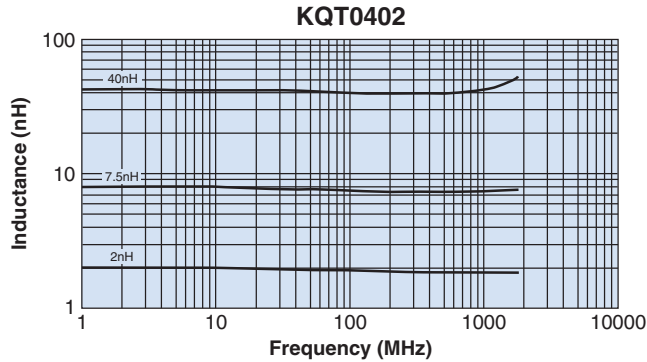

**Q-Frequency Characteristics**

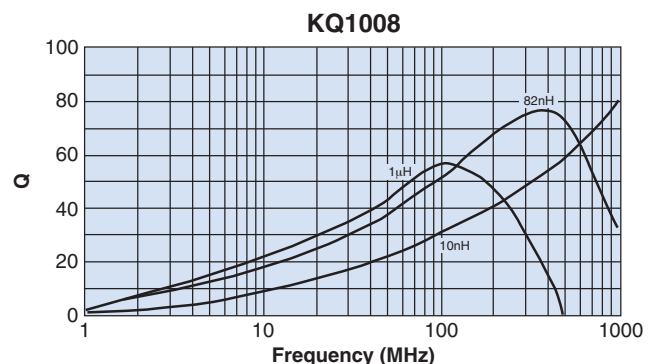
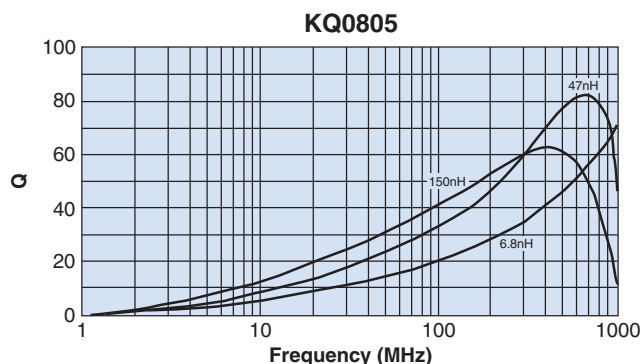
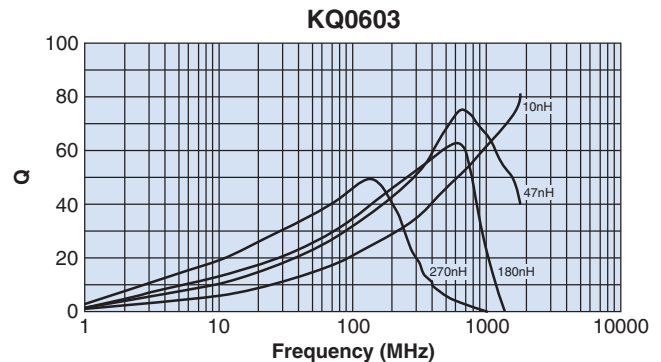
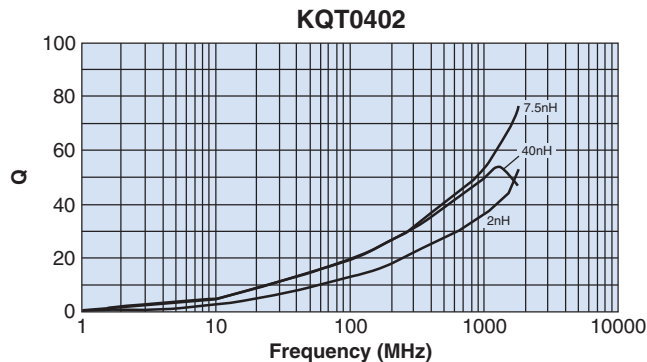

Test equipment: HP4291A impedance analyzer

Specifications given herein may be changed at any time without prior notice. Please confirm technical specifications before you order and/or use.

12/28/04

## environmental applications (continued)

### Performance Characteristics

Parameter	Requirements Maximum Limit	$\Delta$ L/L Typical	Test Method
Resistance to Soldering Heat	No significant abnormality in appearance $\Delta$ L/L: $\pm 5\%$ , $\Delta$ Q/Q: $\pm 10\%$	$\Delta$ L/L: $\pm 2.7\%$ $\Delta$ Q/Q: $\pm 6.6\%$	260°C $\pm$ 5°C, 10s $\pm$ 1s
Rapid Change of Temperature	No significant abnormality in appearance $\Delta$ L/L: $\pm 5\%$ , $\Delta$ Q/Q: $\pm 10\%$	$\Delta$ L/L: $\pm 2.1\%$ $\Delta$ Q/Q: $\pm 5.3\%$	-40°C (30min.)/ +125°C (30min.) 100 cycles
Low Temperature Exposure	No significant abnormality in appearance $\Delta$ L/L: $\pm 5\%$ , $\Delta$ Q/Q: $\pm 10\%$	$\Delta$ L/L: $\pm 1.8\%$ $\Delta$ Q/Q: $\pm 2.8\%$	-40°C $\pm$ 2°C, 1000h
High Temperature Exposure	No significant abnormality in appearance $\Delta$ L/L: $\pm 5\%$ , $\Delta$ Q/Q: $\pm 10\%$	$\Delta$ L/L: $\pm 1.8\%$ $\Delta$ Q/Q: $\pm 5.3\%$	125°C $\pm$ 2°C, 1000h
Moisture Exposure	No significant abnormality in appearance $\Delta$ L/L: $\pm 5\%$ , $\Delta$ Q/Q: $\pm 10\%$	$\Delta$ L/L: $\pm 0.9\%$ $\Delta$ Q/Q: $\pm 6.9\%$	40°C $\pm$ 2°C, 90%~95%RH, 1000h
Resistance to Solvent	No damage and marking shall remain legible	—	Accordance with MIL-STD 202F Method 215