

MICROPROCESSOR CRYSTALS AT49 (HC49 US) LOW PROFILE SURFACE MOUNT ABLS, ABL2, ABL3



RoHS Directive
2002/95/EC Compliant



FEATURES:

- High reliability, Low cost.
- Tight stability and extended temperature.
- Low profile. (2.5mm max.)
- Reflow capable.

APPLICATIONS:

- Wireless applications.
- Computers, modems, communications.
- Automotive and industrial.
- Hi-precision TCXO and clock applications.

Height Options	
PN#	H max.
ABLS	0.160 (4.2)
ABLS2	0.130 (3.3)
ABLS3	0.099 (2.5)

STANDARD SPECIFICATIONS

Frequency Range	3.579545MHz - 70.00MHz
Operation Mode	3.579545MHz ~ 24.0MHz ~ (Fundamental) 24.01MHz ~ 50.00MHz ~ (Fund. AT or BT) 24.01MHz ~ 70MHz ~ (3rd- Overtone)
Operating Temperature	0°C to +70°C (See Options)
Storage Temperature	-40°C to +85°C
Frequency Tolerance @ 25°C	±50ppm max. (See Options)
Frequency stability over temp.	±50ppm max. (See Options)*
Equivalent Series Resistance (ESR)	180 Ω max. for 3.579MHz ≤ F < 5.000MHz 120 Ω max. for 5.000MHz ≤ F < 6.000MHz 100 Ω max. for 6.000MHz ≤ F < 8.000MHz 80 Ω max. for 8.000MHz ≤ F < 9.000MHz 60 Ω max. for 9.000MHz ≤ F < 10.00MHz 50 Ω max. for 10.00MHz ≤ F < 16.00MHz 40 Ω max. for 16.00MHz ≤ F < 50.00MHz
Fundamental	
Third Overtone	100 Ω max. for 24.01MHz ≤ F < 32.00MHz 80 Ω max. for 32.00MHz ≤ F < 70.00MHz
Shunt Capacitance C ₀	7pF max.
Load Capacitance C _L	18pF (See Options)
Drive Level	1mW max., 100μW correlation
Aging @ 25°C per Year	±5ppm max.
Insulation Resistance;	500MΩ min. at 100Vdc ±15V

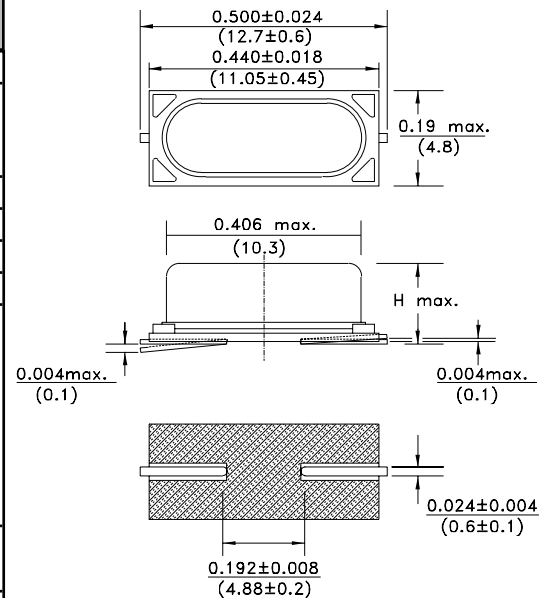

Recommended land pattern

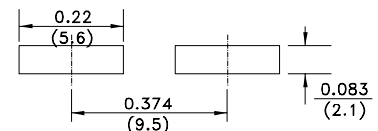

Dimensions: Inches (mm)

Please see environmental, and mechanical specifications, see appendix C. Group 1.

Tape and Reel, see appendix H.(1,000pcs./reel)

Marking, see appendix G. Reflow profile, see appendix E.

Application notes, see appendix A.

Recommended handling, see appendix F.

ORDERING OPTIONS

ABLSX - Frequency - CL - ESR - Temperature - Tolerance - Stability - Mode - Packaging

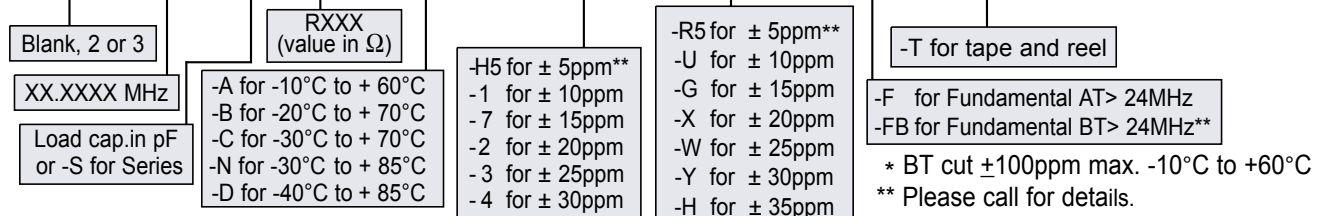

NOTE: Left blank if standard • All specifications and markings subject to change without notice

ABRACON IS
ISO 9001 / QS 9000
CERTIFIED

29 Journey • Aliso Viejo, CA 92656 • USA
(949) 448-7070 • Fax: (949) 448-8484

E-MAIL: abinfo@abracon.com • INTERNET ADDRESS: www.abracon.com

