

BOURNS®

Features

- Compact design, long life and high reliability
- Low cost compared to optical type encoders
- Available in a wide variety of configurations to meet many user requirements



PEC16 - 16 mm Incremental Encoder

Electrical Characteristics

Output	2-bit quadrature code
Closed Circuit Resistance	3 ohms maximum
Contact Rating	1 mA @ 5 VDC
Insulation Resistance	10 megohms @ 50 VDC
Dielectric Withstanding Voltage	
Sea Level	50 VAC minimum
Electrical Travel.....	Continuous
Contact Bounce (15 RPM).....	5.0 ms. maximum**
RPM (Operating).....	100 maximum**

Environmental Characteristics

Operating Temperature Range	-30 °C to +70 °C (-22 °F to +158 °F)
Storage Temperature Range	-40 °C to +85 °C (-40 °F to +185 °F)
Humidity	MIL-STD-202, Method 103B, Condition B
Vibration	30 G
Contact Bounce.....	10-55-10 Hz / 1 min. / Amplitude 1.5 mm
Shock	100 G
Rotational Life	100,000 cycles minimum
Switch Life	20,000 cycles minimum
IP Rating	IP 40

Mechanical Characteristics

Mechanical Angle	360 ° continuous
Torque	
Running	30.6 to 204 g-cm (0.42 to 2.83 oz.-in)
Mounting.....	10.2 kgf. cm (8.83 lb.-in.) maximum
Shaft Side Load (Static).....	3.06 kgf (6.7 lbs.) minimum
Weight	8 gm (0.28 oz.) maximum
Terminals	Printed circuit board terminals
Terminals	Printed circuit board terminals
Soldering Condition	
Wave Soldering.....	Sn95.5/Ag2.8/Cu0.7 solder with no-clean flux: 260 °C max. for 3-5 seconds
Hand Soldering.....	Not recommended
Hardware	One flat washer and one mounting nut supplied with each encoder.

Switch Characteristics

Switch Type	Contact Push ON Momentary SPST
Power Rating (Resistive Load)	10 mA at 5 V DC
Switch Travel	0.5 +0.4/-0.3 mm
Switch Actuation Force	360 +153/-102 gf (5 +2.1/-1.4 oz.-in.)

How To Order

PEC16 - 4 0 20 F - S 0012

Model	PEC16 - 4 0 20 F - S 0012
Terminal Configuration	4 = PC Horizontal/Rear Facing
2 = PC Pin Vertical/Down Facing	
Detent Option	0 = No Detents
1 = 12 Detents (available with 12 pulses only)	
2 = 24 Detents (available with 24 pulses only)	
Standard Shaft Length	20 = 20.0 mm
15 = 15 mm	
25 = 25.0 mm ¹	
30 = 30.0 mm ¹	
Shaft Style	F = Insulated Flatted Shaft
Switch Configuration	S = Push Momentary Switch
N = No Switch	
Resolution	0012 = 12 Pulses per 360 ° Rotation
0024 = 24 Pulses per 360 ° Rotation	

¹ Not available with switch

Quadrature Output Table

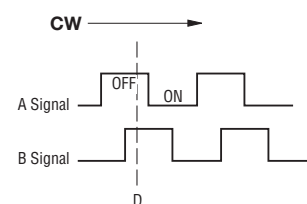

Switch Circuit

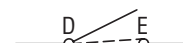

*RoHS Directive 2002/95/EC Jan 27, 2003 including Annex.

**Devices are tested using standard noise reduction filters. For optimum performance, designers should use noise reduction filters in their circuits.

Specifications are subject to change without notice.

Customers should verify actual device performance in their specific applications.

Applications

Level control, tuning and timer settings in:

- Audio-visual equipment
- Consumer electric appliances
- Radios
- Musical instrumentation
- Communications equipment

PEC16 - 16 mm Incremental Encoder BOURNS®

Product Dimensions

PEC16-2xxxF-Sxxxx

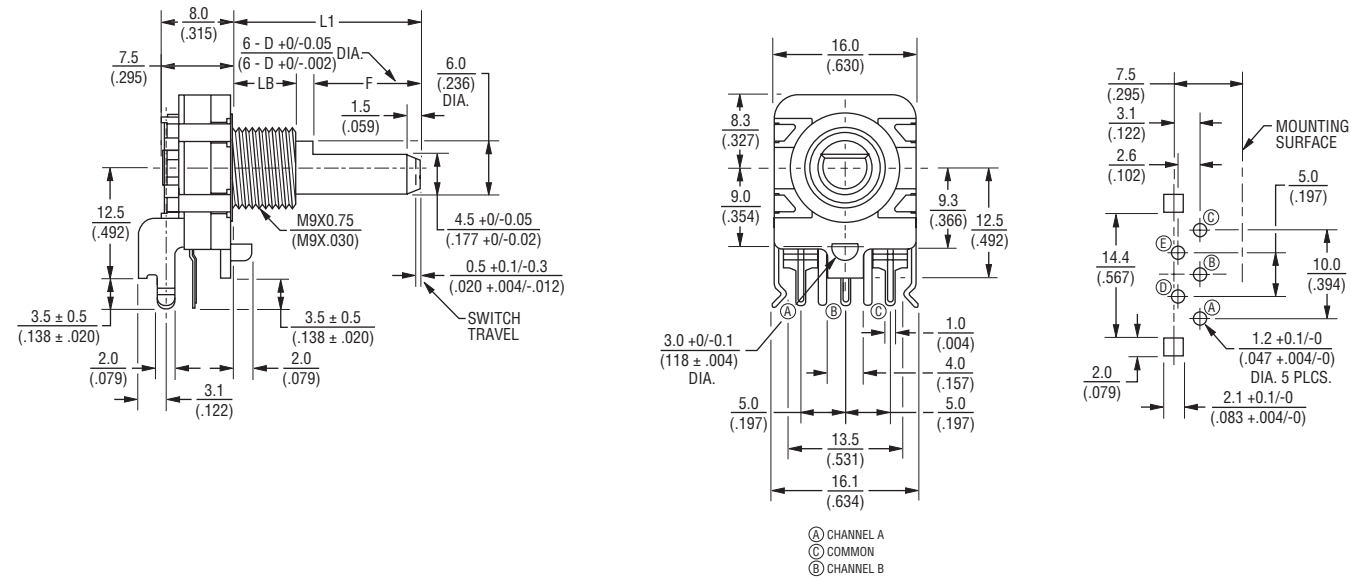

PEC16-4xxxF-Sxxxx

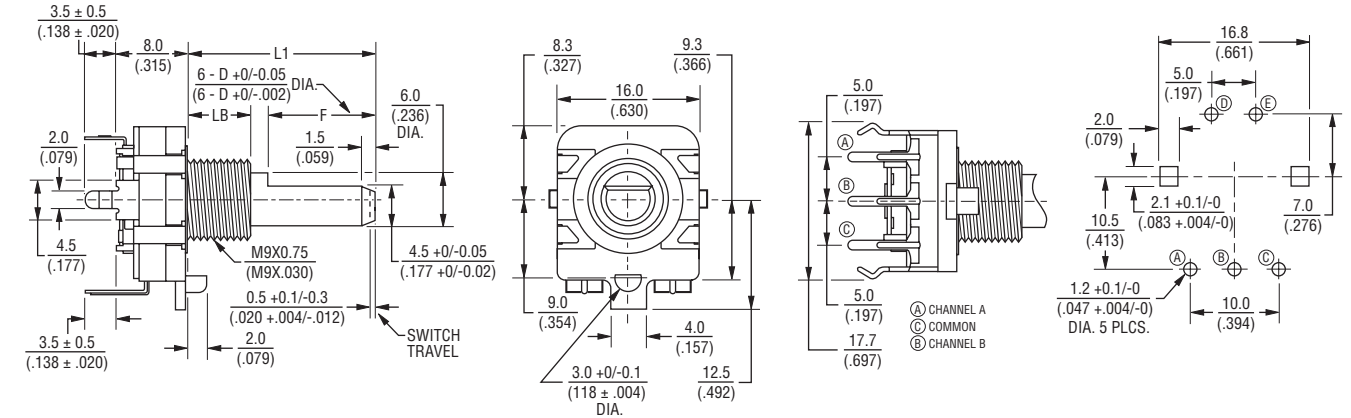

L1	15.0 (.591)	20.0 (.787)
LB	5.0 (.197)	7.0 (.276)
F	7.0 (.276)	12.0 (.472)

DIMENSIONS: $\frac{\text{MM}}{\text{(INCHES)}}$

Specifications are subject to change without notice. Customers should verify actual device performance in their specific applications.

PEC16 - 16 mm Incremental Encoder

BOURNS®

Product Dimensions

PEC16-2xxxF-Nxxxx

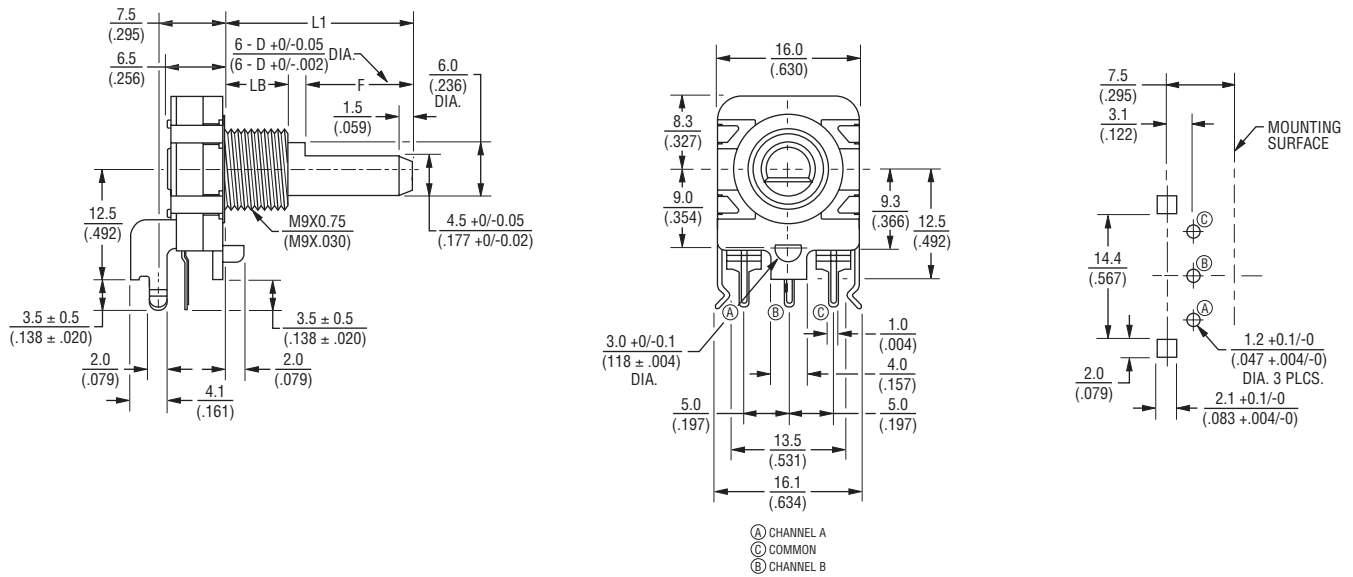

PEC16-4xxxF-Nxxxx

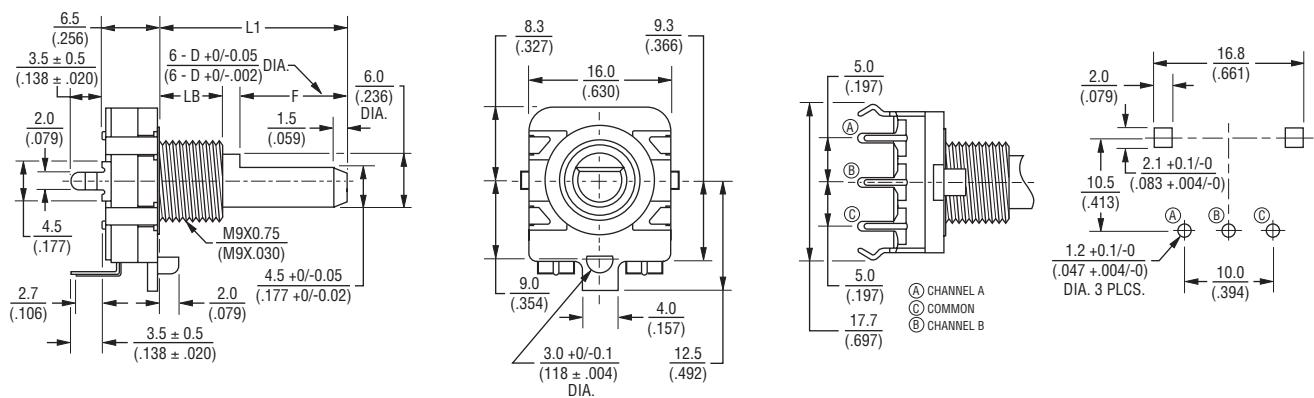

L1	15.0 (.591)	20.0 (.787)	25.0 (.984)	30.0 (1.181)
LB	5.0 (.197)	7.0 (.276)	7.0 (.276)	7.0 (.276)
F	7.0 (.276)	12.0 (.472)	12.0 (.472)	12.0 (.472)

DIMENSIONS: $\frac{\text{MM}}{\text{(INCHES)}}$

REV. 02/11

Specifications are subject to change without notice.
Customers should verify actual device performance in their specific applications.