

# 28L0138-70R-10

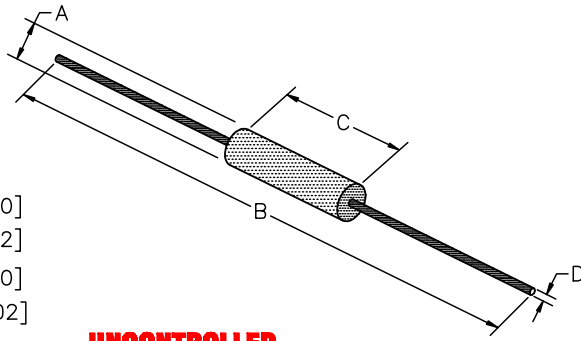

**PHYSICAL DIMENSIONS:**

A	3.51 [.138]	+ 0.25 [.010]
B	59.00 [2.32]	+ 1.57 [.062]
C	13.97 [.550]	+ 0.51 [.020]
D	0.64 [.025]	+ 0.05 [.002]

ELECTRICAL CHARACTERISTICS:				
	Z ( $\Omega$ ) @		DCR	Rated Current
	25 MHz	100MHz	( $\Omega$ )	
Nominal	123	220		
Minimum	-	165		
Maximum	-	275	0.01	5,000 mA

**UNCONTROLLED DOCUMENT**



NOTES: UNLESS OTHERWISE SPECIFIED

1. TAPED AND REELED per CURRENT EIA SPECIFICATIONS 14" REELS, 4500 PCS/REEL.
2. COMPONENTS SHOULD BE ADEQUATELY PREHEATED BEFORE SOLDERING.
3. WIRE: C10200 OXYGEN FREE COPPER (99.95 MIN.) 22AWG (.025 DIA.)
4. PLATING: 100% TIN  $5\mu \pm 2\mu$  [ $200\mu\text{in} \pm 80\mu\text{in}$ ]
5. WEIGHT/1000: .667 kgs 1.47 lbs.
6. REFERENCE STEWARD CORE P/N 28B0138-\*00.

|Z| , R, AND X vs. FREQUENCY

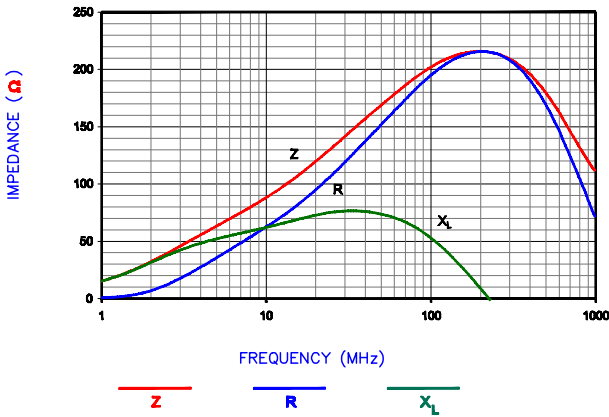

HP 4396A Network/Spectrum Analyzer  
HP 43961A Impedance Test Kit, HP 16192A Test Fixture

DIMENSIONS ARE IN mm (INCHES).				This print is the property of Laird Tech. and is loaned in confidence subject to return upon request and with the understanding that no copies shall be made without the written consent of Laird Tech. All rights to design or invention are reserved.	
H	UPDATE COMPANY LOGO	01/07/09	JRK	PROJECT/PART NUMBER: <b>28L0138-70R-10</b>	REV: <b>H</b> PART TYPE: <b>ASSEMBLY</b> DRAWN BY: <b>DTR</b>
G	ADD ROHS SYMBOL UPDATE COMPANY LOGO	04/23/07	JRK		
F	CHG P/N TO-10, REV NOTE 3, CORRECT WGT	10/16/03	JRK		
E	UPDATE PRINT FORMAT REM SHEET 40F4 ADDED NOTES TO SHEET 20F3.	10/10/01	JRK		
D	ADDED (*NOTE&DIM) TO SHT 30F4 CORRECTED DIM D ON SHT 2 OF 4	10/13/98	DTR		
C	UPDATE PRINT FORMAT	06/30/98	DTR	DATE: 06/30/98	SCALE: NTS SHEET: 2 of 3
B	MATCH REV LEVEL ON 4 OF 4	06/30/98	DTR	DATE: 06/30/98	TOOL: B0138
REV	DESCRIPTION	DATE	INT	28L0138-70R-10-2-H	

