

# 28L0138-80R-10

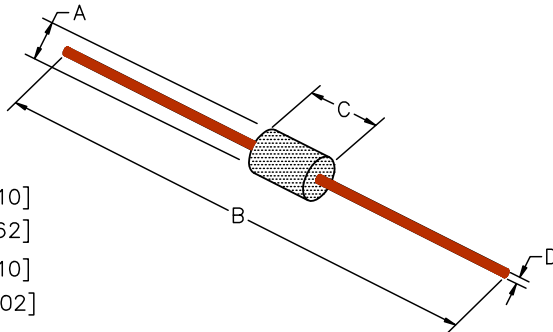

## PHYSICAL DIMENSIONS:

A	3.51 [.138]	+ 0.25 [.010]
B	59.00 [2.32]	+ 1.57 [.062]
C	5.23 [.206]	+ 0.25 [.010]
D	0.64 [.025]	+ 0.05 [.002]

ELECTRICAL CHARACTERISTICS:				
	Z ( $\Omega$ ) @		DCR ( $\Omega$ )	Rated Current
	25 MHz	100MHz		
Nominal	48	86		
Minimum	-	64		
Maximum	-	108	0.01	5,000 mA



**UNCONTROLLED DOCUMENT**

|Z|, R, AND X vs. FREQUENCY

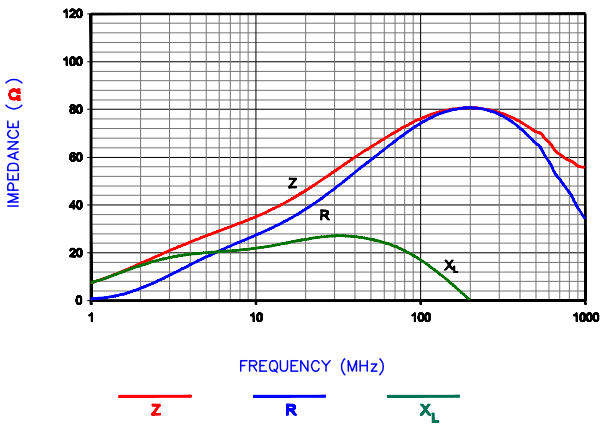

NOTES: UNLESS OTHERWISE SPECIFIED

1. TAPED AND REELED per CURRENT EIA SPECIFICATIONS 14" REELS, 4500 PCS/REEL.
2. COMPONENTS SHOULD BE ADEQUATELY PREHEATED BEFORE SOLDERING.
3. WIRE: C10200 OXYGEN FREE COPPER (99.95 MIN.) 22AWG (.025 DIA.)
4. PLATING: 100% TIN  $5\mu \pm 2\mu$  [ $200\mu\text{in} \pm 80\mu\text{in}$ ]
5. WEIGHT/1000: .25 kgs .55 lbs.
6. REFERENCE STEWARD CORE P/N 28B0138-\*00.

HP 4396A Network/Spectrum Analyzer  
HP 43961A Impedance Test Kit, HP 16192A Test Fixture

DIMENSIONS ARE IN mm (INCHES).				This print is the property of Laird Tech. and is loaned in confidence subject to return upon request and with the understanding that no copies shall be made without the written consent of Laird Tech. All rights to design or invention are reserved.	
H	UPDATE COMPANY LOGO	01/07/09	JRK	PROJECT/PART NUMBER: <b>28L0138-80R-10</b>	REV: <b>H</b> PART TYPE: <b>ASSEMBLY</b> DRAWN BY: <b>BENTON</b>
G	ADD ROHS SYMBOL UPDATE COMPANY LOGO	04/24/07	JRK		
F	CHANGE P/N TO -10, REVISE NOTE 3&4	10/16/03	JRK		
E	UPDATE PRINT FORMAT REM SHEET 40F4 ADDED NOTES TO SHEET 20F3.	10/10/01	JRK		
D	ADDED (*NOTE&DIM) TO SHT 30F4 CORRECTED DIM D ON SHT 2 OF 4	10/13/98	DTR		
C	UPDATE PRINT FORMAT	07/02/98	DTR	DATE: 06/21/90	SCALE: NTS SHEET: 2 of 3
B	UPDATE DIM C	12/18/96	GEM	DATE: 06/21/90	SCALE: NTS SHEET: 2 of 3
REV	DESCRIPTION	DATE	INT	DATE: 06/21/90	SCALE: NTS SHEET: 2 of 3

