

PC10
PC10-90
PC10-270



Now containing Maxwell Technologies patented electrode

CAPACITANCE	
Nominal capacitance	10 F
Tolerance capacitance	-10/+20%
VOLTAGE	
Rated voltage	2.5 V
Surge voltage	2.7 V
RESISTANCE	
ESR, DC Specification is as-built value. Value after test is higher. Lifespan and Cycles specifications are from as-built specification.	0.18 Ω
ESR, AC	130 mΩ
Resistance tolerance	Max.
TEMPERATURE	
Operating temperature range	-40°C to +70°C
Storage temperature range	-40°C to +85°C
POWER	
Pd	660 W/kg
Pv	1390 W/L
ENERGY	
Emax	6.9 mAh
LIFESPAN	
Lifetime ΔC < 20% decrease ESR < 100% increase	10 years (2.5V, 25°C)
Endurance ΔC < 20% decrease from rated ESR < 100% increase from rated	3,000 hours (2.5V, 70°C)
CYCLES	
Cycles	500,000
Capacitance change	ΔC < 20% decrease
Internal resistance	ESR < 100% increase
CURRENT	
Leakage current	0.04 mA
Short circuit current (Isc)	19 A
Maximum continuous current	2.5 A

SIZE	
Dimensions (L x W x H) (mm) (±0.5mm)	See drawings.
Weight	6.3g

FEATURES AND BENEFITS

- Over 500,000 duty cycles
- 10 year life capability
- Hermetically sealed, stainless steel construction
- Low profile prismatic design
- Higher energy vs. electrolytic capacitors
- Higher power vs. batteries
- UL recognized
- RoHS compliant

APPLICATIONS

- Automatic meter readers
- Automatic subsystems
- Back up power for soft shut down requirements
- Digital cameras and consumer electronics
- Wireless transmissions
- NASA space qualified

MARKINGS

Modules are marked with the following information: Rated capacitance, rated voltage, product number, name of manufacturer, positive and negative terminal, warning marking, serial number.

ADDITIONAL TECHNICAL INFORMATION

Capacitance and ESR, DC measured per document no. 1007239, available at www.maxwell.com.

I_c = leakage current after 72 hours at 25°C

$$I_{sc} = \text{short circuit current} = \frac{V_{Rated}}{ESR_{DC}}$$

R_{th} = thermal resistance

$$E_{max} = \frac{\frac{1}{2} CV^2}{3,600 \times mass}$$

$$P_{max} = \frac{V^2}{4R(1kHz) \times mass}$$

$$P_d = \frac{0.12V^2}{R(DC) \times mass}$$

PC10
PC10-90
PC10-270



DIMENSIONS (mm)

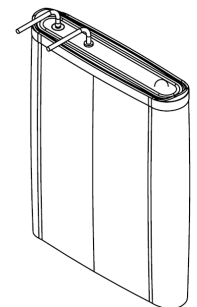
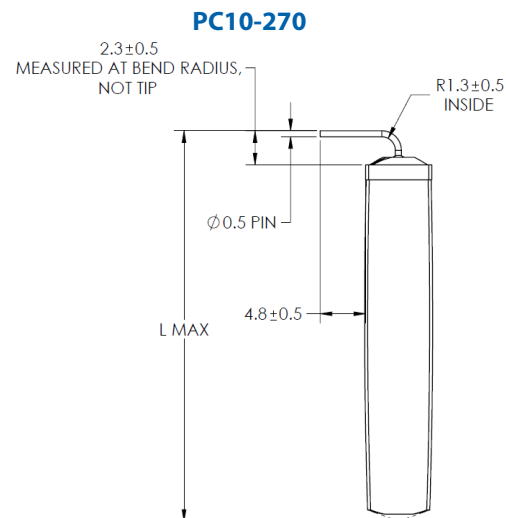
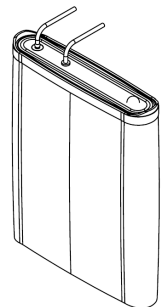
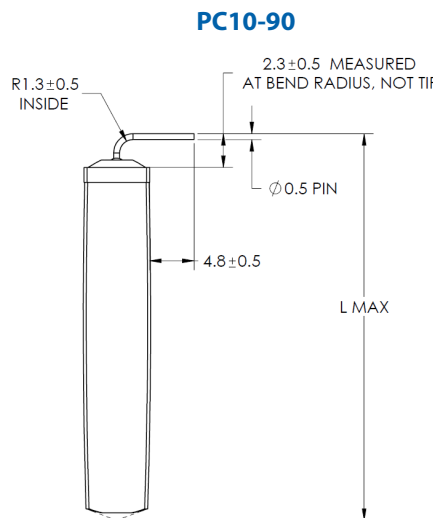
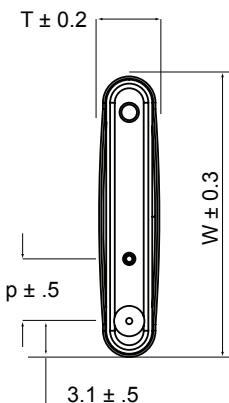
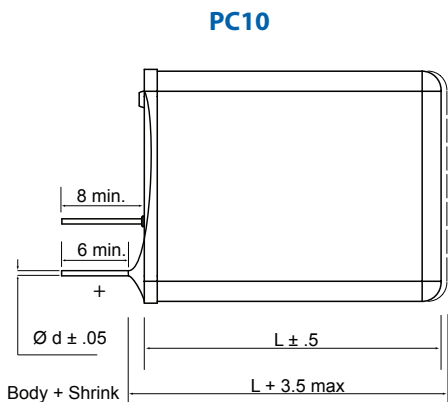

Part Description	Vol (l)	Dimensions in millimeters					Package qty.
		L	W	T	d	p	
PC10	0.003	29.6	23.6	4.8	0.5	5.1	1920
PC10-90	0.003	35.9	23.6	4.8	0.5	5.1	1824
PC10-270	0.003	35.9	23.6	4.8	0.5	5.1	1824

Product dimensions are for reference only unless otherwise identified. Product dimensions and specifications may change without notice. Please contact Maxwell Technologies directly for any technical specifications critical to application.

MOUNTING RECOMMENDATIONS

All leads are tinned from 1.5mm of capacitor body. It is recommended that parts stay within protective packaging until ready to use. Parts may be soldered or wave soldered. Request supplemental information related to mounting instructions if necessary. Components should not be operated outside recommended limits.

Maxwell Technologies, Inc.
Worldwide Headquarters
9244 Balboa Avenue
San Diego, CA 92123
USA
Tel: +1 858 503 3300
US Free Call: +1 877 511 4324
Fax: +1 858 503 3301

Maxwell Technologies SA
CH-1728 Rossens
Switzerland
Tel: +41 (0)26 411 85 00
Fax: +41 (0)26 411 85 05

Maxwell Technologies, GmbH
Brucker Strasse 21
D-82205 Gilching
Germany
T: +49 (0)8105 24 16 10
F: +49 (0)8105 24 16 19

Maxwell Technologies, Inc.
Shanghai Representative Office
Rm.2104, Suncome Liauw's Plaza
738 Shang Cheng Road, Pudong New Area
Shanghai 200120, P.R. China
Tel: +86 21 5836 5733
Fax: +86 21 5836 5620

Online: www.maxwell.com • Email: info@maxwell.com