

## Construction

Multilayer metallized paper, encapsulated and impregnated in self-extinguishing material meeting the requirements of UL 94V-0.

## Benefits

- Approvals: ENEC, UL, CSA
- Rated Voltage: 250VAC 50/60Hz
- Capacitance Range: 0.001 $\mu$ F-0.1 $\mu$ F
- Pitch: 10.2-25.4 mm
- Capacitance Tolerance:  $\pm 20\%$  for  $C > 0.1\mu\text{F}$ ,  $\pm 10\%$  for  $C \leq 0.1\mu\text{F}$
- Climatic Category: 40/100/56/B, IEC 60068-1
- Tape and reel packaging in accordance with IEC 60286-2
- RoHS compliance and lead-free terminations
- Operating temperature range of  $-40^{\circ}\text{C}$  to  $+100^{\circ}\text{C}$
- 100% screening factory test at 3000VDC
- Highest possible safety regarding active and passive flammability
- Excellent self-healing properties ensure long life even when subjected to frequent overvoltages
- Good resistance to ionization due to impregnated dielectric
- High dU/dt capability
- Impregnated paper ensures excellent stability and reliability properties, particularly in applications with continuous operation

## Applications

For worldwide use as electromagnetic interference suppressor in all Y2 applications, line-to-earth.

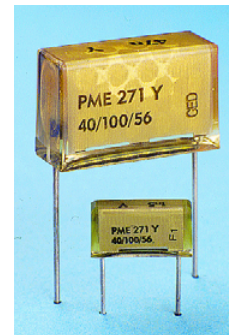

## Ordering Information

PME271	Y	(A)	410(0)	M	R30
Series	Rated Voltage	Pitch	Capacitance Code (pF)	Capacitance Tolerance	Packing Option and Leadform
Y2, Metallized Paper	Y = 250VAC	A = 10.2 B = 15.2 C = 20.3 D = 22.5 E = 25.4	Digits 2-4(3) indicates the first three digits of the capacitance value. First digit indicates the total number of digits in the capacitance value.	K = $\pm 10\%$ M = $\pm 20\%$	see Ordering Options Table

## Ordering Options Table

Standard Packaging Style	Lead Length	Ordering Code
	(mm)	
Ammo Pack		R19TA
Reel 60 mm		R19T0
Reel 500 mm		R19T1
Loose, short leads	4 <sup>+0/-1</sup>	R04
Loose, long leads	17 <sup>+0/-1</sup>	R17
Loose, long leads	30 <sup>+5</sup>	R30
Other options available on request		

## Dimension Table

Pitch	Outer Dimension		
	B	H	L
10.2	3.9	7.5	13.5
10.2	4.1	8.2	13.5
10.2	5.1	10.5	13.5
15.2	5.2	10.5	18.5
15.2	5.5	11	18.5
15.2	7.3	13	18.5
20.3	7.6	14	24
20.3	9	15	24
20.3	11.3	16.5	24
22.5	8	17	27
22.5	10	19	27
22.5	12	22	27
25.4	12.1	19	30.5
25.4	15.3	22	30.5

## Leadspacing Table

p	d	std l	max l
10.2 ± 0.4	0.6	30	30
15.2 ± 0.4	0.8	30	30
20.3 ± 0.4	0.8	30	30
22.5 ± 0.4	0.8	30	30
25.4 ± 0.4	1.0	30	30
Tolerance in Lead Length		< 30mm +0 / -1	
		30mm +5 / -0	

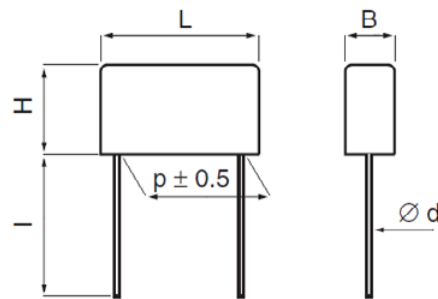

## Technical Data

Rated Voltage	250VAC 50/60Hz	
Capacitance Range	0.001 $\mu$ F-0.1 $\mu$ F	
Capacitance Tolerance	$\pm$ 20% for C > 0.1 $\mu$ F, $\pm$ 10% for C $\leq$ 0.1 $\mu$ F	
Temperature Range	-40 to +100°C	
Climatic Category	40/100/56/B	
Approvals	ENEC, UL, CSA	
Dissipation Factor	Maximum Values at +23°C	
	1 kHz	1.3%
Test Voltage Between Terminals	The 100% screening factory test is carried out at 3000 VDC. The voltage level is selected to meet the requirements in applicable equipment standards. All electrical characteristics are checked after the test. It is not permitted to repeat this test as there is a risk to damage the capacitor. KEMET is not liable in such case for any failures.	
Insulation Resistance	12,000M $\Omega$	
In DC applications	Recommended Voltage $\leq$ 1000 VDC	

## Environmental Test Data

Test	IEC Publication	Procedure
Vibration	IEC 60068–2–6 Test Fc	3 directions at 2 hours each 10 - 500 Hz at 0.75 mm or 98m/s <sup>2</sup>
Bump	IEC 60068-2-29 Test Eb	4000 bumps at 390 m/s <sup>2</sup>
Solderability	IEC 60068-2-20 Test Ta	Solder globule method
Active Flammability	IEC 60384-14	
Passive Flammability	IEC 60384-14	
Humidity	IEC 60068-2-3 Test Ca	+40°C and 90-95% R.H.



## Environmental Compliance

All KEMET EMI capacitors are RoHS compliant



RoHS Compliant

## Approvals

Mark	Specification	File Number
	EN/IEC 60384-14	SE/0140-16A
	UL 1283 (250VAC)	E100117
	CSA-C22.2 No. 8 (250VAC)	E100117

**Table 1 – Ratings & Part Number Reference**

Lead Space	Cap Value (μF)	B (mm)	H (mm)	L (mm)		dV/dt (V/μsec)	F Article Code	Part Number
10.2	0.0010	3.9	7.5	13.5		2000	P271HE102M250A	PME271Y410MR30
10.2	0.0015	3.9	7.5	13.5		2000	P271HE152M250A	PME271Y415MR30
10.2	0.0022	3.9	7.5	13.5		2000	P271HE222M250A	PME271Y422MR30
10.2	0.0033	4.1	8.2	13.5		2000	P271HH332M250A	PME271Y433MR30
10.2	0.0047	5.1	10.5	13.5		2000	P271HL472M250A	PME271Y447MR30
15.2	0.0068	5.2	10.5	18.5		1400	P271QE682M250A	PME271Y468MR30
15.2	10	5.2	10.5	18.5		1400	P271QE103M250A	PME271Y510MR30
15.2	15	5.5	11.0	18.5		1400	P271QH153M250A	PME271Y515MR30
15.2	22	7.3	13.0	18.5		1400	P271QM223M250A	PME271Y522MR30
20.3	33	7.6	14.0	24.0		1000	P271CE333M250A	PME271Y533MR30
20.3	47	9.0	15.0	24.0		1000	P271CJ473M250A	PME271Y547MR30
20.3	68	11.3	16.5	24.0		600	P271CP683M250A	PME271Y568MR30
25.4	0.10	12.1	19.0	30.5		400	P271EJ104M250A	PME271Y610MR30
Lead Space	Cap Value (μF)	B (mm)	H (mm)	L (mm)		dV/dt (V/μsec)	F Article Code	Part Number

Other part number options:

(1) Where the 14th character equal to, J (±5% tolerance), K (±10% tolerance) and M (±20% tolerance).

(2) Refer to Ordering Options Table for Ordering Code.

## Soldering Process

The implementation of RoHS Directive has forced to select SnAuCu (SAC) alloys or SnCu alloys as primary solder. This has increased the liquidus temperature from that of 183 °C for SnPb eutectic alloy to 217 – 221 °C for the new alloys. This means that the heat stress to components, even in wave soldering, has increased considerably due to higher pre-heat and wave temperatures. The Polypropylene Capacitors are especially sensitive to heat (melting point of Polypropylene is 160 – 170 °C). The wave soldering can be destructive especially for mechanically small Polypropylene Capacitors (lead spacings 5-10 mm), and great care has to be taken when soldering them. The recommended solder profiles from KEMET should be used. In case of doubt, KEMET should be consulted. In general the wave soldering curve from IEC Publication 61760- 1 edition 2 gives a good guideline for successful soldering.

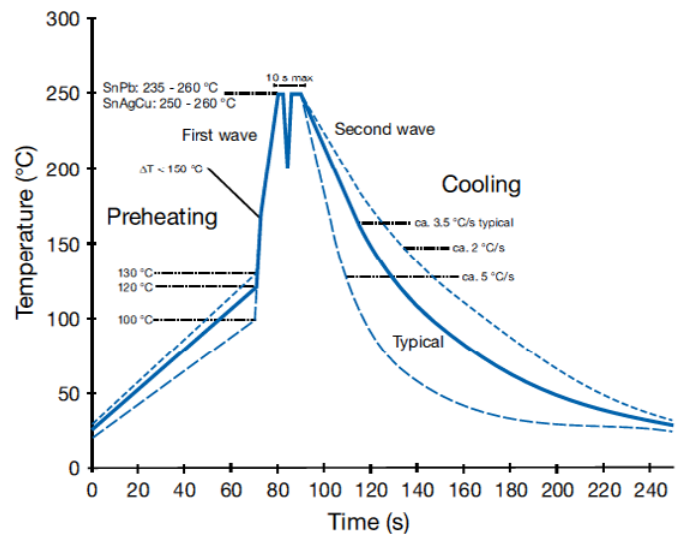

## Marking

- Manufacturer's logo
- Article series
- Rated capacitance
- Capacitance tolerance
- Rated voltage
- Capacitor class
- Approval marks
- Manufacturing date code
- IEC climatic category
- Passive flammability class
- Manufacturing date code
- Manufacturing plant

## Packaging

The taping is carried out in accordance with IEC 60286-2.

### Lead spacing 5 mm

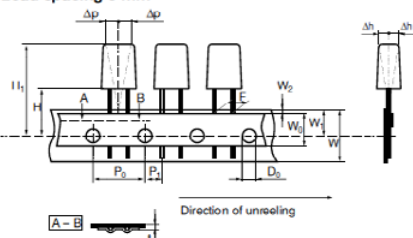

### Lead spacing 7.5 mm

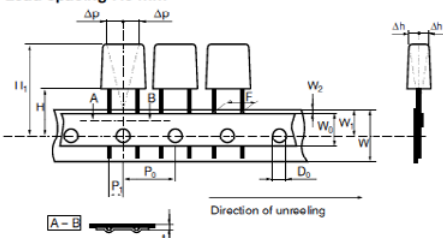

### Lead spacing 10 and 15 mm

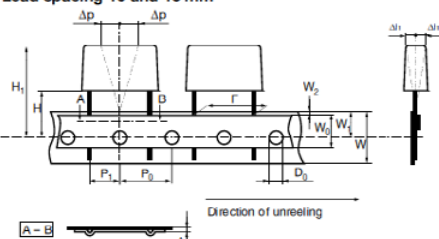

### Lead spacing 22.5 and 27.5 mm

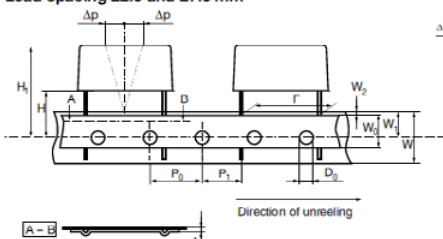

### Crimped leads

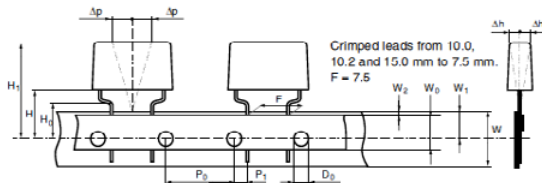

## Taping Specification

	Dimensions in mm					Standard IEC 60286-2
Lead spacing, (Tol. +0.6/-0.1)	F	5.0/7.5	7.5 Crimped Leads	10.0/15.0	22.5/27.5	F
Carrier tape width, ±0.5	W	18	18	18	18	18 (+1.0/-0.5)
Hold-down tape width, ±0.3	W <sub>0</sub>	9	12	12	12	
Position of sprocket hole, ±0.5	W <sub>1</sub>	9	9	9	9	9 (+0.75/-0.5)
Distance between tapes, max.	W <sub>2</sub>	3	3	3	3	3
Sprocket hole diameter, ±0.2	D <sub>0</sub>	4	4	4	4	4
Feed hole pitch, ±0.3	P <sub>0</sub> <sup>1)</sup>	12.7	15/12.7	12.7	12.7	12.7/15
Distance lead – feed hole, ±0.7	P <sub>1</sub>	3.85/3.75	3.75	7.7/5.2	5.3	P <sub>1</sub>
Max deviation tape – plane	Δp	1.3	1.3	1.3	1.3	1.3
Max lateral deviation	Δh	2	2	2	2	2
Total thickness, ±0.2	t	0.7	0.7	0.7	0.9 max	0.9 max
Sprocket hole/cap body	H <sup>2)</sup>	18.5 ±0.5 16.5 ±0.5		18.5 ±0.5 16.5 ±0.5	18.5 ±0.5	18.0 (+2/-0)
Sprocket hole/crimped leads	H <sub>0</sub> <sup>2)</sup>		16 ±0.5 18 ±0.5			16 ±0.5
Sprocket hole/top of cap body, max	H <sub>1</sub> <sup>3)</sup>	32/31 max	40 max	43 max	58	58 max

<sup>1)</sup> Cumulative pitch error

<sup>2)</sup> Alternatives for different insertion machines

<sup>3)</sup> Depending on case size

Note: Crimped leads available on request

## Reel Specification

Dimensions in mm			Tolerance
Reel diameter	A	360/500	max
Hub diameter	N	80	min
Arbor hole	C	30	±1
Total reel width measured at hub	W2	58	max

The standard packing for lead space ≤15 mm is 360 mm reel and for lead space >15 mm 500 mm reel.

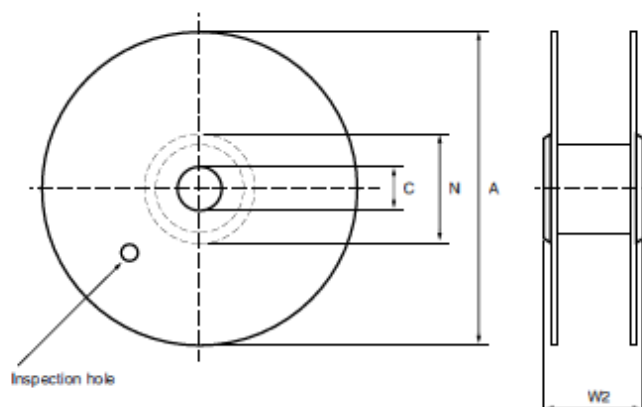

## Ammo Pack Specification

Dimensions in mm		Lead spacing, mm	
		5, 7.5, 10	15, 22.5, 27.5, 37.5
Height	H	330	(135 or 200 for CQ depending on capacitance value)
Width	W	330	(335 for CQ)
Thickness	T	50	

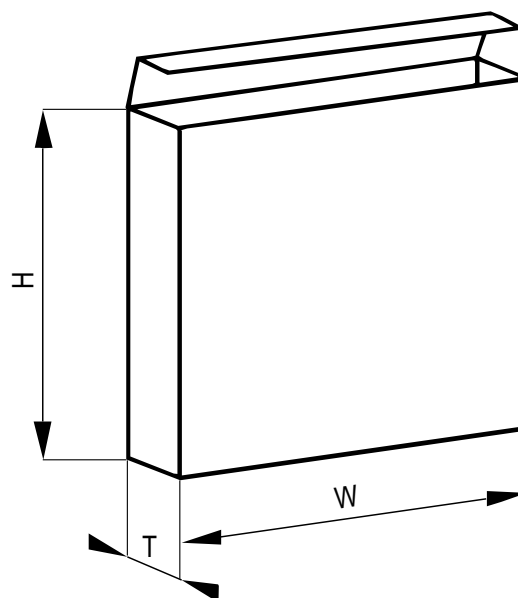

### The Manufacturing Date Code Y Z, according to IEC 60062

where Y = year, Z = month									
Year	Code	Year	Code	Year	Code	Month	Code	Month	Code
1991	B	2001	N	2011	B	Jan	1	July	7
1992	C	2002	P	2012	C	Febr	2	Aug	8
1993	D	2003	R	2013	D	March	3	Sept	9
1994	E	2004	S	2014	E	April	4	Oct	O
1995	F	2005	T	2015	F	May	5	Nov	N
1996	H	2006	U	2016	H	June	6	Dec	D
1997	J	2007	V	2017	J				
1998	K	2008	W	2018	K				
1999	L	2009	X	2019	L				
2000	M	2010	A	2020	M				



## Other KEMET Resources

Tools	
Resource	Location
Configure A Part: CapEdge	<a href="http://capacitoredge.kemet.com">http://capacitoredge.kemet.com</a>
SPICE & FIT Software	<a href="http://www.kemet.com/spice">http://www.kemet.com/spice</a>
Search Our FAQs: KnowledgeEdge	<a href="http://www.kemet.com/keask">http://www.kemet.com/keask</a>

Product Information	
Resource	Location
Products	<a href="http://www.kemet.com/products">http://www.kemet.com/products</a>
Technical Resources (Including Soldering Techniques)	<a href="http://www.kemet.com/technicalpapers">http://www.kemet.com/technicalpapers</a>
RoHS Statement	<a href="http://www.kemet.com/rohs">http://www.kemet.com/rohs</a>
Quality Documents	<a href="http://www.kemet.com/qualitydocuments">http://www.kemet.com/qualitydocuments</a>

Product Request	
Resource	Location
Sample Request	<a href="http://www.kemet.com/sample">http://www.kemet.com/sample</a>
Engineering Kit Request	<a href="http://www.kemet.com/kits">http://www.kemet.com/kits</a>

Contact	
Resource	Location
Website	<a href="http://www.kemet.com">www.kemet.com</a>
Contact Us	<a href="http://www.kemet.com/contact">http://www.kemet.com/contact</a>
Investor Relations	<a href="http://www.kemet.com/ir">http://www.kemet.com/ir</a>
Call Us	1-877-MyKEMET
Twitter	<a href="http://twitter.com/kemetcapacitors">http://twitter.com/kemetcapacitors</a>

## Disclaimer

All product specifications, statements, information and data (collectively, the "Information") are subject to change without notice.

All Information given herein is believed to be accurate and reliable, but is presented without guarantee, warranty, or responsibility of any kind, expressed or implied.

Statements of suitability for certain applications are based on our knowledge of typical operating conditions for such applications, but are not intended to constitute – and we specifically disclaim – any warranty concerning suitability for a specific customer application or use. This Information is intended for use only by customers who have the requisite experience and capability to determine the correct products for their application. Any technical advice inferred from this Information or otherwise provided by us with reference to the use of our products is given gratis, and we assume no obligation or liability for the advice given or results obtained.

Although we design and manufacture our products to the most stringent quality and safety standards, given the current state of the art, isolated component failures may still occur. Accordingly, customer applications which require a high degree of reliability or safety should employ suitable designs or other safeguards (such as installation of protective circuitry or redundancies) in order to ensure that the failure of an electrical component does not result in a risk of personal injury or property damage.

Although all product-related warnings, cautions and notes must be observed, the customer should not assume that all safety measures are indicated or that other measures may not be required.

## KEMET Corporation World Headquarters

2835 KEMET Way  
Simpsonville, SC 29681

Mailing Address:  
P.O. Box 5928  
Greenville, SC 29606

www.kemet.com  
Tel: 864-963-6300  
Fax: 864-963-6521

### Corporate Offices

Fort Lauderdale, FL  
Tel: 954-766-2800

## North America

### Southeast

Lake Mary, FL  
Tel: 407-855-8886

### Northeast

Wilmington, MA  
Tel: 978-658-1663

West Chester, PA  
Tel: 610-692-4642

### Central

Schaumburg, IL  
Tel: 847-882-3590

Carmel, IN  
Tel: 317-706-6742

### West

Milpitas, CA  
Tel: 408-433-9950

### Mexico

Zapopan, Jalisco  
Tel: 52-33-3123-2141

## Europe

### Southern Europe

Geneva, Switzerland  
Tel: 41-22-715-0100

Paris, France  
Tel: 33-1-4646-1009

Sasso Marconi, Italy  
Tel: 39-051-939111

Milan, Italy  
Tel: 39-02-57518176

Rome, Italy  
Tel: 39-06-23231718

Madrid, Spain  
Tel: 34-91-804-4303

### Central Europe

Landsberg, Germany  
Tel: 49-8191-3350800

Dortmund, Germany  
Tel: 49-2307-3619672

Kwidzyn, Poland  
Tel: 48-55-279-7025

### Northern Europe

Bishop's Stortford, United Kingdom  
Tel: 44-1279-757201

Weymouth, United Kingdom  
Tel: 44-1305-830747

Coatbridge, Scotland  
Tel: 44-1236-434455

Färjestaden, Sweden  
Tel: 46-485-563934

Espoo, Finland  
Tel: 358-9-5406-5000

## Asia

### Northeast Asia

Hong Kong  
Tel: 852-2305-1168

Shenzhen, China  
Tel: 86-755-2518-1306

Beijing, China  
Tel: 86-10-5829-1711

Shanghai, China  
Tel: 86-21-6447-0707

Taipei, Taiwan  
Tel: 886-2-27528585

### Southeast Asia

Singapore  
Tel: 65-6586-1900

Penang, Malaysia  
Tel: 60-4-6430200

Bangalore, India  
Tel: 91-806-53-76817

*Note: KEMET reserves the right to modify minor details of internal and external construction at any time in the interest of product improvement. KEMET does not assume any responsibility for infringement that might result from the use of KEMET Capacitors in potential circuit designs. KEMET is a registered trademark of KEMET Electronics Corporation.*