

# PHE840MA5100MA01R17

aka F840AG103M275A

Capacitor, film, 0.01  $\mu$ F, +/-20% Tol, -55/+105C, Safety: X2, 275VAC,  
Lead Spacing=10 mm

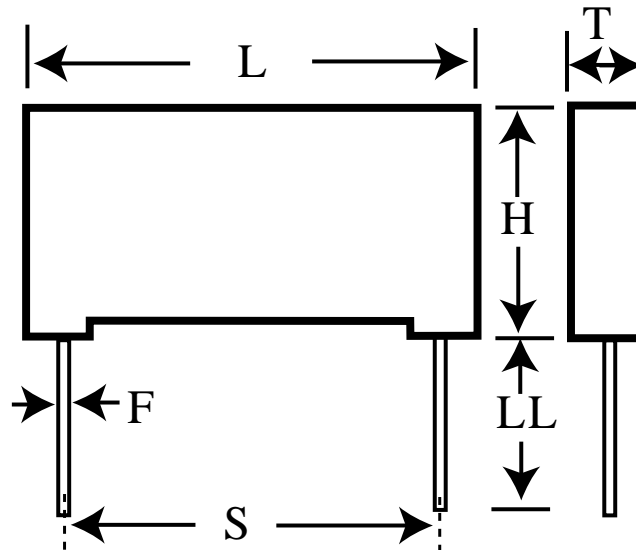

## Dimensions (mm)

ID	Dimension	Tolerance
L	13	max
H	9	max
T	4	max
S	10	+/-0.4
LL	17	nom
F	0.6	nom

## Specifications

Manufacturer:	KEMET
Brand:	Rifa
Capacitance:	0.01 $\mu$ F
Temperature Range:	-55/+105C
Rated Temperature:	105C
Voltage @ rated temp:	760V
Voltage AC:	275VAC
Tolerance:	+/-20%
Body Type:	Radial Box
Construction:	Non-inductive
Application:	Safety: X2
Dielectric:	Metallized Polypropylene
Insulation Resistance:	30 GOhm
Maximum dVdT:	100v/us
UL_1414:	250V
UL_1283:	280V
IEC_60384-14:	275V
EN_132400:	275V
C_22.2_NO.1:	250V
C_22.2_NO.8:	280V
Miscellaneous Electrical:	PHE840M
Package Kind:	Bulk
Package Quantity:	1000