

Transformers Pulse, Trigger Type

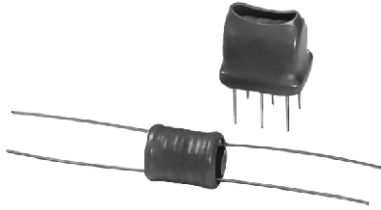

FEATURES

- Choice of printed circuit or bobbin-type configurations.
- Designed to transfer high amplitude or long duration pulses without saturation.
- Designed for low-cost trigger source isolation in half and full wave SCR power control circuits, including motor speed controls, heater controls and incandescent lighting controls.



RoHS
COMPLIANT

STANDARD ELECTRICAL SPECIFICATIONS							
DASH NUMBER	TURNS RATIO	FIGURE	PRIMARY INDUCTANCE MINIMUM (μH)	LEAKAGE INDUCTANCE MAXIMUM (μH)	INTERWINDING CAPACITY MAXIMUM (pF)	DCR MAXIMUM (Ohms)	UNIPOLAR ET (V-μSEC)
101*	1:1 ± 10 %	1/3	200	3	800	1.5-1.5	570
102*	1:1 ± 10 %	1/3	500	6	1500	4.5-4.5	912
103*	1:1 ± 10 %	1/3	1000	12	2000	8-8	1283
104	1:1 ± 10 %	1/3	2000	13	2800	12-12	1853
105	1:1 ± 10 %	1/3	5000	15	3500	18-18	2850
106*	1:1:1 ± 10 %	2/4	200	3	800	2-2-2	570
107	1:1:1 ± 10 %	2/4	500	6	1500	6-6-6	912
108	1:1:1 ± 10 %	2/4	1000	12	2000	10-10-10	1283
109	1:1:1 ± 10 %	2/4	2000*	13	2800	15-15-15	1853
110	1:1:1 ± 10 %	2/4	5000	15	3500	27-27-27	2850
111*	2:1 ± 10 %	1/3	500	6	1000	4-2	912
112*	2:1 ± 10 %	1/3	1000	10	1300	10-2	1288
113	2:1 ± 10 %	1/3	2000	12	1800	10-5	1881
114	2:1 ± 10 %	1/3	5000	15	2400	18-10	2850
115*	2:1:1 ± 10 %	2/4	200	8	700	4-2-2	570
116*	2:1:1 ± 10 %	2/4	500	11	1000	6-2-2	912
117*	2:1:1 ± 10 %	2/4	1000	15	1300	5-2-2	1311
118	2:1:1 ± 10 %	2/4	2000	60	2000	10-5-5	1881
119	2:1:1 ± 10 %	2/4	5000	75	2100	20-10-10	2850
120*	5:1 ± 10 %	1/3	5000	1500	400	19-3	2850
121	5:1:1 ± 10 %	2/4	5000	1500	400	20-4-4	2850

*Standard items in PT-10 Model. Other Dash Numbers available on request. All Dash Numbers standard in PT-20 Model.

ELECTRICAL SPECIFICATIONS

Primary Inductance Values: From 200 μH to 5000 μH

Turns Ratio: 1:1, 1:1:1, 2:1, 2:1:1 and 5:1

Temperature Range: - 10 °C to + 70 °C

Dielectric Test at 60 Hz: 1600 V RMS (Windings to case)

AC Line Voltage at 60 Hz: 240 V RMS maximum in test circuits shown

MATERIAL SPECIFICATIONS

Bobbin: Nylon

Leads: Tinned, solderable

PT-10 = Polyurethane insulated magnet wire for clip or bracket mounting

PT-20 = Tinned copper 0.025 [0.635]Sq. for printed circuit mounting

Header: Thermoset plastic

Covering: Thermoplastic

CIRCUIT DIAGRAMS

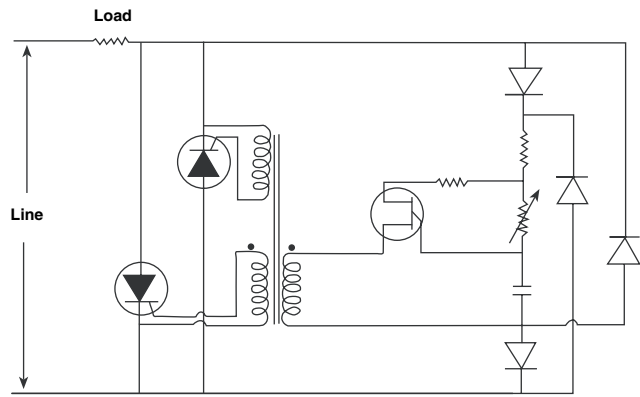

Transformer Coupled Unijunction Transistor Triggering Circuit

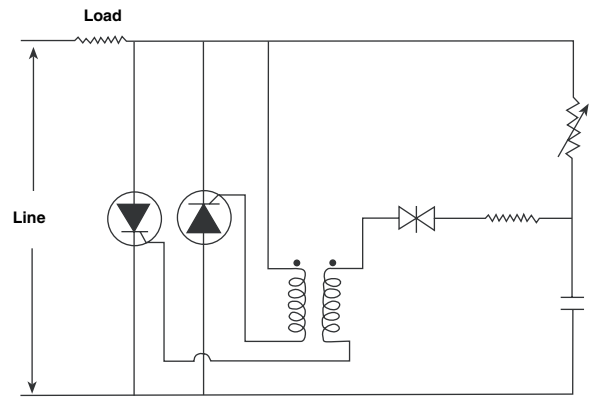

Transformer Coupled Breakdown Diode Triggering Circuit

DIMENSIONS in inches (millimeters)

PT-10

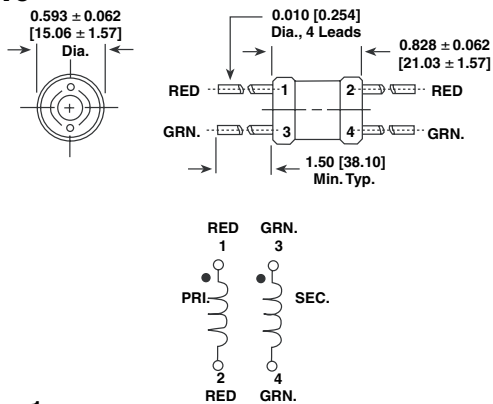

Figure 1

PT-10

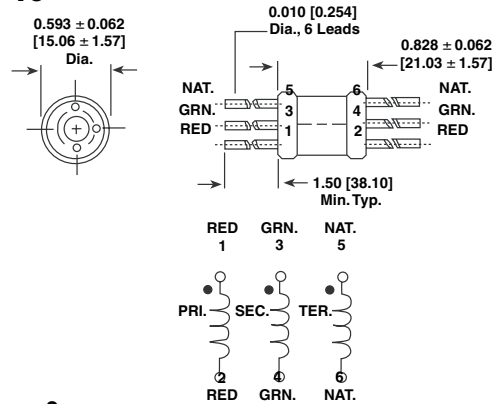

Figure 2

PT-20

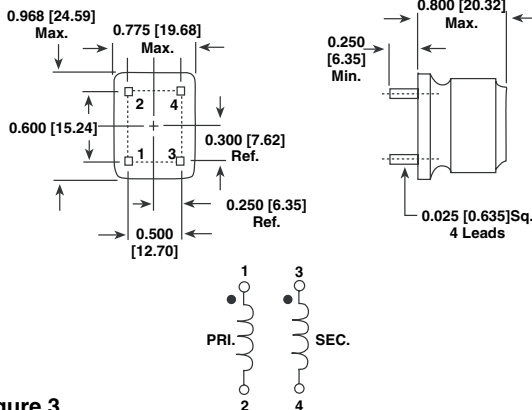

Figure 3

PT-20

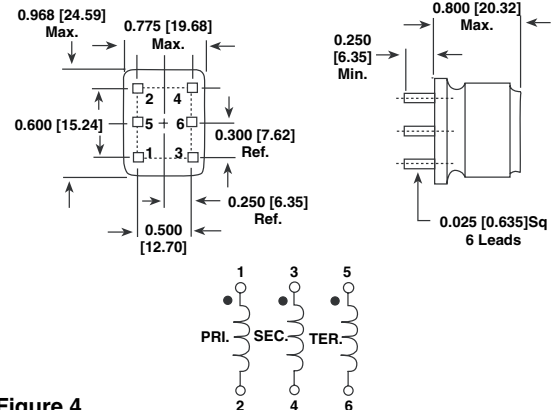

Figure 4

PART MARKING

- Vishay Dale
- Model
- Style
- Dash number



ORDERING INFORMATION

PT
MODEL

10
STYLE

101
DASH NUMBER

EB
PACKAGE CODE

e2
JEDEC LEAD (Pb)-FREE
STANDARD

GLOBAL PART NUMBER

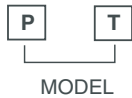



Disclaimer

ALL PRODUCT, PRODUCT SPECIFICATIONS AND DATA ARE SUBJECT TO CHANGE WITHOUT NOTICE TO IMPROVE RELIABILITY, FUNCTION OR DESIGN OR OTHERWISE.

Vishay Intertechnology, Inc., its affiliates, agents, and employees, and all persons acting on its or their behalf (collectively, "Vishay"), disclaim any and all liability for any errors, inaccuracies or incompleteness contained in any datasheet or in any other disclosure relating to any product.

Vishay makes no warranty, representation or guarantee regarding the suitability of the products for any particular purpose or the continuing production of any product. To the maximum extent permitted by applicable law, Vishay disclaims (i) any and all liability arising out of the application or use of any product, (ii) any and all liability, including without limitation special, consequential or incidental damages, and (iii) any and all implied warranties, including warranties of fitness for particular purpose, non-infringement and merchantability.

Statements regarding the suitability of products for certain types of applications are based on Vishay's knowledge of typical requirements that are often placed on Vishay products in generic applications. Such statements are not binding statements about the suitability of products for a particular application. It is the customer's responsibility to validate that a particular product with the properties described in the product specification is suitable for use in a particular application. Parameters provided in datasheets and/or specifications may vary in different applications and performance may vary over time. All operating parameters, including typical parameters, must be validated for each customer application by the customer's technical experts. Product specifications do not expand or otherwise modify Vishay's terms and conditions of purchase, including but not limited to the warranty expressed therein.

Except as expressly indicated in writing, Vishay products are not designed for use in medical, life-saving, or life-sustaining applications or for any other application in which the failure of the Vishay product could result in personal injury or death. Customers using or selling Vishay products not expressly indicated for use in such applications do so at their own risk and agree to fully indemnify and hold Vishay and its distributors harmless from and against any and all claims, liabilities, expenses and damages arising or resulting in connection with such use or sale, including attorneys fees, even if such claim alleges that Vishay or its distributor was negligent regarding the design or manufacture of the part. Please contact authorized Vishay personnel to obtain written terms and conditions regarding products designed for such applications.

No license, express or implied, by estoppel or otherwise, to any intellectual property rights is granted by this document or by any conduct of Vishay. Product names and markings noted herein may be trademarks of their respective owners.