

Buccaneer® Antenna

SMB ANTENNA

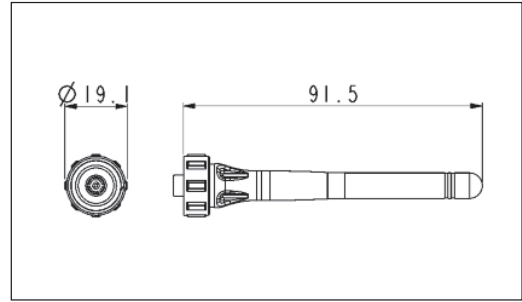

- Dust & waterproof to IP68 EN60529 when mated
- Secure screw thread locking
- Built-in sealed antenna
- Mates with SMB Buccaneer PX0414



BUCCANEER

Part no.	Description
PX0407	IP68 rated, Buccaneer Antenna, 2.4 to 2.5GHz frequency band
PX0408	IP68 rated, Buccaneer Antenna, 440 to 470MHz frequency band
PX0409	IP68 rated, Buccaneer Antenna, 850-900/1800/1900MHz frequency band

SPECIFICATION

<b>Electrical:</b>	
Frequency	2.4 to 2.5GHz
PX0407	440 to 470MHz
PX0408	850-900/1800/1900MHz
PX0409	Half Wavelength
Configuration	Omnidirectional
Radiation	Vertical
Polarization	50Ω nominal
Impedance	<2
VSWR	
<b>Mechanical:</b>	
Sealing	IP68, EN60529, when mated
Operating Temperature:	-20°C to +65°C
<b>Material:</b>	
Body Mouldings	PVC
Flammability Rating	UL94V-0
UV Resistance	EN50021:1999
<b>RoHS</b>	Compliant

The Buccaneer Antenna series are robust and completely waterproof antennas specifically developed for the 2.4GHz, 440-470MHz and 850-900/1800/1900MHz frequency bands.

Integrating the antenna with its waterproof connector can reduce the total number of connectors in the RF chain, reducing insertion losses, effectively increasing the total system gain.

Typical application areas are industrial, scientific and medical (ISM) radio for instrumentation and telemetry systems, including Zigbee. Additional applications are base stations and outdoor hotspot installations, specifically for wireless LAN, GSM and Bluetooth communication equipment.

Designed to the same style as Bulgin's 400 Series Buccaneer, the sealed antenna with its integrated SMB connector has an overall diameter of just 19mm with a panel fixing hole of 16mm diameter. Rated at IP68, it provides complete protection from harsh environments, and all electrical connections are gold plated to ensure system performance and reliability is maintained.

The panel connector, PX0414, with an SMB jack, is supplied with RG-174 cable already terminated in lengths of 0.5m, 1.0m and 1.5m, this provides fast assembly to the panel and only requires termination into the equipment.

Having a two-part solution of the removable antenna and panel connector makes installation and testing a much simpler process, whilst also ensuring that the environmental seal and enclosure integrity are maintained.