



Features

- Surface Mount Device
- Reduced footprint size
- High voltage surge capabilities
- Assists in meeting ITU K.20/K.21/K.45 specifications
- RoHS compliant*
- Agency recognition: 

Applications

- Provides overcurrent protection in:
- Customer Premise Equipment (CPE)
 - Central Office (CO)
 - Access/Outside Plant Equipment

MF-SM013/250V - Telecom PTC Resettable Fuses

Electrical Characteristics

Model	Max. Operating Voltage Volts	Max. Interrupt Ratings		Hold Current Amps at 23 °C	Initial Resistance		One Hour Post-Trip Resistance Ohms at 23 °C	Tripped Power Dissipation Watts at 23 °C
		Volts (V)	Amps (A)		Ohms at 23 °C	Ohms at 23 °C		
		Max.	Max.		I _H	Min.		
MF-SM013/250V	60	250	3.0	0.13	6.5	12.0	20.0	3.0

Environmental Characteristics

Operating Temperature	-40 °C to +85 °C
Maximum Device Surface Temperature in Tripped State.....	125 °C
Passive Aging	+85 °C, 1000 hours.....±5 % typical resistance change +60 °C, 1000 hours.....±5 % typical resistance change
Humidity Aging	+85 °C, 85 % R.H. 500 hours.....±5 % typical resistance change
Thermal Shock	MIL-STD-202F, Method 107G,±10 % typical resistance change +125 °C to -55 °C, 10 times.....±15 % typical resistance change
Solvent Resistance	MIL-STD-202, Method 215B.....No change
Lead Solderability	ANSI/J-STD-002
Flammability	IEC 695-2-2.....No Flame for 60 secs.
Vibration	MIL-STD-883C, Method 2007.1, Condition A.....No change

Test Procedures And Requirements For Model SM013/250V Series

Test	Test Conditions	Accept/Reject Criteria
Visual/Mech.	Verify dimensions and materials.....	Per MF physical description
Resistance	In still air @ 23 °C	R _{min} ≤ R ≤ R _{max}
Time to Trip	At specified current, V _{max} , 23 °C	T ≤ max. time to trip (seconds)
Hold Current	30 min. at I _{hold}	No trip
Trip Cycle Life	V _{max} , I _{max} , 100 cycles	No arcing or burning
Trip Endurance	V _{max} , 48 hours.....	No arcing or burning
Solderability	MIL-STD-202F, Method 208F	95 % min. coverage
UL File Number.....	E 174545S	
CSA File Number	CA 110338	
TÜV File Number	R2057213	

Thermal Derating Chart -I_{hold} / I_{trip} (Amps)

Model	Ambient Operating Temperature									
	-40 °C	-20 °C	0 °C	23 °C	40 °C	50 °C	60 °C	70 °C	85 °C	
MF-SM013/250V	0.21 / 0.42	0.18 / 0.37	0.16 / 0.31	0.13 / 0.26	0.10 / 0.23	0.09 / 0.18	0.08 / 0.15	0.07 / 0.12	0.05 / 0.10	

*RoHS Directive 2002/95/EC Jan 27 2003 including Annex
 Specifications are subject to change without notice.
 Customers should verify actual device performance in their specific applications.

MF-SM013/250V Series - Telecom PTC Resettable Fuses **BOURNS®**

Product Dimensions

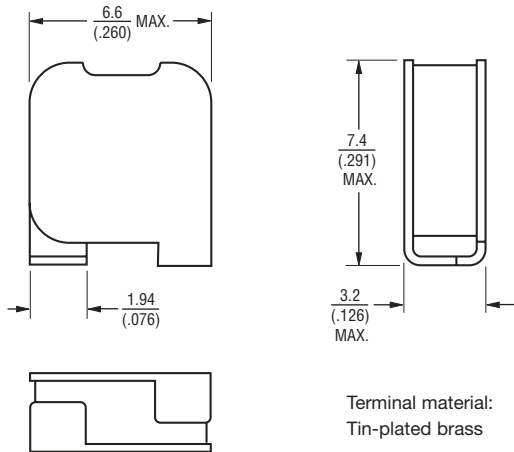

Recommended Pad Layout

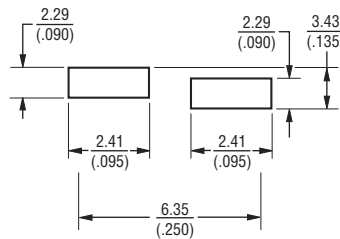

DIMENSIONS = $\frac{\text{MM}}{\text{(INCHES)}}$

Packaging:
TAPE & REEL: 1000 pcs. per reel

Solder Reflow Recommendations

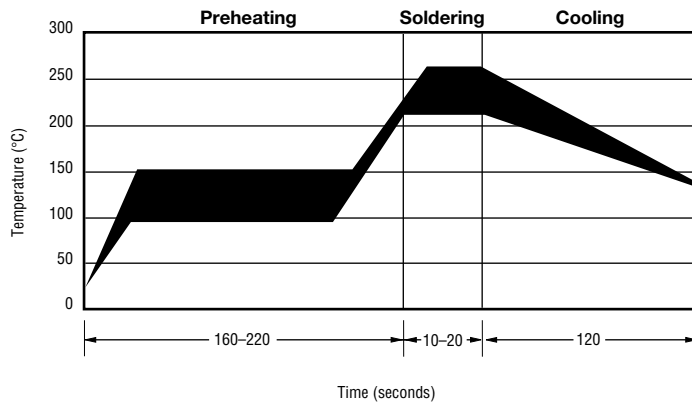

Solder reflow

- Recommended reflow methods: IR, vapor phase oven, hot air oven.
- Devices are not designed to be wave soldered to the bottom side of the board.
- Gluing the devices is not recommended.
- Recommended maximum paste thickness is 0.25 mm (.010 inch).
- Devices can be cleaned using standard industry methods and solvents.

Note:

- If reflow temperatures exceed the recommended profile, devices may not meet the performance requirements.

Rework

- A device should not be reworked.

Storage Recommendations

The recommended long term storage conditions for Multifuse® Polymer PTC devices are 40 °C maximum and 70 % RH maximum. All devices should remain in the original sealed packaging prior to use. Devices may not conform with data sheet specifications if these storage recommendations are exceeded. Devices stored in this manner have an indefinite shelf life.

Specifications are subject to change without notice.
Customers should verify actual device performance in their specific applications.

MF-SM013/250V Series - Telecom PTC Resettable Fuses **BOURNS®**

Typical Time to Trip at 23 °C

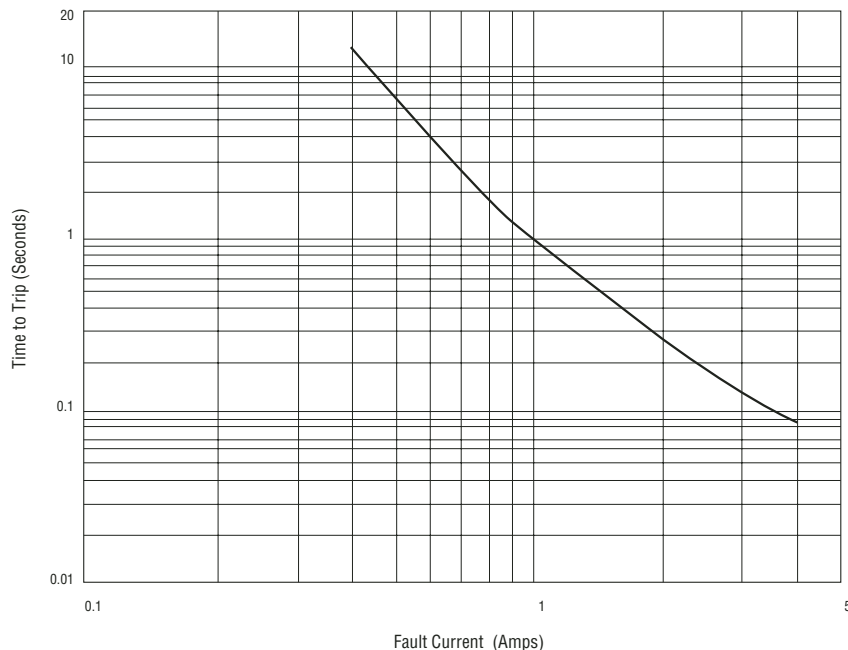

Typical Part Marking

Represents total content. Layout may vary.

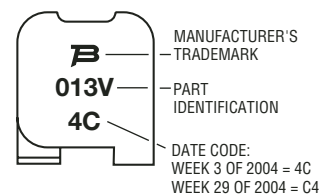

How to Order

MF - SM 013/250V - 2

- Multifuse® Product Designator
 - Series SM = Surface Mount Component
 - Hold Current, I_{hold} 013 = 0.13 Amps
 - Max. Interrupt Voltage, V 250 = 250 Volts
 - Telecom Options V = Vertical Profile (Surface Mount Products Only)
 - Packaging Options
 - 0 = Bulk Packaging
 - 2 = Tape and Reel*
- *Packaged per EIA486-B

Specifications are subject to change without notice.
Customers should verify actual device performance in their specific applications.

MF-SM013/250V, REV. D, 01/08

**MF-SM013/250V
per EIA 481-1**

Tape Dimensions

W	$\frac{16.0 \pm 0.3}{(0.630 \pm 0.012)}$
P ₀	$\frac{4.0 \pm 0.1}{(0.157 \pm 0.004)}$
P ₁	$\frac{8.0 \pm 0.1}{(0.315 \pm 0.004)}$
P ₂	$\frac{2.0 \pm 0.1}{(0.079 \pm 0.004)}$
A ₀	$\frac{3.3 \pm 0.1}{(0.130 \pm 0.004)}$
B ₀	$\frac{6.66 \pm 0.1}{(0.262 \pm 0.004)}$
B ₁ max.	$\frac{7.2}{(0.283)}$
D ₀	$\frac{1.5 \pm 0.1}{(0.059 \pm 0.004)}$
F	$\frac{7.5 \pm 0.1}{(0.295 \pm 0.004)}$
E ₁	$\frac{1.75 \pm 0.1}{(0.069 \pm 0.004)}$
E ₂ min.	$\frac{14.25}{(0.561)}$
T max.	$\frac{0.45}{(0.018)}$
T ₁ max.	$\frac{0.1}{(0.004)}$
K ₀	$\frac{7.0}{(0.276)}$
Leader min.	$\frac{390}{(15.35)}$
Trailer min.	$\frac{160}{(6.30)}$
Reel Dimensions	
A max.	$\frac{340}{(13.39)}$
N min.	$\frac{50}{(1.97)}$
W ₁	$\frac{16.4}{(0.646)}$
W ₂ max.	$\frac{22.4}{(0.882)}$

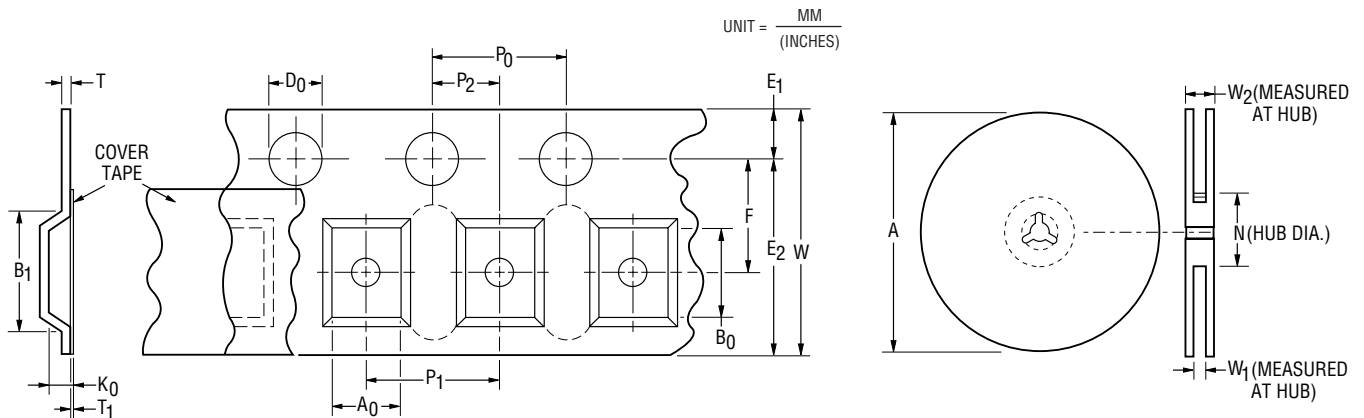

Specifications are subject to change without notice.
Customers should verify actual device performance in their specific applications.