



特長

- 薄型 SIP パッケージ
- UL E142422
- 高耐圧・高 I_{FSM}
- 大電流容量
- 高放熱伝導性

Feature

- Thin-SIP
- UL E142422
- High Voltage・Large I_{FSM}
- Large Io
- High Thermal Radiation

■ 外観図 OUTLINE

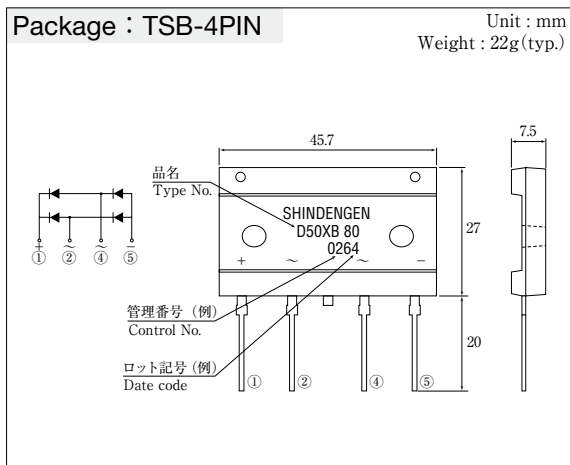

外形図については新電元 Web サイト又は〈半導体製品一覧表〉をご参照下さい。捺印表示については捺印仕様をご確認下さい。
For details of outline dimensions, refer to our web site or the Semiconductor Short Form Catalog. As for the marking, refer to the specification "Marking, Terminal Connection."

■ 定格表 RATINGS

● 絶対最大定格 Absolute Maximum Ratings (指定のない場合は T_c=25°C / unless otherwise specified)

項目 Item	記号 Symbol	条件 Conditions	品名 Type No.	D50XB80	単位 Unit	
保存温度 Storage Temperature	T _{stg}			-40~150	°C	
接合部温度 Operation Junction Temperature	T _j			150	°C	
せん頭逆電圧 Maximum Reverse Voltage	V _{RM}			800	V	
出力電流 Average Rectified Forward Current	I _O	50Hz 正弦波, 抵抗負荷 50Hz sine wave, Resistance load	フィン付き With heatsink	T _c = 95°C	50.0	A
			フィンなし Without heatsink	T _a = 26°C	4.6	
せん頭サージ順電流 Peak Surge Forward Current	I _{FSM}	50Hz 正弦波, 非繰り返し1サイクルせん頭値, 一素子当たりの規格値, T _j = 25°C 50Hz sine wave, Non-repetitive 1cycle peak value, per diode, T _j = 25°C		600	A	
電流二乗時間積 Current Squared Time	I ² t	1ms ≤ t < 10ms, 1素子当たりの規格値 per diode		1800	A ² s	
絶縁耐圧 Dielectric Strength	V _{dis}	一括端子・ケース間, AC 1分間印加 モールド部上面(端子と平行面)は除く Terminals to Case, AC 1 minute Except top (opposite side of the terminal side) of the mold case.		2.0	kV	
締め付けトルク Mounting Torque	TOR	(推奨値: 1.2 N・m) (Recommended torque: 1.2 N・m)		1.5	N・m	

● 電氣的・熱的特性 Electrical Characteristics (指定のない場合は T_c=25°C / unless otherwise specified)

順電圧 Forward Voltage	V _F	I _F = 25A, パルス測定, 1素子当たりの規格値 Pulse measurement, per diode	MAX 1.05	V
逆電流 Reverse Current	I _R	V _R = 800V, パルス測定, 1素子当たりの規格値 Pulse measurement, per diode	MAX 10	μA
熱抵抗 Thermal Resistance	θ _{jc}	接合部・ケース間 Junction to Case	MAX 0.5	°C/W
	θ _{ja}	接合部・周囲間 Junction to Ambient	MAX 16	

■特性図 CHARACTERISTIC DIAGRAMS

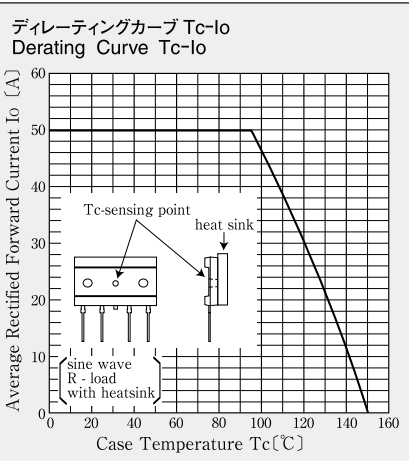
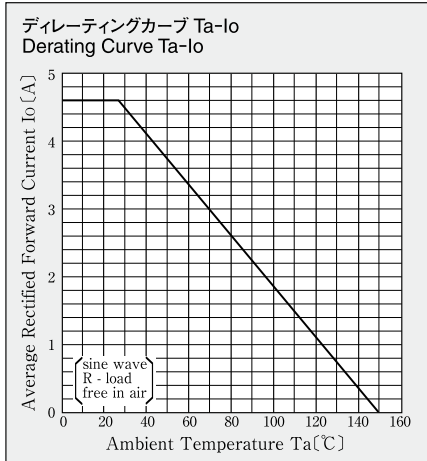
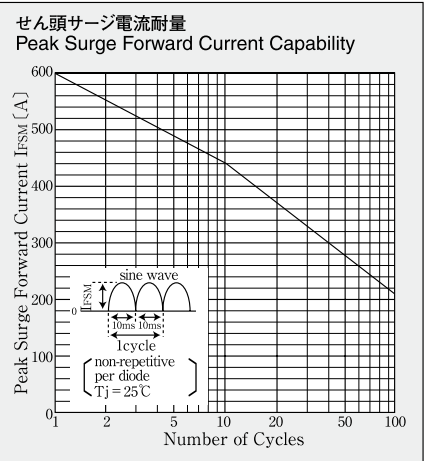
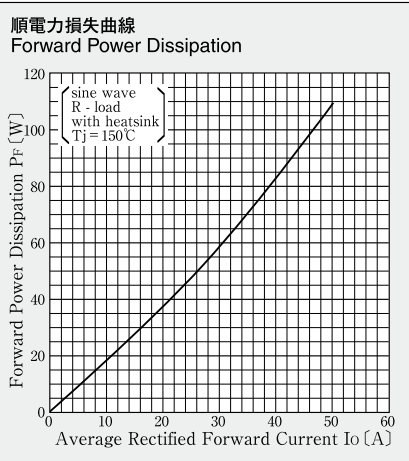
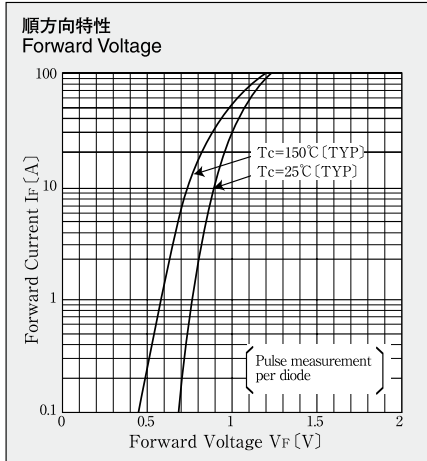

- * Sine wave は 50Hz で測定しています。
- * 50Hz sine wave is used for measurements.
- * 半導体製品の特性は一般的にバラツキを持っています。
Typical は統計的な実力を表しています。
- * Semiconductor products generally have characteristic variation.
Typical is a statistical average of the device's ability.