



Micro Commercial Components

Micro Commercial Components
 20736 Marilla Street Chatsworth
 CA 91311
 Phone: (818) 701-4933
 Fax: (818) 701-4939

PB605 THRU PB610

Features

- Glass Passivated chip
- Low Forward Voltage
- Any Mounting Position
- Silver Plated Copper Leads
- Surge Overload Rating Of 150 Amps
- UL Recognized File # E165989
- Case Material: Molded Plastic. UL Flammability Classificatio Rating 94-0 and MSL Rating 1
- Lead Free Finish/RoHS Compliant (NOTE 1)("P" Suffix designates RoHS Compliant. See ordering information)

Maximum Ratings

- Operating Temperature: -55°C to +125°C
- Storage Temperature: -55°C to +150°C

Microsemi Catalog Number	Device Marking	Maximum Recurrent Peak Reverse Voltage	Maximum RMS Voltage	Maximum DC Blocking Voltage
PB605	PB605	50V	35V	50V
PB61	PB61	100V	70V	100V
PB62	PB62	200V	140V	200V
PB64	PB64	400V	280V	400V
PB66	PB66	600V	420V	600V
PB68	PB68	800V	560V	800V
PB610	PB610	1000v	700V	1000v

Electrical Characteristics @ 25°C Unless Otherwise Specified

Average Forward Current	$I_{F(AV)}$	6.0A	$T_J = 50^\circ\text{C}$
Peak Forward Surge Current	I_{FSM}	150A	8.3ms, half sine
Maximum Forward Voltage Drop Per Element	V_F	1.10V	$I_{FM} = 3.0\text{A};$ $T_J = 25^\circ\text{C}$ (Note 2)
Maximum DC Reverse Current At Rated DC Blocking Voltage	I_R	10µA 1 mA	$T_J = 25^\circ\text{C}$ $T_J = 100^\circ\text{C}$

- Notes: 1. High Temperature Solder Exemption Applied, see EU Directive Annex Notes 7
 2. Pulse Test: Pulse Width 300µsec, Duty Cycle 1%

6 Amp Glass Passivated Rectifier 50 to 1000 Volts

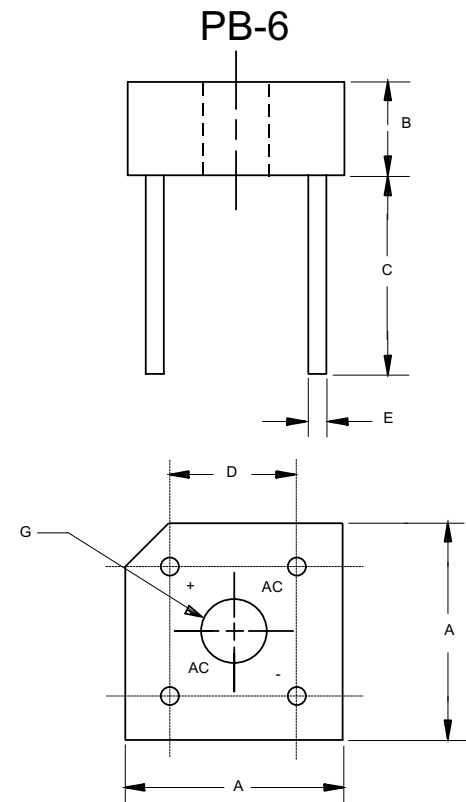

DIM	INCHES		MM		NOTE
	MIN	MAX	MIN	MAX	
A	.578	.618	14.69	15.71	2PL
B	.230	.270	5.84	6.86	
C	.750	---	19.10	---	
D	.405	.444	10.30	11.30	2PL
E	.038	.042	0.97	1.07	4PL/TYP
G	.145	---	3.70	---	∅

PB605 thru PB610

Figure 1
Typical Forward Characteristics

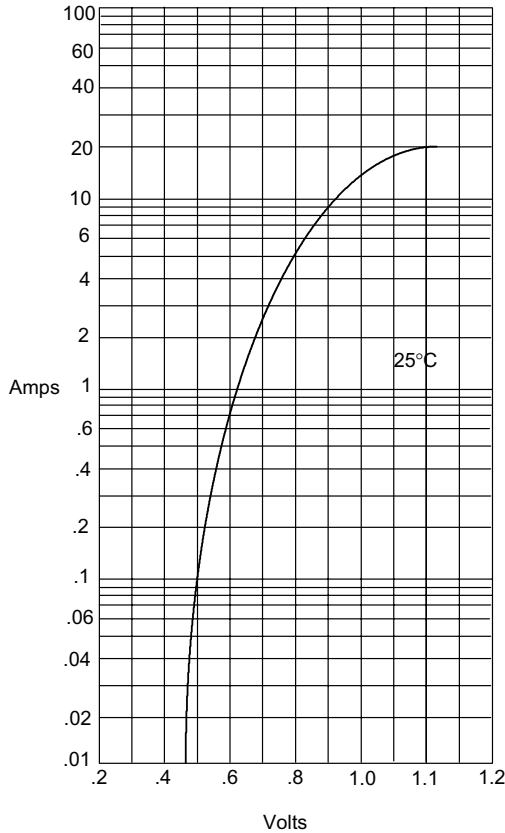

Instantaneous Forward Current - Amperes versus
Instantaneous Forward Voltage - Volts

Figure 2
Micro Commercial Components
Typical Reverse Characteristics

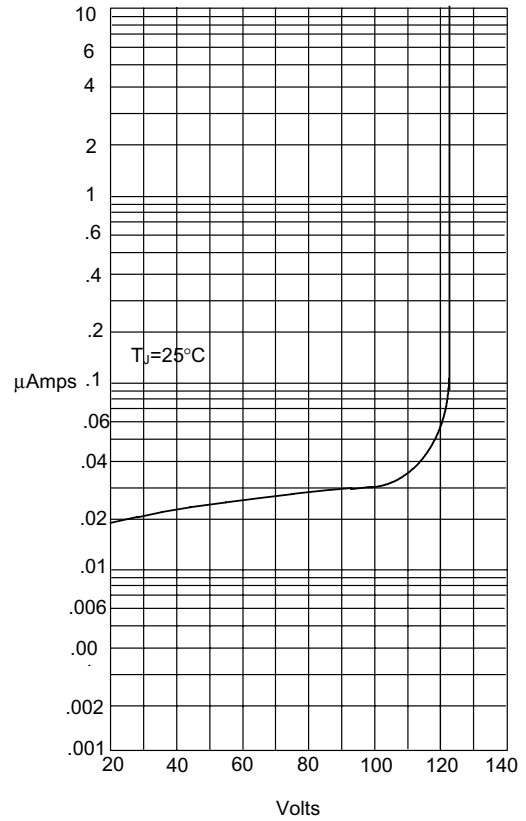

Instantaneous Reverse Leakage Current - MicroAmperes versus
Percent Of Rated Peak Reverse Voltage - Volts

Figure 3
Forward Derating Curve

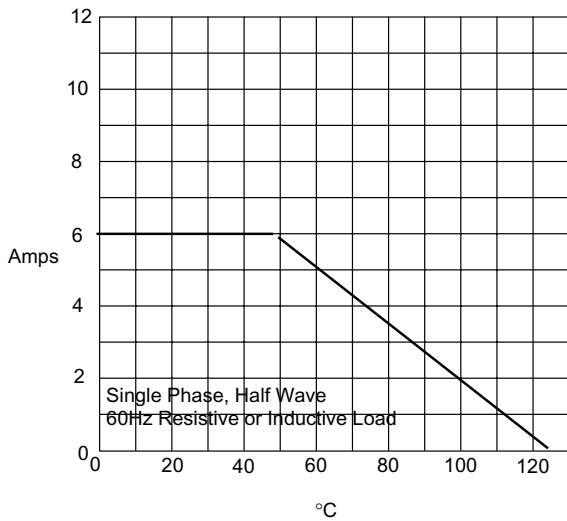

Average Forward Rectified Current - Amperes versus
Ambient Temperature - °C

Figure 4
Peak Forward Surge Current

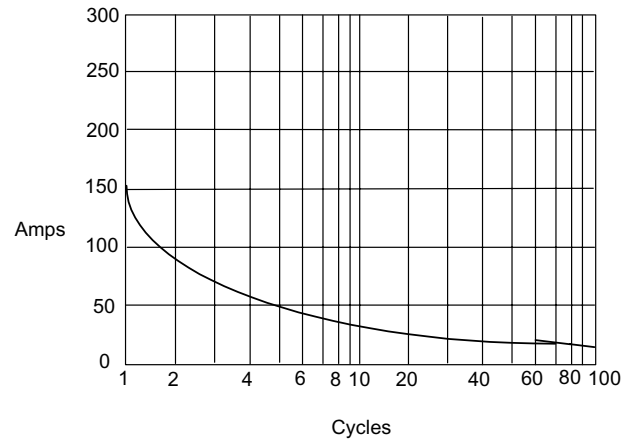

Peak Forward Surge Current - Amperes versus
Number Of Cycles At 60Hz - Cycles



Micro Commercial Components

Ordering Information

Device	Packing
(Part Number)-BP	Bulk;200pcs/Box

*****IMPORTANT NOTICE*****

Micro Commercial Components Corp. reserves the right to make changes without further notice to any product herein to make corrections, modifications, enhancements, improvements, or other changes. *Micro Commercial Components Corp.* does not assume any liability arising out of the application or use of any product described herein; neither does it convey any license under its patent rights, nor the rights of others. The user of products in such applications shall assume all risks of such use and will agree to hold *Micro Commercial Components Corp.* and all the companies whose products are represented on our website, harmless against all damages.

*****APPLICATIONS DISCLAIMER*****

Products offer by *Micro Commercial Components Corp.* are not intended for use in Medical, Aerospace or Military Applications.